



Networkforyou

Subscribe to our
You Tube Channel



Network for you



**Welcome
To
Network for you
Wireless**



Email us:
networkforyou4@gmail.com

1 of 33

WhatsApp Us : +966532984612



Communication: Transferring of data from one point to another point is known as communication.

- If device is using wired to connect other device then it is known as wired communication.
- If device is not using wired to connect other devices then it is known as wireless Communication.
- A wired network uses cables to connect devices, such as laptop or desktop computers, to the Internet or another network.
- The most common wired networks use cables connected at one end to an Ethernet port on the network router and at the other end to a computer or other device.

Wired network:

- In computing terminology, the term "wired" is used to differentiate between wireless connections and those that involve cables.
- A wired setup uses physical cables to transfer data between different devices and computer systems.
- The cables can be copper wire, twisted pair or fiber optic.
- Wired network is used to carry different forms of electrical signals from one end to the other.
- Most wired networks use Ethernet cables to transfer data between connected PCs.
- Ethernet works or operates in a narrow range and it is little bit difficult to configure as compared to wireless networking technologies.

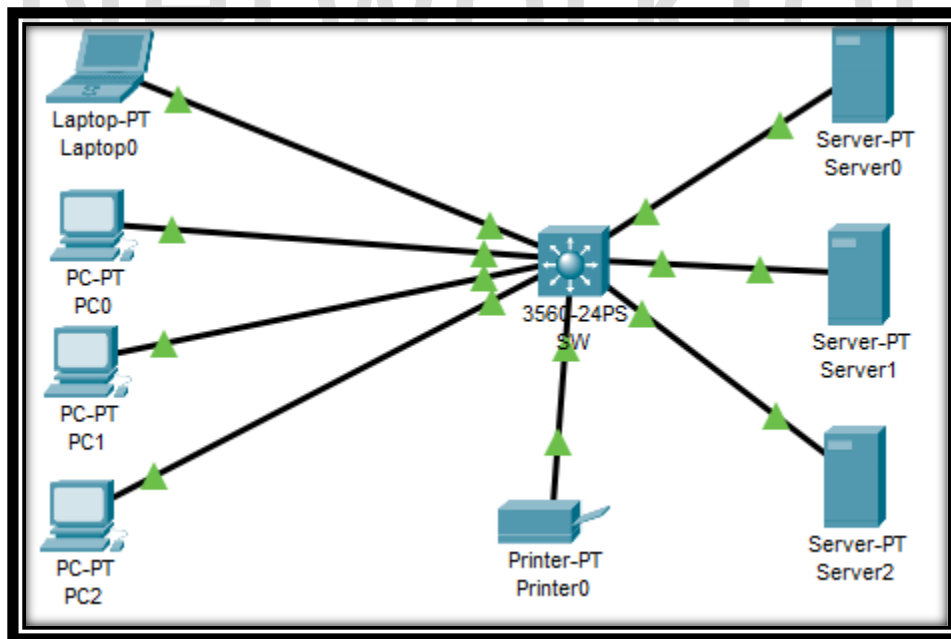

Email us:
networkforyou4@gmail.com

2 of 33

WhatsApp Us : +966532984612



Wireless Network:

- Wi-Fi stands for Wireless Fidelity.
- WIFI services are defined in the IEEE 802.11 standard.
- IEEE stands for Institute of Electrical and Electronics Engineers.
- Wireless network refers to the use of infrared or radio frequency signals to share information and resources between devices.
- Wireless technologies are designed to reduce the time and different type of obstacles created by the cables.
- Wireless network does not use wires for data or voice communication; it uses radio frequency waves.
- Many types of wireless devices are available today; for example, cellular mobile, handheld PCs, satellite receivers, laptop, wireless sensors etc.
- Easy to setup.
- Fewer Configurations (One person could do it).

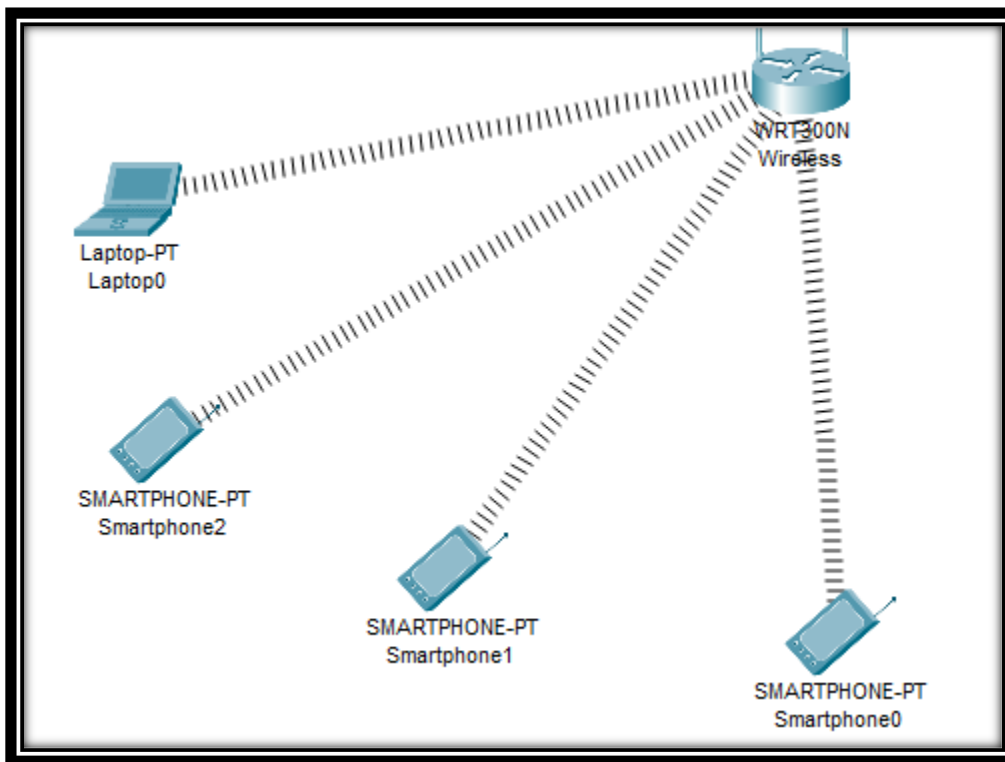

Email us:
networkforyou4@gmail.com

3 of 33

WhatsApp Us : +966532984612



Access Point:

- A device that allows wireless devices to connect to a wired network using Wi-Fi.
- Access Point is a device that creates wireless local area network, or Wireless LAN.
- Access Point is a device creates Wireless LAN usually in an office or large building.
- AP is the device that allows multiple wireless devices to connect with each other.
- AP connects multiple wireless devices together in single or multiple wireless networks.
- AP is a networking device that is used to form wireless local area network in home.
- An access point connects to a wired router, switch, or hub via an Ethernet cable.
- AP is hardware device used to connect computer, laptops and mobile with each other.
- Wireless networks are suitable for those places where cables are difficult to install.
- An access point can also be used to extend the wired network to the wireless devices.
- The AP converts the wireless frequency subject into digital signals and then vice versa.



AP Categories:

Autonomous APs:

- These are standalone devices configured using a command line interface or a GUI.
- Autonomous APs are useful in situations where only couple of APs is required in office.
- Such as home router is autonomous AP because entire configuration resides on device.
- If wireless demands increase, more Access Points (APs) would be required to deploy.
- Each AP operates independent of other APs & each AP require manual configuration.
- Each AP operates independent of other APs & each AP requires manual management.
- Autonomous Access Points is Standalone mode and Management address for remote.

Controller-Based APs:

- These devices require no initial configuration and are often called lightweight APs (LAPs).
- LAPs use Lightweight Access Point Protocol to communicate with WLAN controller (WLC).
- Controller-based APs are useful in situations where many APs are required in the network.

Email us:
networkforyou4@gmail.com

4 of 33

WhatsApp Us : +966532984612

- As more APs are added, each AP is automatically configured and managed by the WLC.

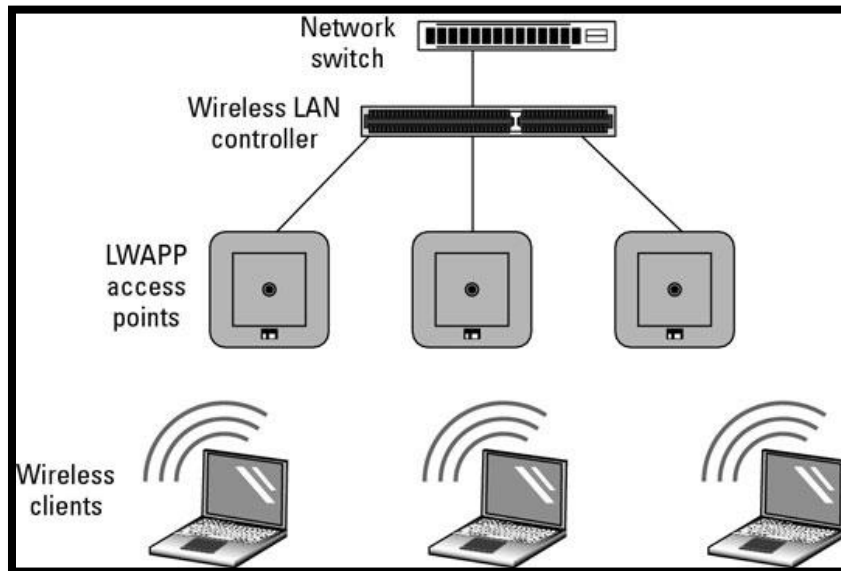

Antennas:

- In Simple words we can say Antenna is metallic wire use to transmit or receive RF signal.
- Wireless routers have different types of antennas; some routers have antennas built in.
- Sometimes the Wi-Fi routers will have a choice of antenna you can attach to the router.
- Antennas come in many sizes & shapes, each with its own gain value & intended purpose.
- There are many specific types of antennas, but two basic types are used most of time.
- Most business class APs requires external antennas to make them fully functioning units.

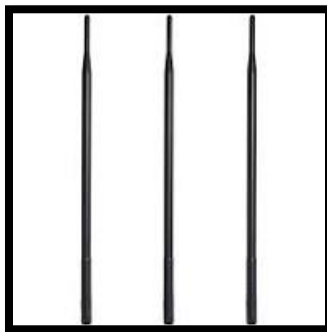



Omnidirectional Antennas:

- An omnidirectional antenna sends a signal out equally in all directions around it.
- Using omnidirectional antennas has benefit of creating connections in any direction.
- You don't have to do as much planning to connect with multiple neighbors or buildings.
- Omnidirectional Antenna If there is enough signal between nodes, they should connect.
- All-direction strength of antennas comes with drawback of transmitting weaker signal.
- Since signal is going in all directions, it spreads out & gets weaker with distance very fast.
- If the nodes or clients, PC, Laptop or end point are far away, they may not connect well.
- Provide 360-degree coverage & are ideal in houses, office, conference rooms & outside.

Directional Antennas:

- Next type of antenna is known as directional. It sends out a signal in a more focused way.
- This Type of Antennas, Directional antennas focus the radio signal in a given direction.
- Using directional antennas has benefit of increasing distance signal travel in one direction.
- Power that would be sent out in all directions with omnidirectional nodes is now focused.
- This type of Directional antennas is commonly used in point-to-point configurations and connecting two distant buildings.

Examples of directional: Wi-Fi antennas include Yagi and parabolic dish antennas.

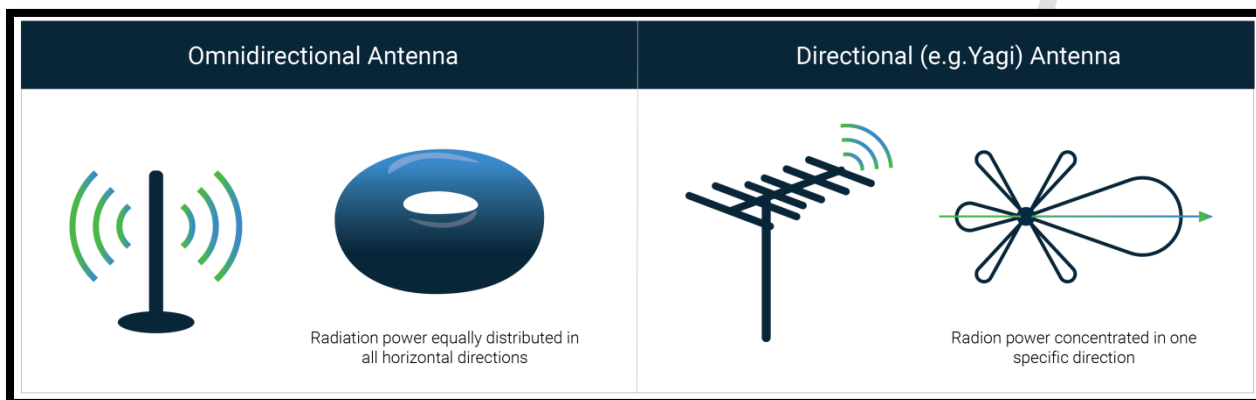

Email us:
networkforyou4@gmail.com

6 of 33

WhatsApp Us : +966532984612



There are basically three different types of wireless networks – WAN, LAN and PAN:

Wireless Wide Area Networks (WWAN):

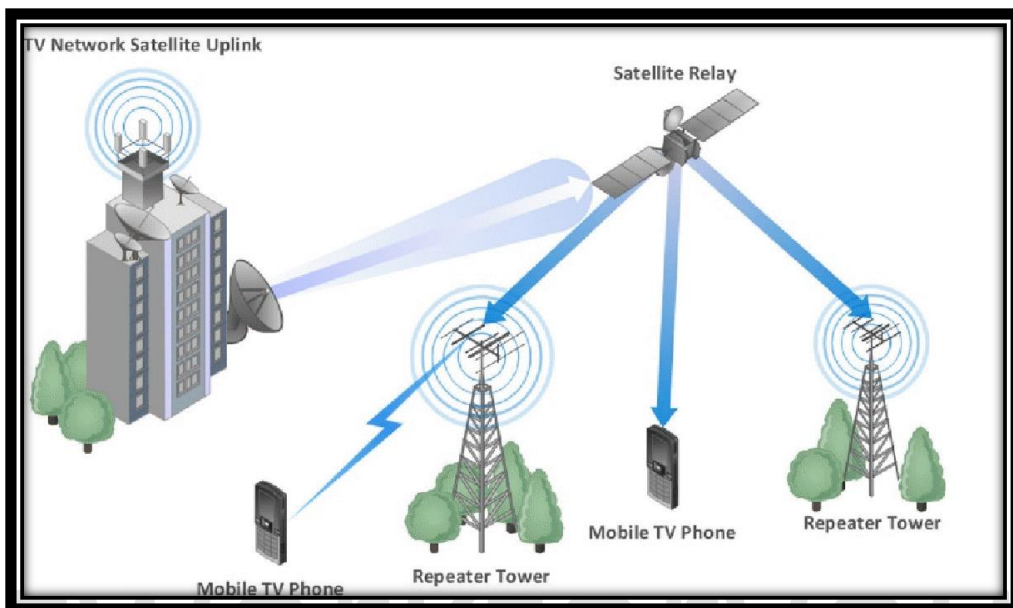

- Interconnecting devices over large areas, such as cities or countries (Very large distance coverage) like multiple satellite systems or antenna sites looked after by an ISP.
- Mobile telecommunication cellular network technologies such as 2G, 3G, 4G LTE and 5G to transfer data.

Wireless Local Area Network (WLAN):

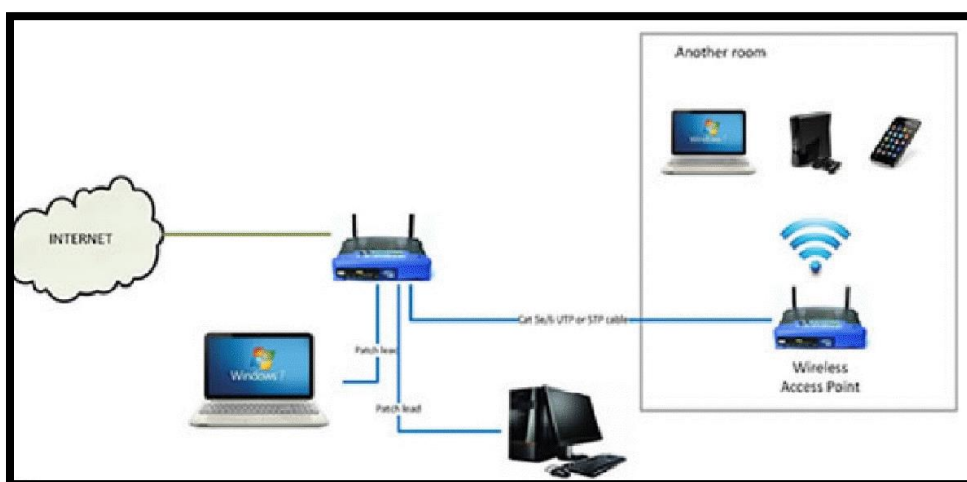

Email us:
networkforyou4@gmail.com

WhatsApp Us : +966532984612



- **WLAN are wireless networks that use radio waves.**
- The backbone network usually **uses cables**, with one or more wireless access points connecting the wireless users to the wired network.
- The range of a WLAN can be anywhere from a single room to an entire campus.
- Devices within 100m of a wireless access point.

Wireless Personal Area Network (WPAN):

- WPANs are short-range networks **that use Bluetooth technology.**
- Devices are within 10 meters of each other.
- Bluetooth is often used.
- They are commonly used to interconnect compatible devices near a central location, such as a desk.
- A WPAN has a typical range of about 30 feet.

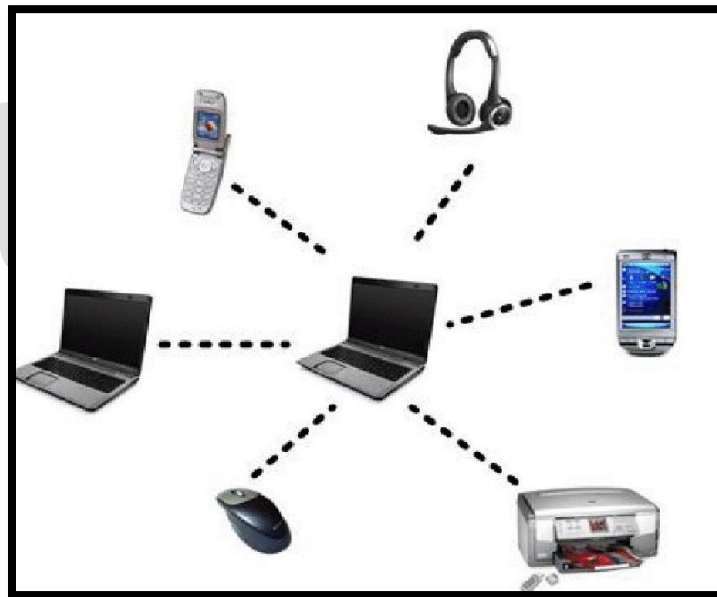

Wireless communication usually involves a data exchange between two devices.

- A wireless LAN goes even further; many devices can participate in sharing the medium for data Exchanges.

Email us:
networkforyou4@gmail.com

8 of 33

WhatsApp Us : +966532984612



- Wireless LANs must transmit a signal over radio frequencies (RF) to move data from one device to another.
- Transmitters and receivers can be fixed in consistent locations, or they can be mobile and free to move around.
- Wireless devices must adhere to a common standard (IEEE 802.11).
- Wireless coverage must exist in the area where devices are expected to use it.

Wireless LAN – Devices:

- Wireless clients with Wireless NIC.
- Laptops, IP Phones, Smartphones and Printer.
- Access Points.
- Wireless LAN Controller (WLC).

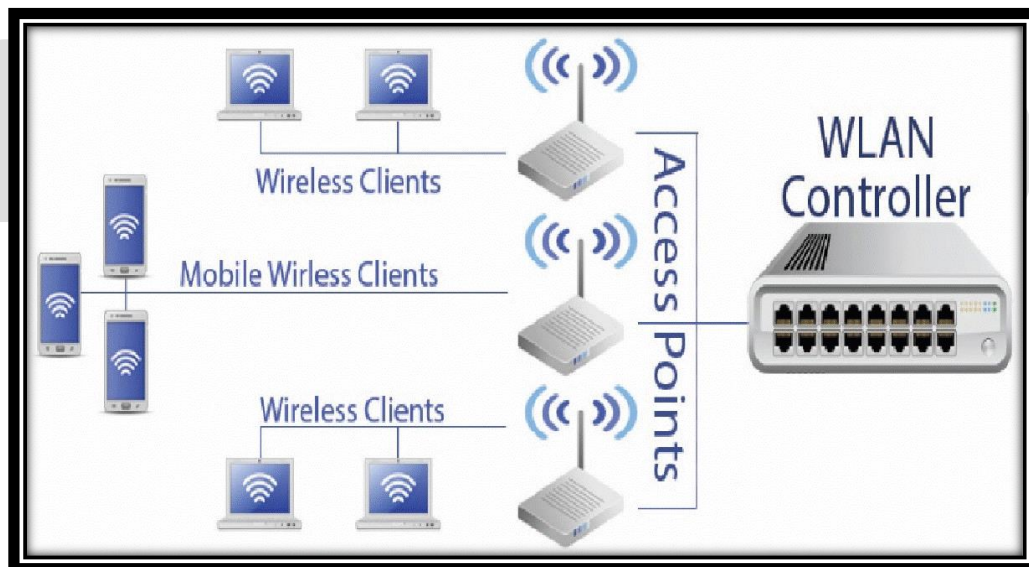

Wireless Access Point (WAP):

- Provides centralized location to connect devices with in the LAN.
- Without wire (it is using RF Signals).
- Allows other WIFI devices to connect to a wired network.
- Provide wireless Internet in Public palaces, like shops, Airport and coffee shops.

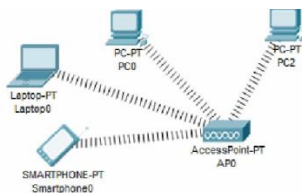

Wireless LAN Controllers (WLC):

- Provides Centralized management of all access points in the networks.
- Make it easier to manager large wireless scale deployments.

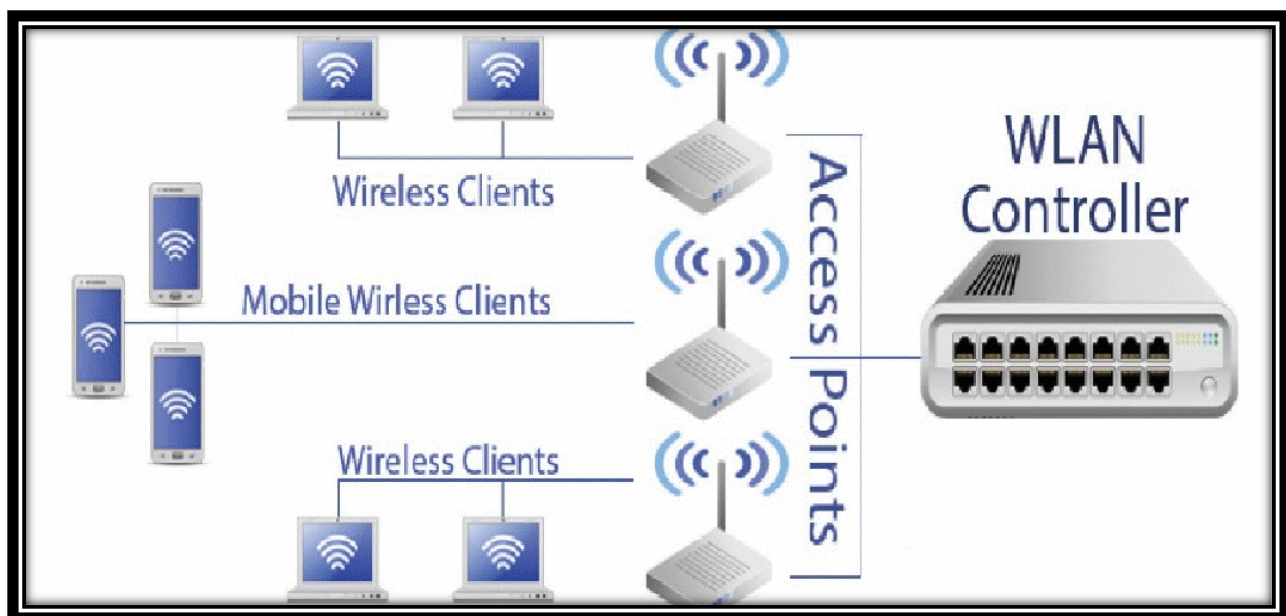

Ad Hoc Networks:

- Two or more wireless stations communicate directly with each other.
- IBSS Independent Basic Service Set.
- Ad hoc networks rely on multi-hop transmissions among the nodes in the same channel.
- Nodes communicate with each other through the intermediate nodes.
- So, the efficient performance and availability of each node is important in ad hoc network environment.
- Ad Hoc also called computer to computer or peer mode.

Email us:
networkforyou4@gmail.com

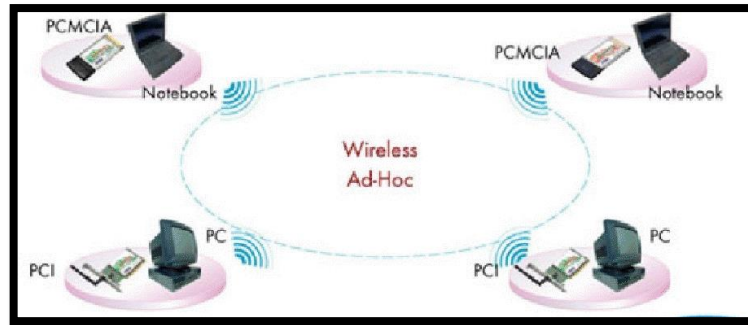
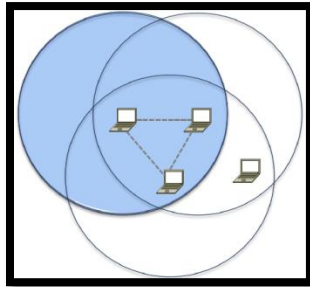

Infrastructure Mode:

- Stations communicate via a Wireless Access Point (AP).
- This can provide access to a wired network.
- Requires a central access point that all devices connect to.
- Devices on the network all communicate through a Access Point (AP).
- Like Laptop or smart mobile send packet to the access point and it send to the other devices.
- Most wireless networks function in infrastructure mode.
- Access points acts as a bridge to other wireless or wired network.

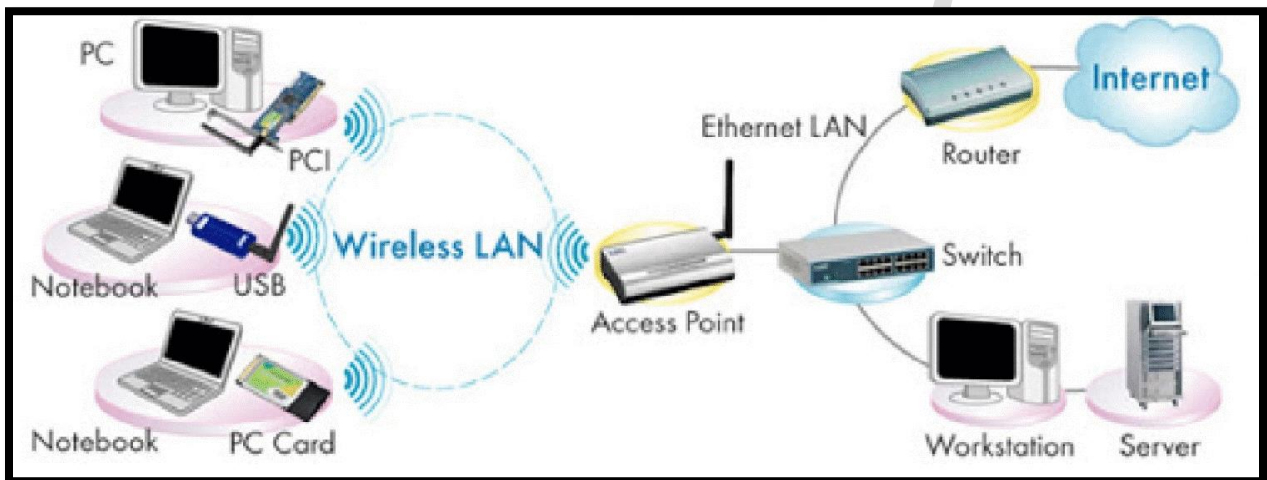

Email us:
networkforyou4@gmail.com

WhatsApp Us : +966532984612

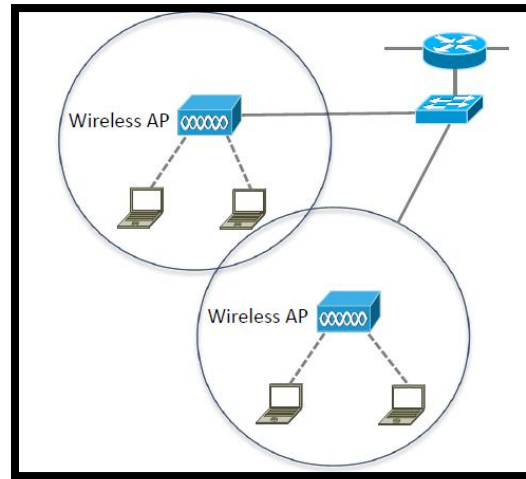
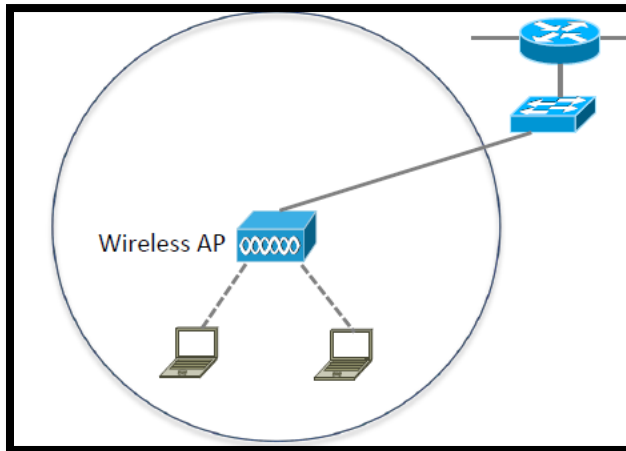

- **Multiple Access Points can be deployed to provide the required coverage area**
- **Wireless stations work in either Ad-HOC or Infrastructure Mode they cannot operate in both at the same time.**
- **BSSID is the MAC address of the AP's radio for that service set. SSID is the service set identifier or network name for the basic service set(BSS). ESSID is the same as the SSID but is used across multiple access points as part of the same WLAN.**

Wireless LAN terminology:

- SSID
- Basic Service Set (BSS)
- Basic Service Area (BSA)
- Distribution system
- Extended Service Set (ESS)
- 802.11

SSID (Service Set Identifier):

- SSID stand for Service Set Identifier.
- SSID is the name for a WIFI network.
- Unique ID used for naming wireless networks.
- Client devices use this name to identify and join wireless networks.
- A single Access Point can support multiple SSIDs.
- Different SSIDs can have different security settings and be mapped to different VLANs.

Email us:
networkforyou4@gmail.com

12 of 33

WhatsApp Us : +966532984612

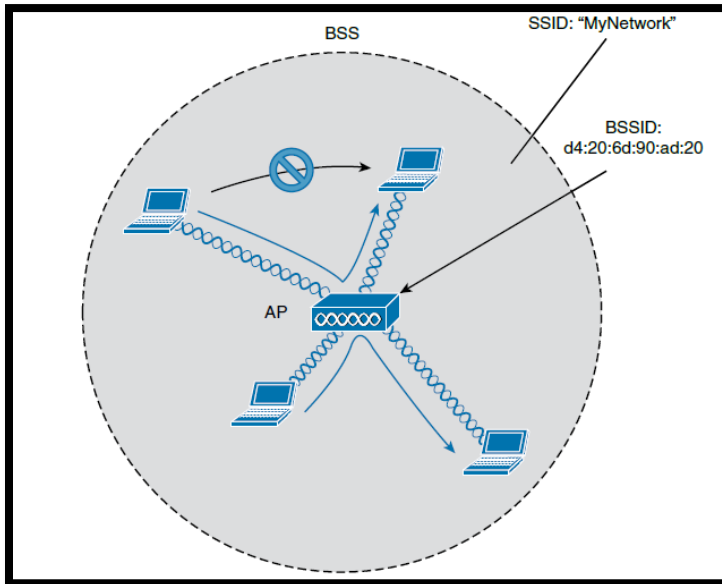

BSS (Basic Service Set):

- BSS stand for Basic Service Set.
- With a Basic Service Set (BSS), wireless clients connect to a wireless network through an AP.
- The idea behind a BSS is that the AP is responsible for the wireless network. A BSS we use for most wireless networks
- Each wireless client advertises its capabilities to the AP, and the AP grants or denies permission to join the network.
- The BSS uses a single channel for all communication.
- The AP and its wireless clients use the same channel to transmit and receive.

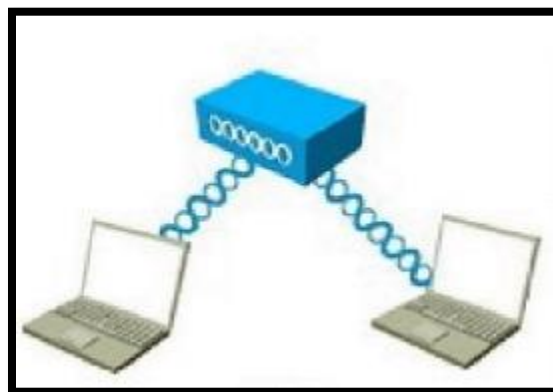

Email us:
networkforyou4@gmail.com

13 of 33

WhatsApp Us : +966532984612



BSA (Basic Service Area):

- BSS stand for Basic Service Area.
- The BSA is the Wireless Coverage area of an Access Point.
- Also known as a wireless cell.

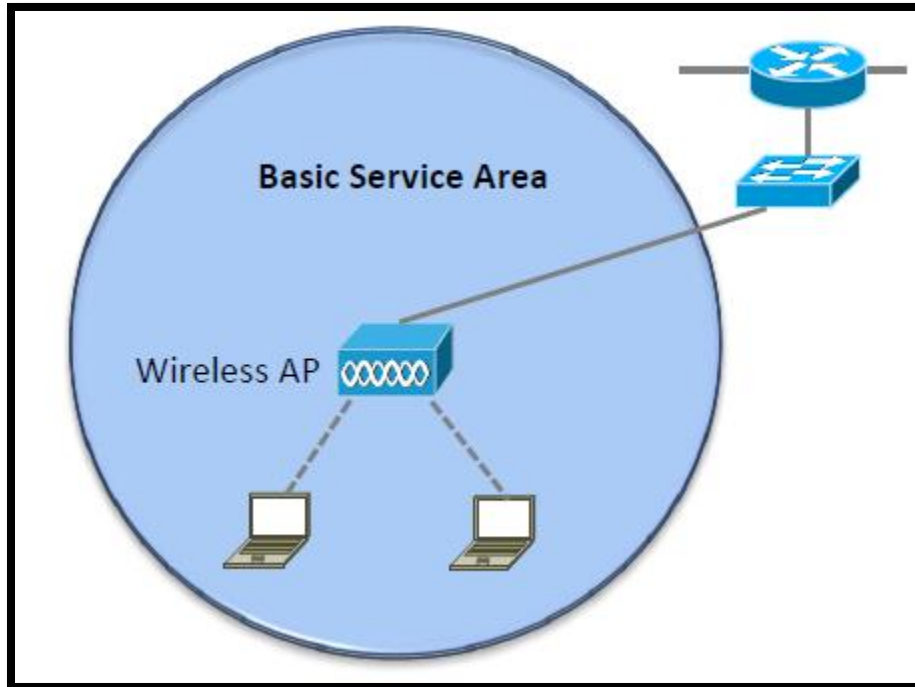

Distribution System:

- Notice that a BSS involves a single AP and no explicit connection into a regular Ethernet network.
- In that setting, the AP and its associated clients make up a standalone network.
- But the AP's role at the center of the BSS does not just stop with managing the BSS; sooner or later, Wireless clients will need to communicate with other devices that are not members of the BSS.
- Fortunately, an AP can also uplink into an Ethernet network because it has both wireless and wired capabilities.
- The 802.11 standard refers to the upstream wired Ethernet as the distribution system (DS) for the wireless BSS, as shown below.

Email us:
networkforyou4@gmail.com

14 of 33

WhatsApp Us : +966532984612

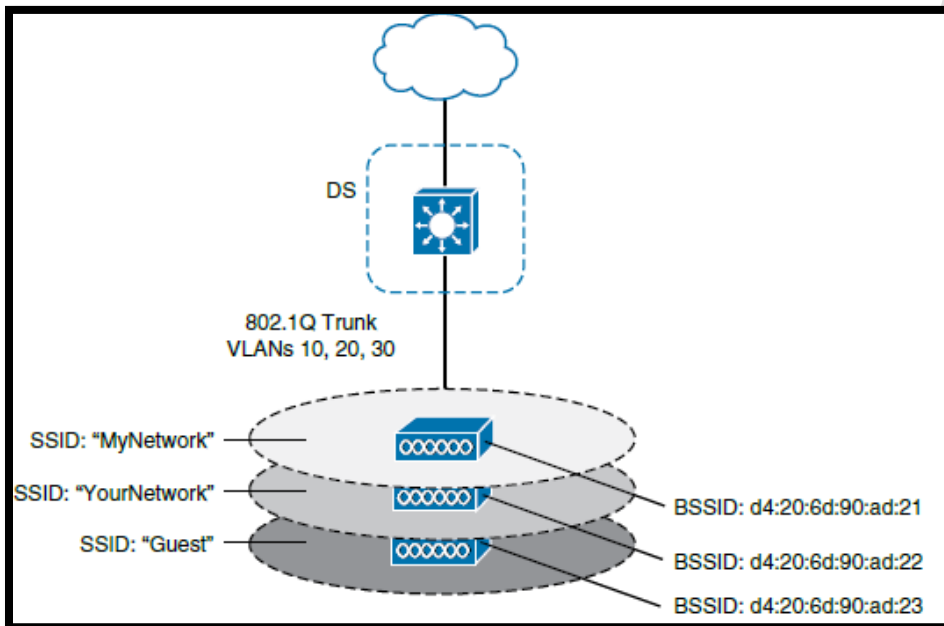
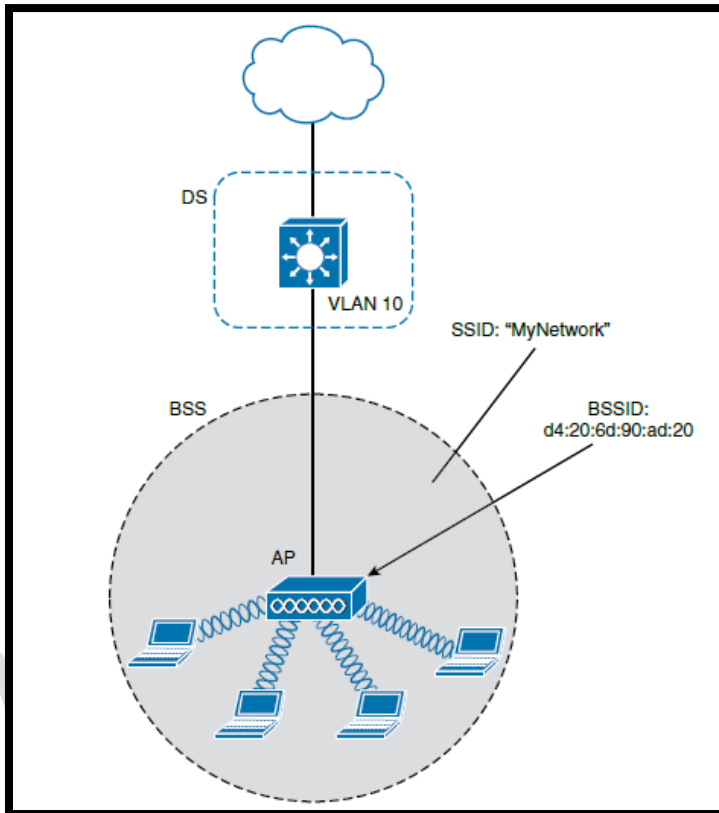

Email us:
networkforyou4@gmail.com

WhatsApp Us : +966532984612



ESS (Extended Service Set):

- ESS Stand for Extended Service Set.
- Normally one Access Point cannot cover the entire area where clients might be located so we need to use Extended Service Set.
- Example you need to have wireless Coverage throughout an entire floor of Office or Hotel or Hospital or any large building.
- Simply need to add more Access points to coverage large area.

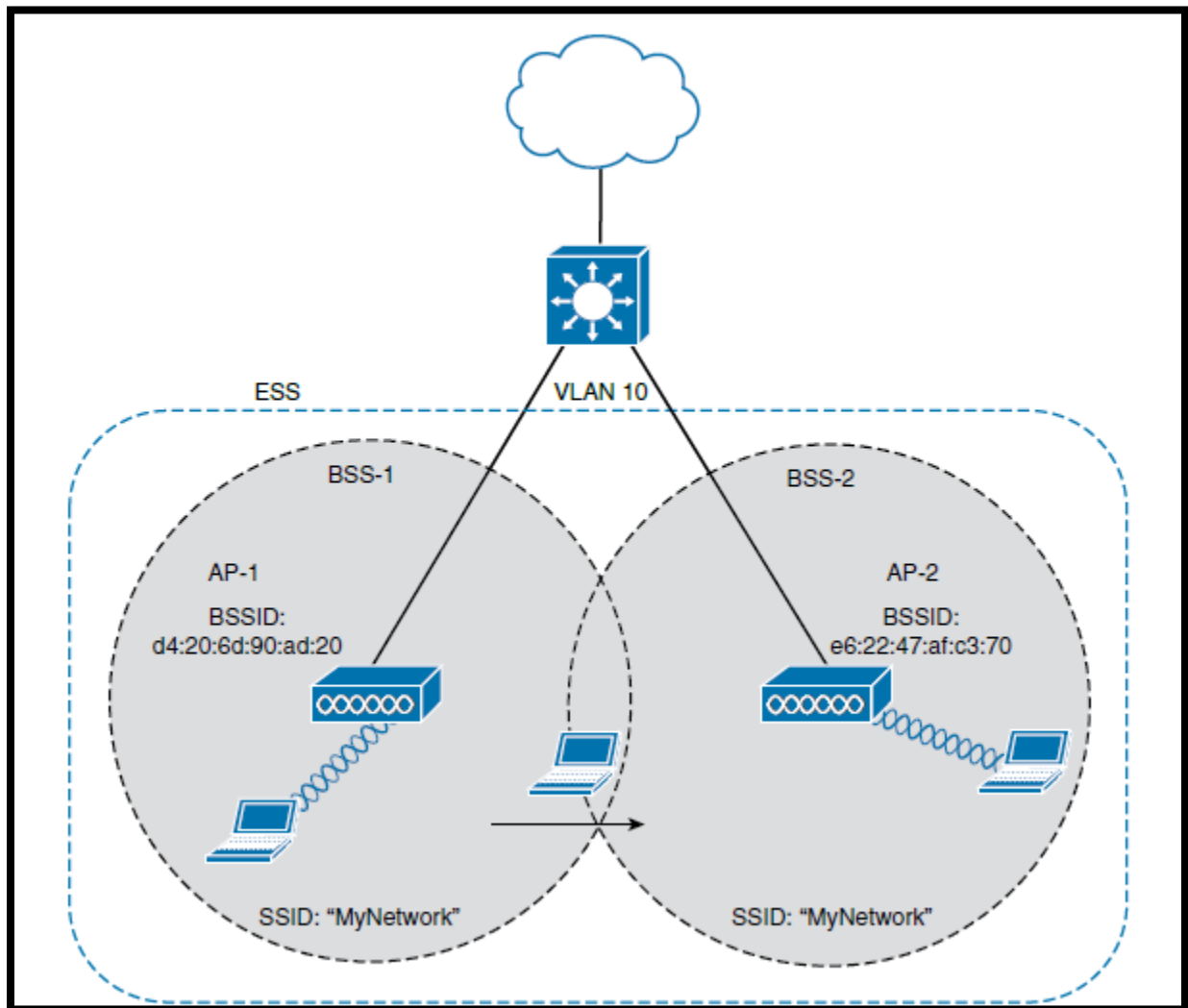

Email us:
networkforyou4@gmail.com

16 of 33

WhatsApp Us : +966532984612



RF Overview:

- To send data across a wired link, an electrical signal is applied at one end and carried to the other end.
- The wire itself is continuous and conductive, so the signal can propagate rather easily.
- A wireless link has no physical strands of anything to carry the signal along. How, then, can an electrical signal be sent across the air, or free space?
- Consider a simple analogy of two people standing far apart. One person wants to signal something to the other.
- They are connected by a long and somewhat loose rope; the rope represents free space.
- The sender at one end decides to lift his end of the rope high and hold it there so that the other end of the rope will also rise and notify the partner.
- After all, if the rope were a wire, he knows that he could apply a steady voltage at one end of the wire and it would appear at the other end.
- As showing below picture shows the end result; the rope falls back down after a tiny distance, and the receiver never notices a change.

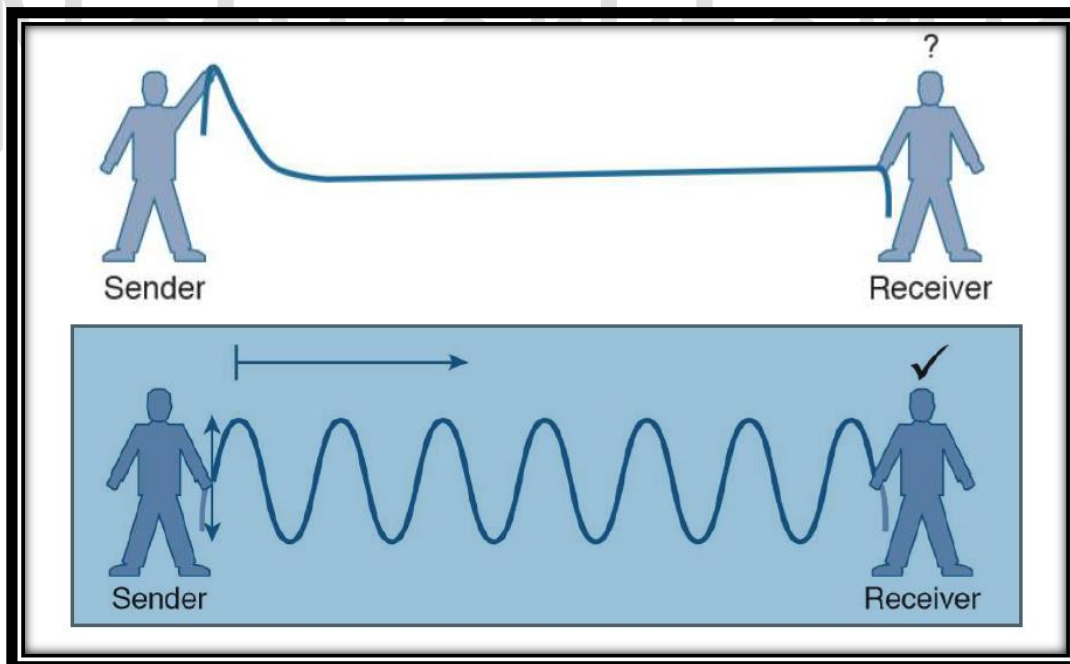

- The sender tries a different strategy. He cannot push the rope, but when he begins to wave it up and down in a steady, regular motion, a curious thing happens.
- A continuous wave pattern appears along the entire length of the rope, as shown in above picture.

Email us:
networkforyou4@gmail.com

17 of 33

WhatsApp Us : +966532984612



- In fact, the waves (each representing one up and down cycle of the sender's arm) actually travel from the sender to the receiver.
- In free space, a similar principle occurs. The sender (a transmitter) can send an alternating current into a section of wire (an antenna), which sets up moving electric and magnetic fields that propagate out and away as traveling waves.
- The electric and magnetic fields travel along together and are always at right angles to each other, as shown in below picture.
- The signal must keep changing, or alternating, by cycling up and down, to keep the electric and magnetic fields cycling and pushing ever outward.

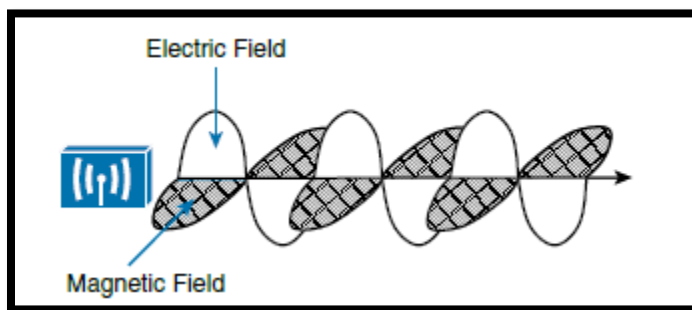

- Electromagnetic waves do not travel in a straight line. Instead, they travel by expanding in all directions away from the antenna.
- To get a visual image, think of dropping a pebble into a pond when the surface is still. Where it drops in, the pebble sets the water's surface into a cyclic motion.
- The waves that result begin small and expand outward, only to be replaced by new waves.
- In free space, the electromagnetic waves expand outward in all three dimensions.





Receivers and Transmitters:

- In Wireless Network when a device sends out a wireless signal, it is called a transmitter.
- When another device picks up wireless signal & understands information called receiver.

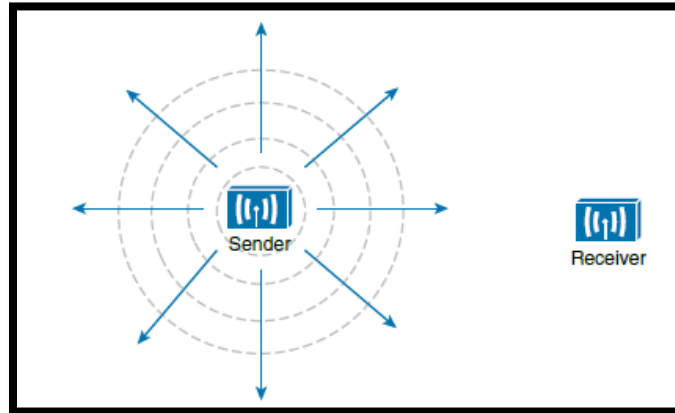

Frequency:

- Wireless signals occupy spectrum/wide range, of frequencies: rate at which signal vibrates.
- If signal vibrates slowly, it has low frequency, if vibrates very quickly, it has high frequency.
- Frequency is measured in Hertz, which is count of how quickly signal changes every second.
- Higher frequencies give higher data rates, higher frequency more waves in given time cycle.
- The Wireless technology uses the unlicensed radio spectrum/range to send & receive data.
- Unlicensed spectrum is accessible to anyone who has wireless router & wireless technology.
- Frequency is number of times signal makes one complete up and down cycle in 1 second.

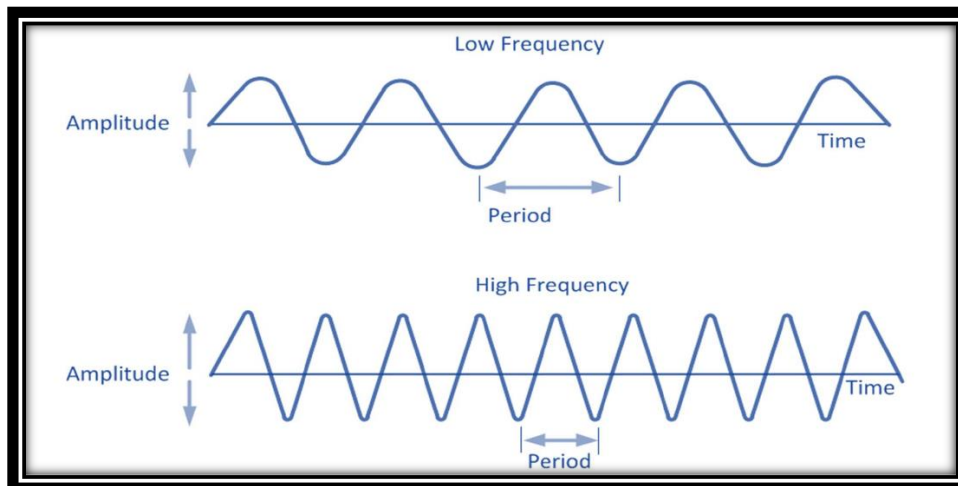

Email us:
networkforyou4@gmail.com

19 of 33

WhatsApp Us : +966532984612



Radio Frequencies:

- All wireless devices operate in the radio waves range of the electromagnetic spectrum.
- The Wireless LAN networks operate in the **2.4 GHz frequency band and the 5 GHz band**.
- WLAN devices have transmitters & receivers tuned to specific frequencies of waves range.
- Specifically, the following frequency bands are allocated to the 802.11 wireless LANs.
- Wireless LAN 2.4 GHz (UHF) - 802.11b/g/n/ax and WLAN 5 GHz (SHF) - 802.11a/n/ac/ax.
- The strength of an Radio Frequency signal is usually measured by its power, in watts(W).

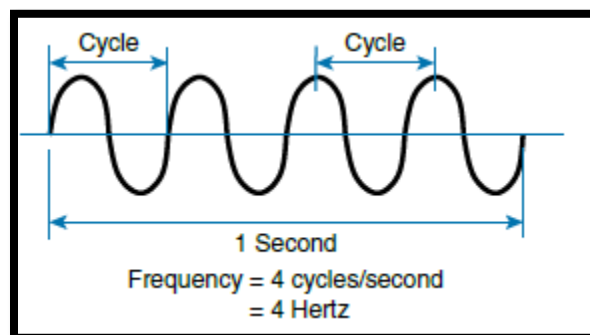
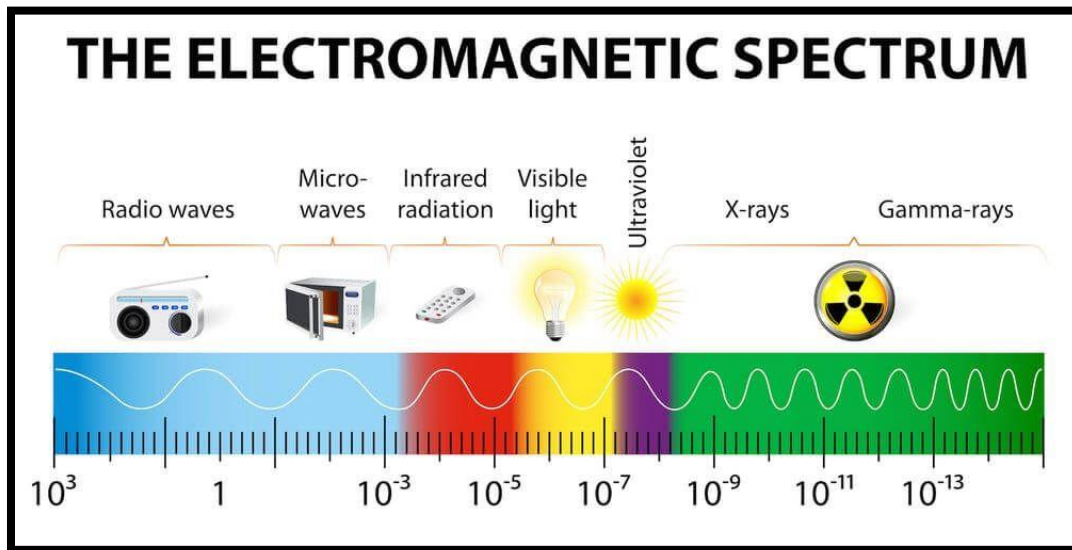

Terminologies:

Cycle:

- Cycle can begin signal rises from center line, falls through center line & rises again.
- Cycle can be measured from the center of one peak to the center of the next peak.

Email us:
networkforyou4@gmail.com

20 of 33

WhatsApp Us : +966532984612



- In above image, during that 1 second, signal progressed through four complete cycles.

Hertz:

- Hertz is most commonly used frequency unit & is nothing than one cycle per second.

Amplitude:

- Amplitude the height from the top peak to the bottom peak of the signal's waveform.
- It is power or intensity of signal, the frequency is how often the signal repeated itself.
- Higher the amplitude it will produce the higher range, lower amplitude lower range.

Wavelength:

- In wavelength they are the crest which is the high point, the trough which is low point.
- The wavelength is the distance from one crest or higher point, or trough, to another.

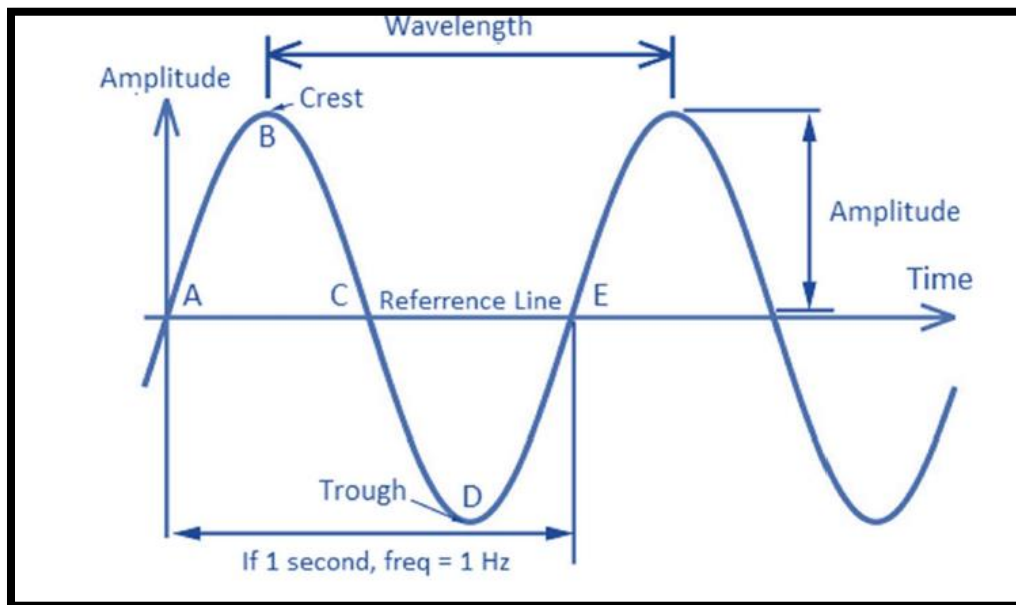



Frequency Unit Names:

Unit	Abbreviation	Meaning
Hertz	Hz	Cycles per second
Kilohertz	kHz	1000 Hz
Megahertz	MHz	1,000,000 Hz
Gigahertz	GHz	1,000,000,000 Hz

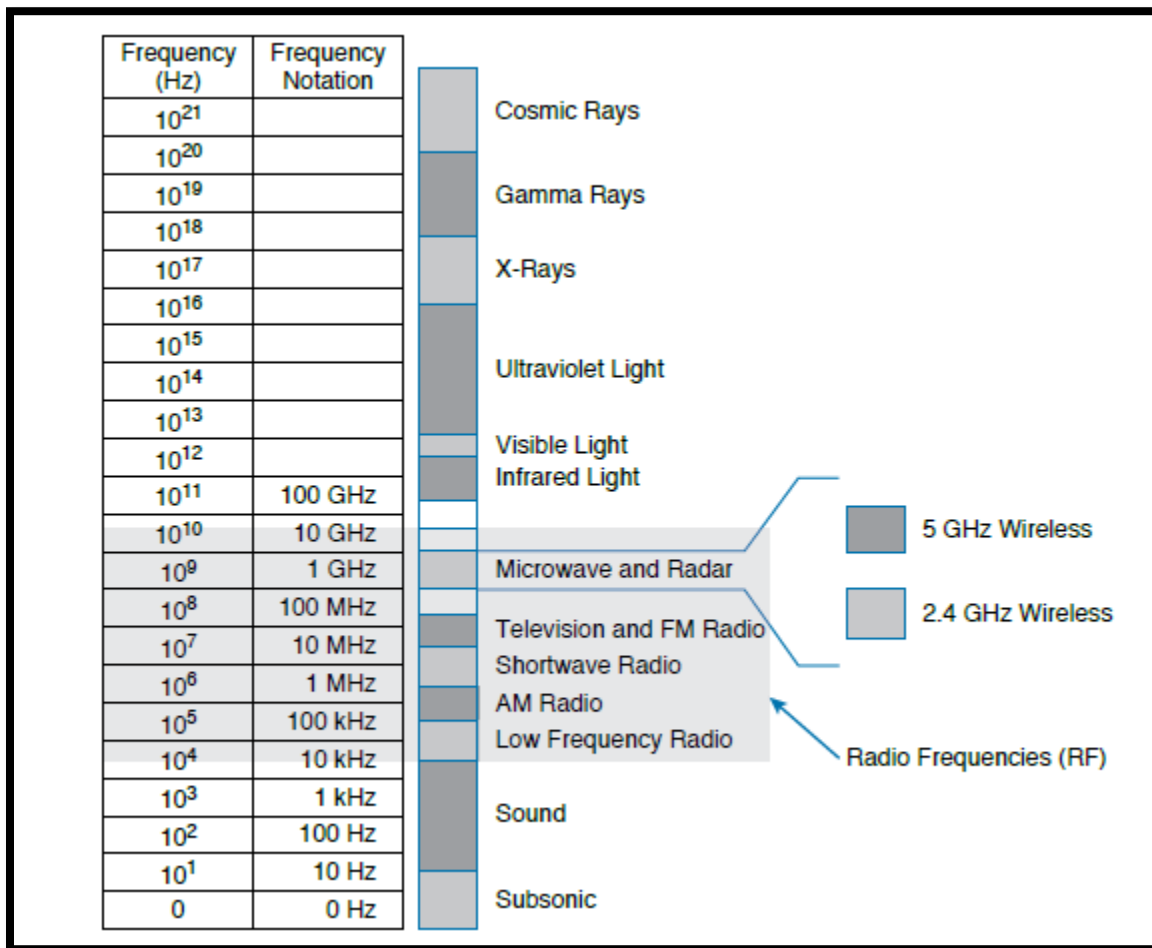

Email us:
networkforyou4@gmail.com

WhatsApp Us : +966532984612



Design Home Router:

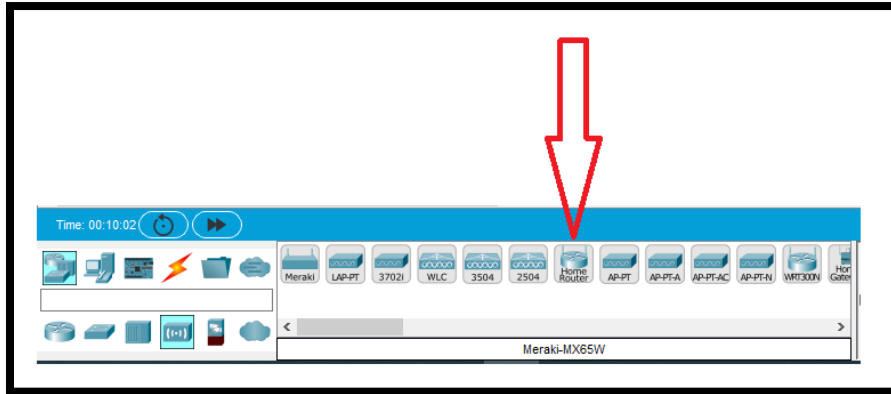

Take this Home Router

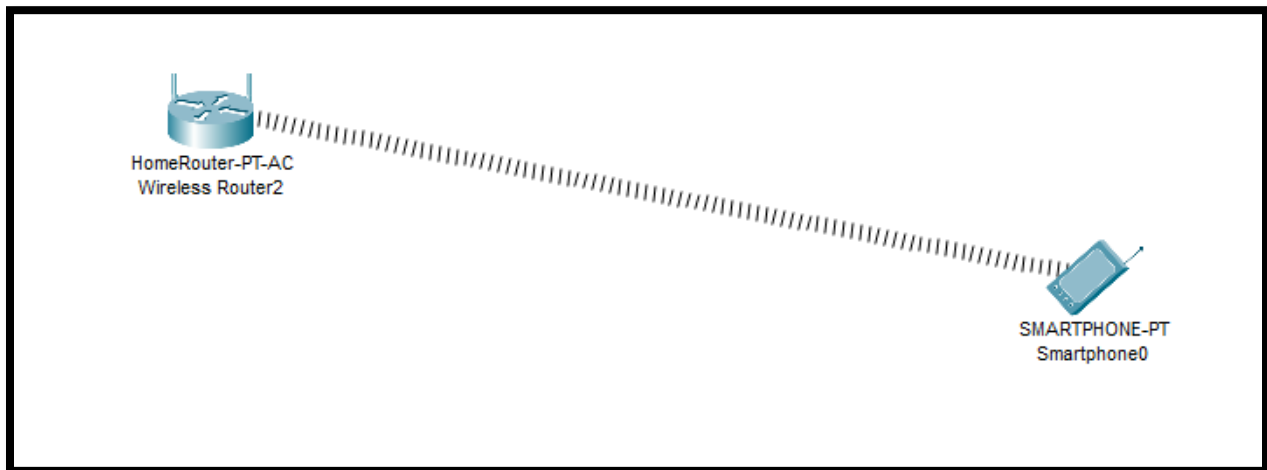

- We need to set Network SSID we can set any name as given below.
- We have three Network SSID we can set all three as given below.
- Then we need to assign password as given below screen short.

Email us:
networkforyou4@gmail.com

23 of 33

WhatsApp Us : +966532984612

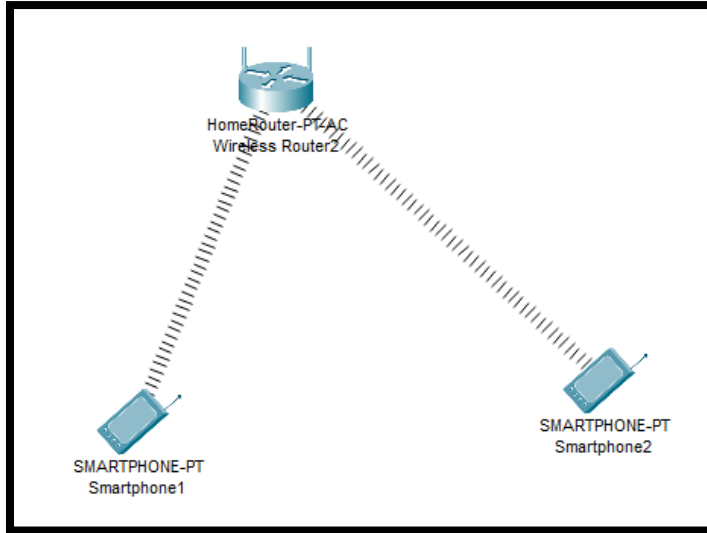

```
Smartphone1
Physical  Config  Desktop  Programming  Attributes
Command Prompt
Packet Tracer PC Command Line 1.0
C:\>ping 192.168.0.102

Pinging 192.168.0.102 with 32 bytes of data:

Reply from 192.168.0.102: bytes=32 time=28ms TTL=128
Reply from 192.168.0.102: bytes=32 time=36ms TTL=128
Reply from 192.168.0.102: bytes=32 time=23ms TTL=128
Reply from 192.168.0.102: bytes=32 time=5ms TTL=128

Ping statistics for 192.168.0.102:
    Packets: Sent = 4, Received = 4, Lost = 0 (0% loss),
    Approximate round trip times in milli-seconds:
        Minimum = 5ms, Maximum = 36ms, Average = 23ms

C:\>ipconfig

Wireless0 Connection:(default port)

    Connection-specific DNS Suffix...:
    Link-local IPv6 Address.....: FE80::290:CFF:FE7B:5CED
    IPv6 Address.....: ::
    IPv4 Address.....: 192.168.0.101
    Subnet Mask.....: 255.255.255.0
    Default Gateway.....: ::
                                     192.168.0.1

3G/4G Cell1 Connection:

    Connection-specific DNS Suffix...:
    Link-local IPv6 Address.....: FE80::201:43FF:FED0:7A9D
    IPv6 Address.....: ::
    Autoconfiguration IPv4 Address..: 169.254.122.157
    Subnet Mask.....: 255.255.0.0
    Default Gateway.....: ::
                                     0.0.0.0
```

Email us:
networkforyou4@gmail.com

WhatsApp Us : +966532984612



Physical Config **GUI** Attributes

Wireless Tri-Band Home Router Firmware Version: v0.9.7

Wireless Setup Wireless Security Access Restrictions Applications & Gaming Administration Status
Basic Wireless Settings Wireless Security Guest Network Wireless MAC Filter Advanced Wireless Settings

Basic Wireless Settings Help...

2.4 GHz

Network Mode: Auto

Network Name (SSID): Networkforyou

SSID Broadcast: Enabled Disabled

Standard Channel: 1 - 2.412GHz

Channel Bandwidth: Auto

5 GHz - 2

Network Mode: Auto

Network Name (SSID): Networkforyou

SSID Broadcast: Enabled Disabled

Standard Channel: 165 - 5.825GHz

Channel Bandwidth: Auto

5 GHz - 1

Network Mode: Auto

Network Name (SSID): Networkforyou

SSID Broadcast: Enabled Disabled

Standard Channel: Auto

Channel Bandwidth: Auto

Email us:
networkforyou4@gmail.com

WhatsApp Us : +966532984612



Wireless Tri-Band Home Router Firmware Version: v0.9.7

Wireless Setup Wireless **Security** Access Restrictions Applications & Gaming Administration Status

Basic Wireless Settings Wireless Security Guest Network Wireless MAC Filter Advanced Wireless Settings

Wireless Security

Help...

2.4 GHz

Security Mode:

Encryption:

Passphrase:

Key Renewal: seconds

5 GHz - 1

Security Mode:

Encryption:

Passphrase:

Key Renewal: seconds

5 GHz - 2

Security Mode:

Encryption:

Passphrase:

Key Renewal: seconds

<https://emanim.szialab.org/index.html>

Email us:
networkforyou4@gmail.com

26 of 33

WhatsApp Us : +966532984612



Wireless Architectures:

Let have a look on different CISCO Wireless Architectures use in Enterprise Networks.

Autonomous AP Architecture:

- Autonomous Architecture, access points (APs) are **stand-alone**.
- Autonomous AP has all required intelligence to serve wireless clients & to connect wired.
- The Autonomous APs are stand-alone access points (AP) with **fully integrated intelligence**.

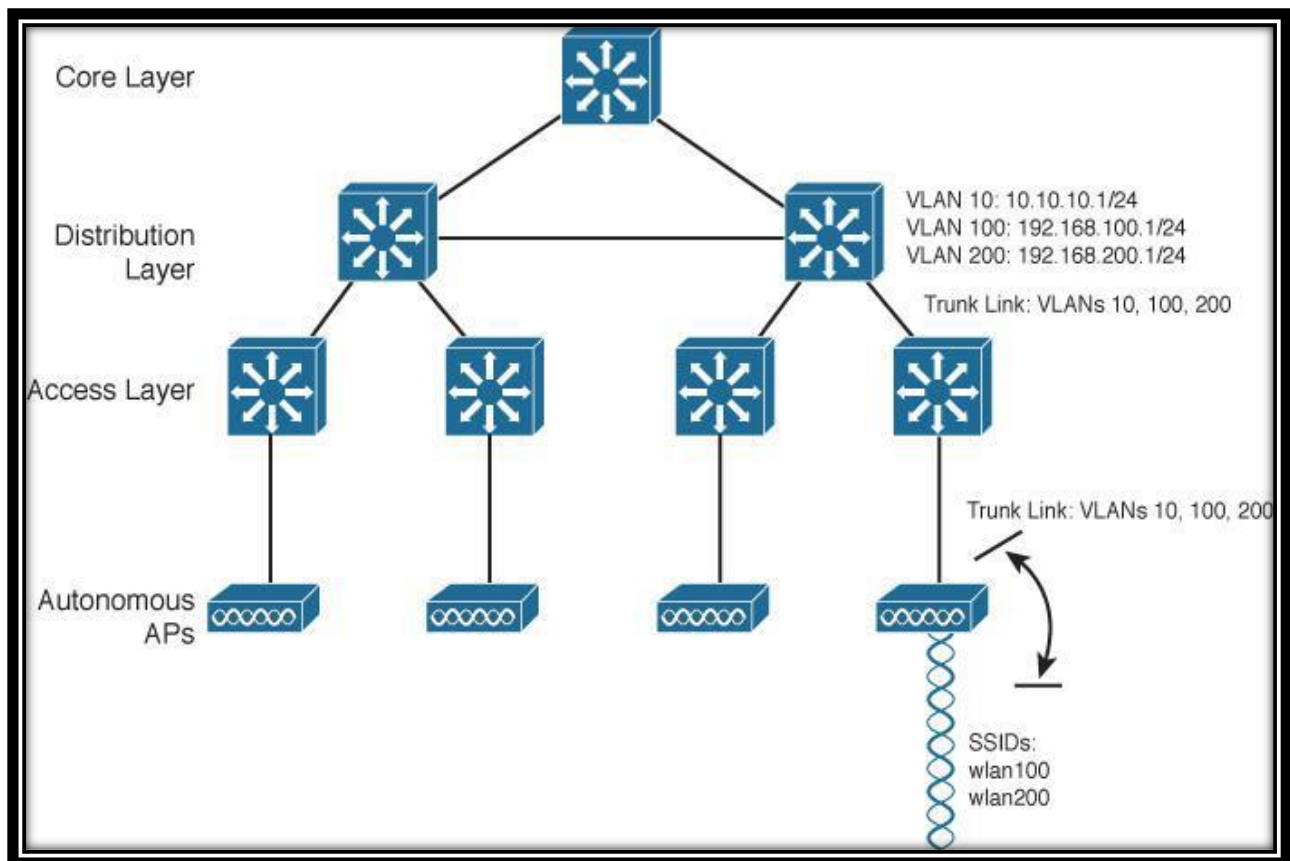

Autonomous APs work alone; we need to configure one by one this is a drawback for using Autonomous Aps.



Cloud-Based Architecture:

- Cloud-based AP management function is pushed out of the Enterprise into Internet cloud.
- Cisco Meraki is a cloud based solution that offers centralized management of the Wireless.
- Network is arranged same as autonomous AP, but managed would be redirected to a cloud.
- Where AP management function is pushed out of enterprise and into the Internet cloud.
- From cloud, can push out code upgrades & configuration changes to APs in the enterprise.
- Cloud-Based all of APs are managed, controlled, and monitored centrally from the cloud.

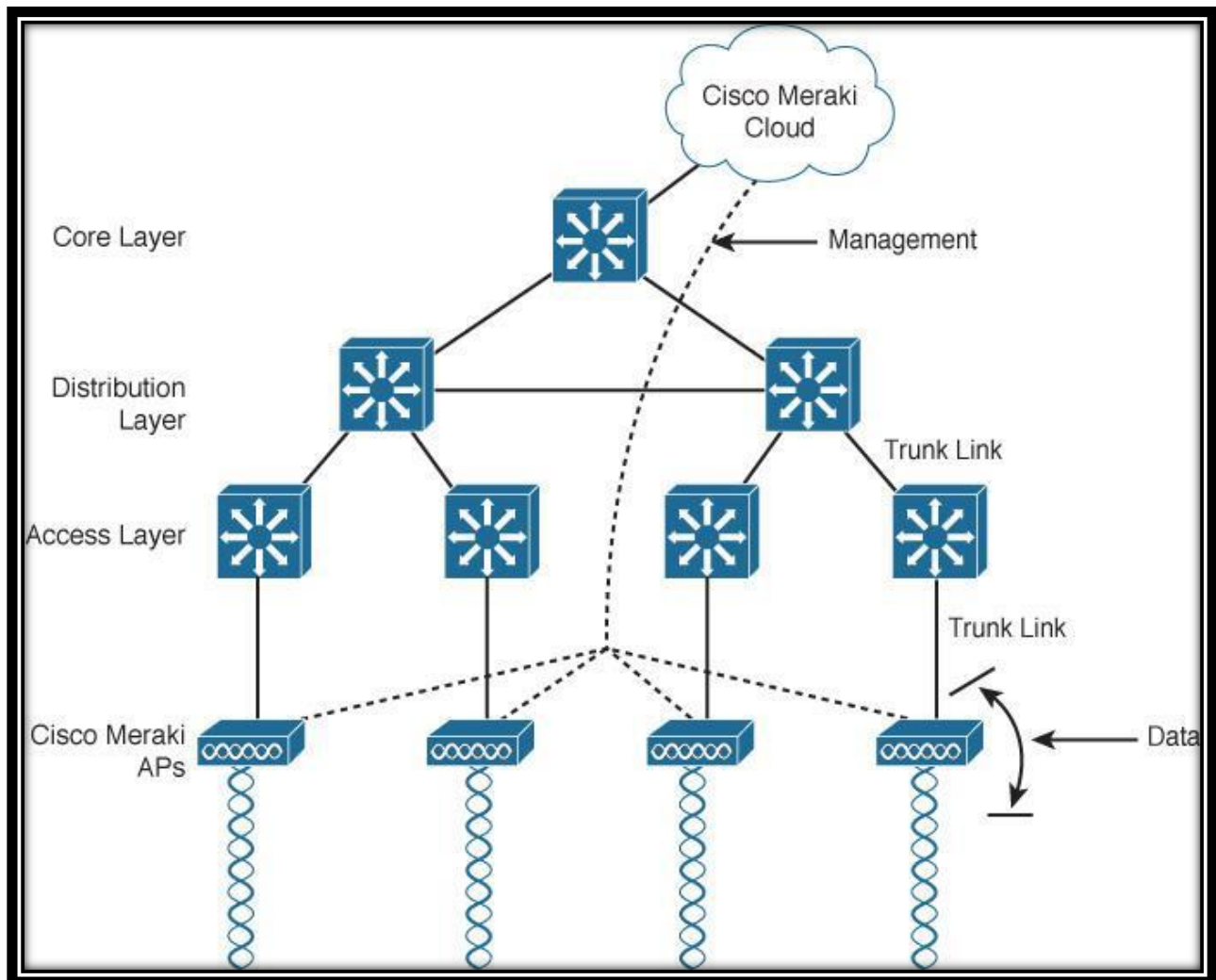

Email us:
networkforyou4@gmail.com

28 of 33

WhatsApp Us : +966532984612



Centralized Wireless Network:

- WLC for multiple APs, where do set up WLC so that it can cover as much APs as it can.
- For that we set the WLC in the core layer, to have a centralized view of the network.
- If you want to deploy a WLC to support the multiple lightweight APs in your network.
- One approach is locate WLC in central location that maximize number of APs joined it.
- Traffic to & from wireless users travel over CAPWAP tunnels (Control and Provisioning of Wireless Access Points (CAPWAP) tunneling protocol) reach into center of network.
- Centralized WLC provides convenient place to enforce security policies that affect all users.
- All management functions are usually performed on a wireless LAN Controller (WLAC).

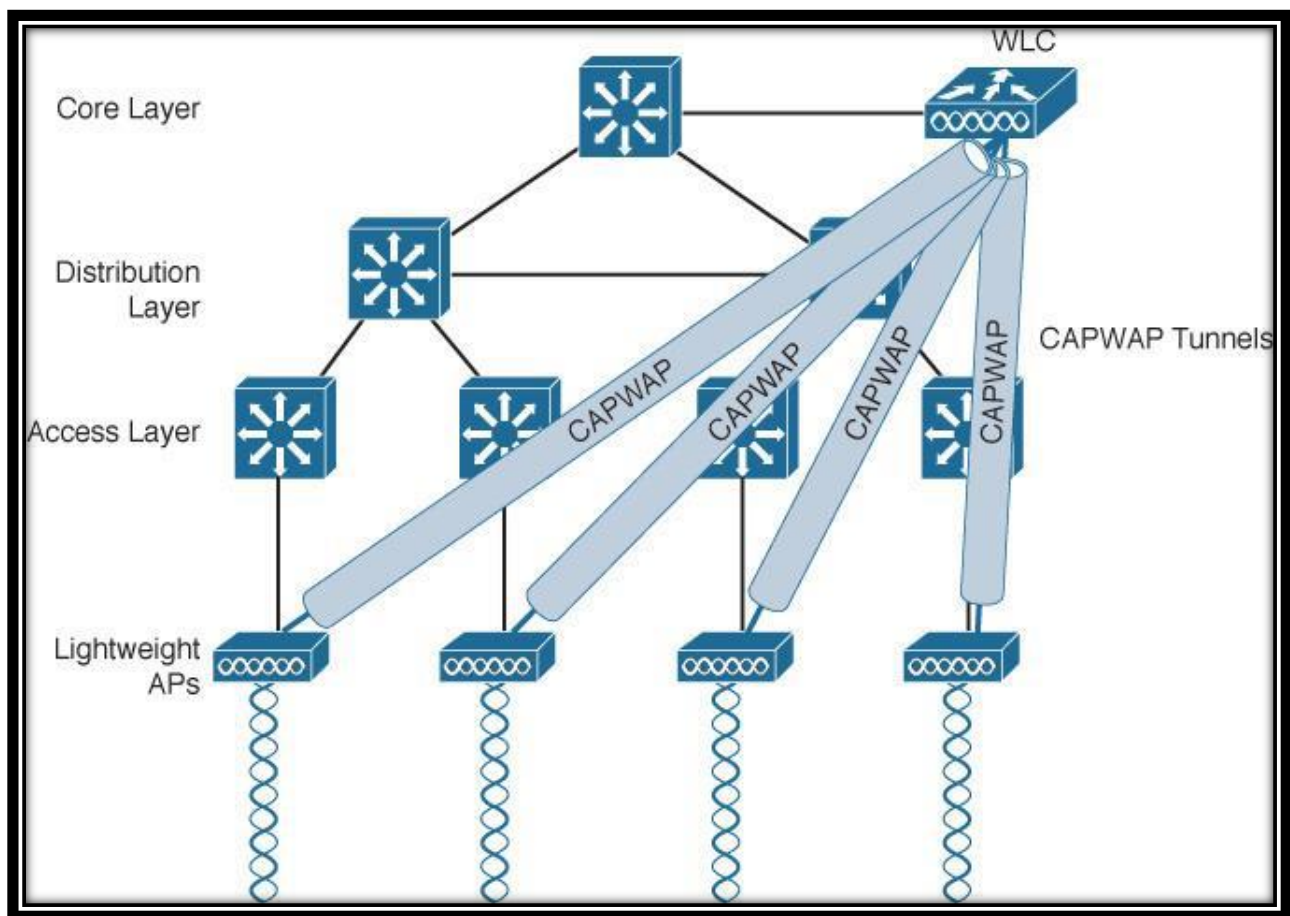

Email us:
networkforyou4@gmail.com

29 of 33

WhatsApp Us : +966532984612

Split-MAC Architecture:

- Split-MAC means is that management process is divided into two separate streams of data.
- Access points get configuration from designated controller.
- Wireless Controller has the ability to see all access points & coordinate them accordingly.
- Entire data process is going to be handled by the Wireless Access Points (AP) themselves.
- Real-time functions always stay in the AP and the management functions go to the WLC.

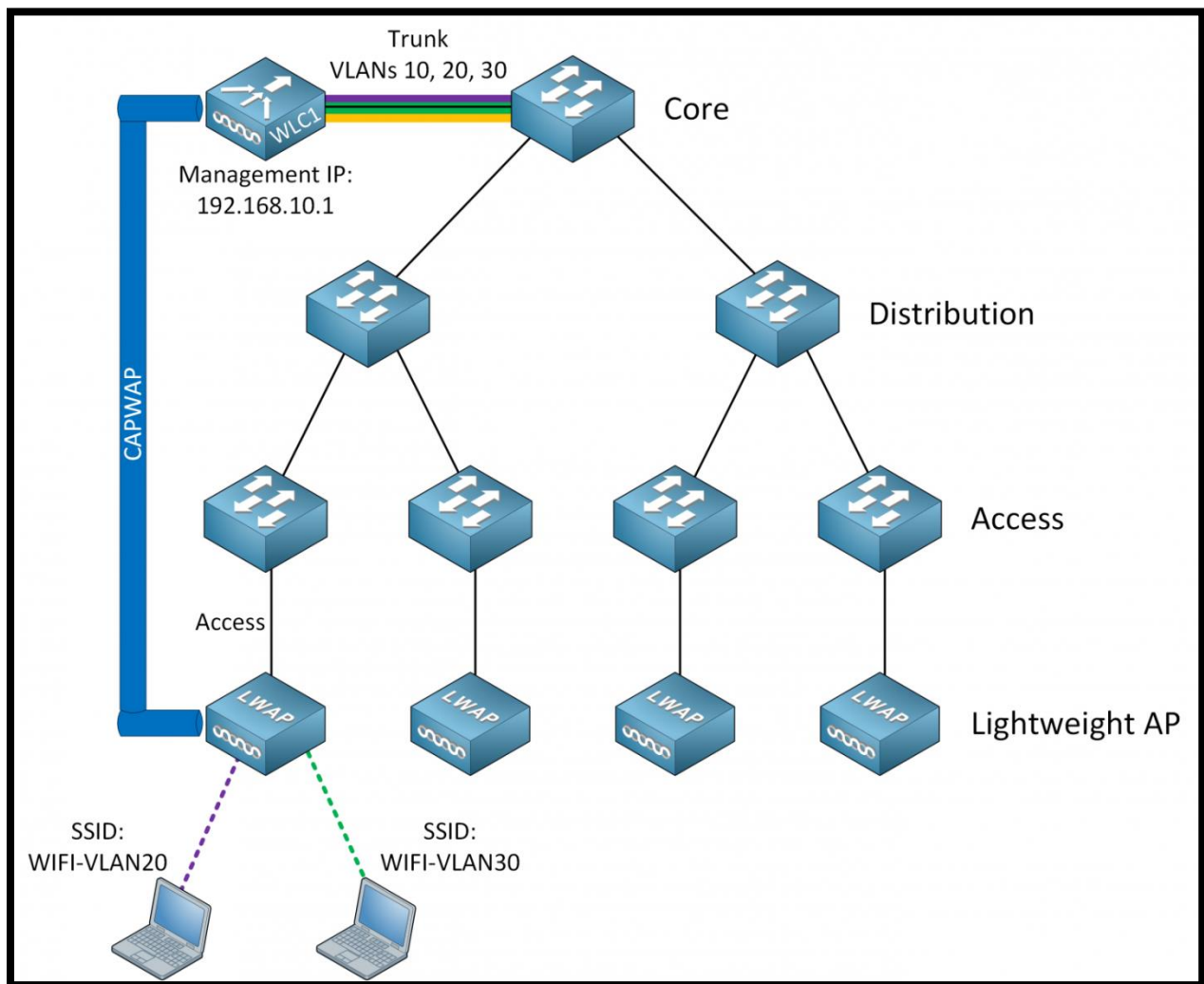



Encryption and Decryption:

- Encryption is the process of translating plain text data (plaintext) into something that appears to be random and meaningless (ciphertext).
- Decryption is the process of converting ciphertext back to plaintext.
- To decrypt a particular piece of ciphertext, the key that was used to encrypt the data must be used.

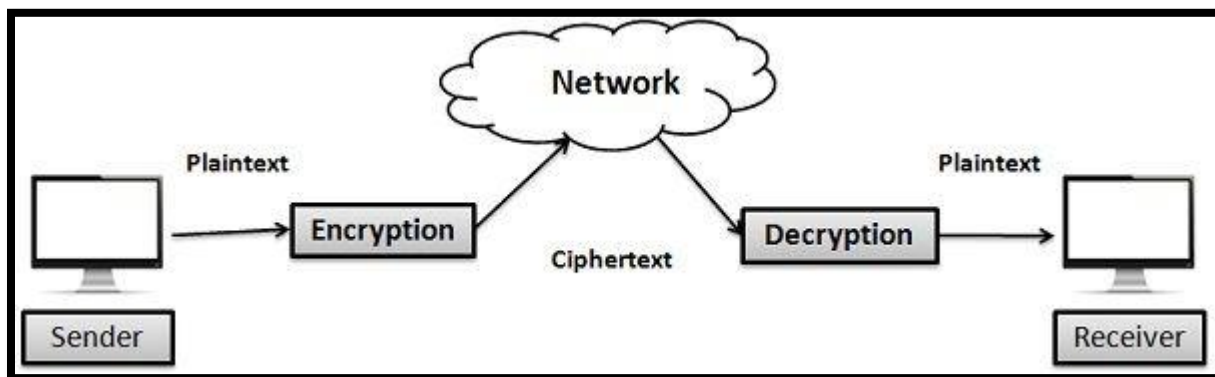
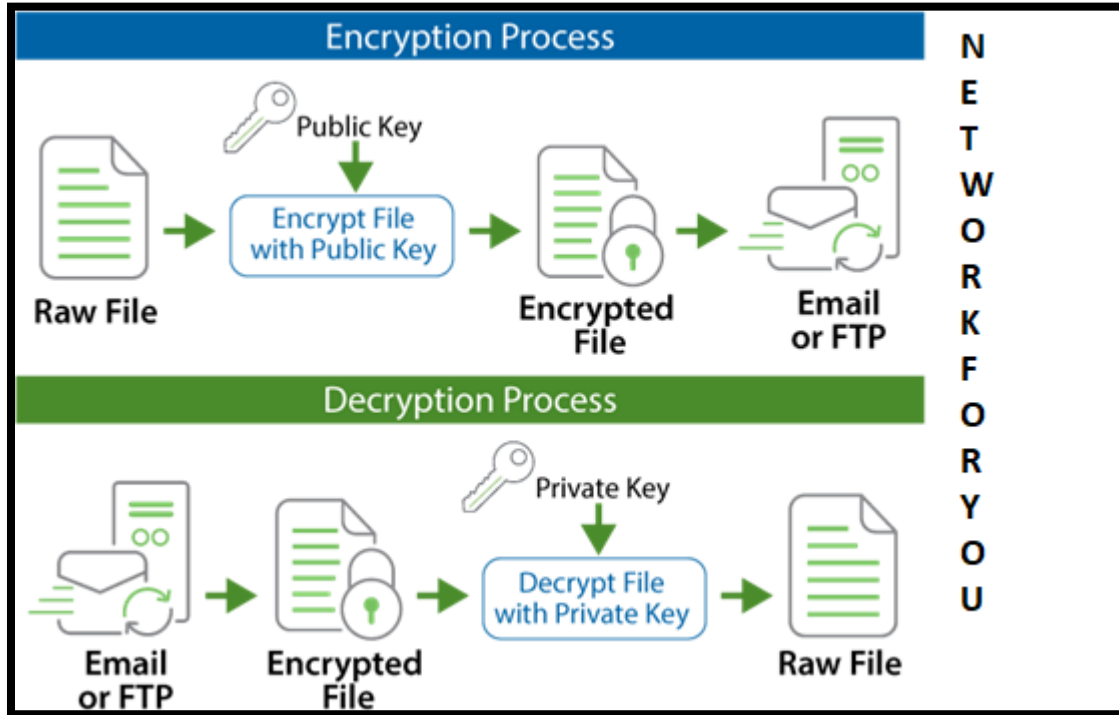

Email us:
networkforyou4@gmail.com

WhatsApp Us : +966532984612



Non overlapping Wi-Fi channels:

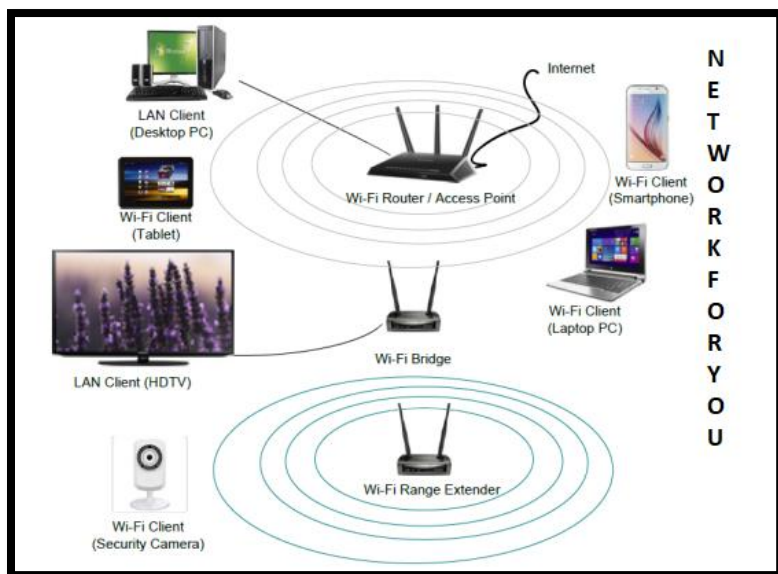

- Was your WiFi network working fine and now you're suddenly stuck with slow WiFi data rates?
- Selecting the proper WiFi channel can significantly improve your WiFi coverage and performance.
- **In the 2.4 GHz band, 1, 6, and 11 are the only non-overlapping channels.**
- Selecting one or more of these channels is an important part of setting up your network correctly.
- Currently, many wireless routers automatically select the channel for you upon initial setup, where depending on your wireless environment,
- It could lead to slow WiFi speeds and interference.
- Wireless interference occurs when something disrupts or weakens the Wi-Fi signal coming from the wireless router.
- Because this radio band is shared with other devices in the home, interference from other radio signals can affect your Wi-Fi networks.

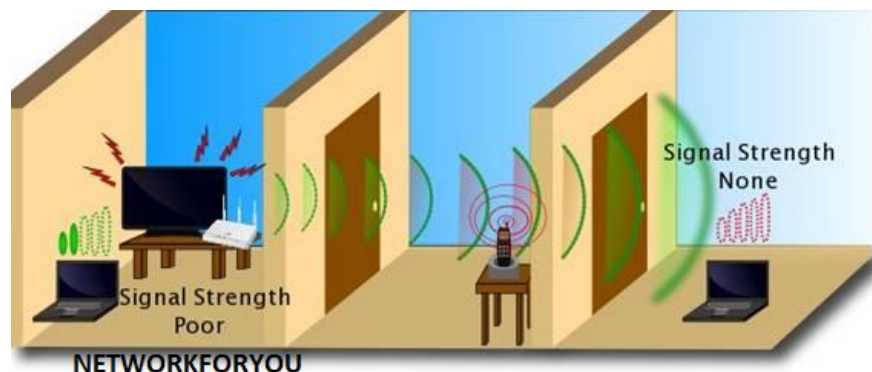

Email us:
networkforyou4@gmail.com

32 of 33

WhatsApp Us : +966532984612



- Avoid Interfering Devices like cell phones, cordless phones; microwaves can often interfere with your signal.
- Suggestions would be to move the router as far as you can from the interfering appliances.

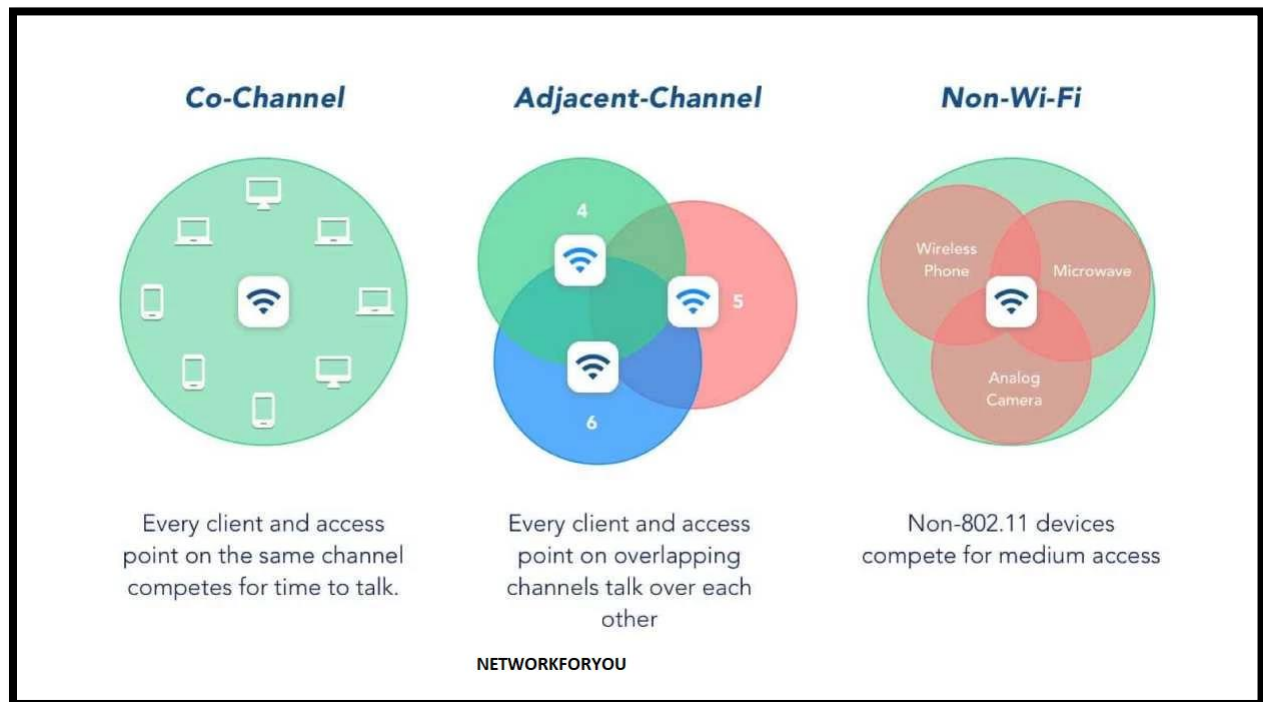

Email us:
networkforyou4@gmail.com

WhatsApp Us : +966532984612