



A Tour of C++

Second Edition

Bjarne Stroustrup



<https://t.me/learningnets>

C++ In-Depth Series

Bjarne Stroustrup

A Tour of C++

Second Edition

C++ In-Depth Series

Bjarne Stroustrup, Series Editor

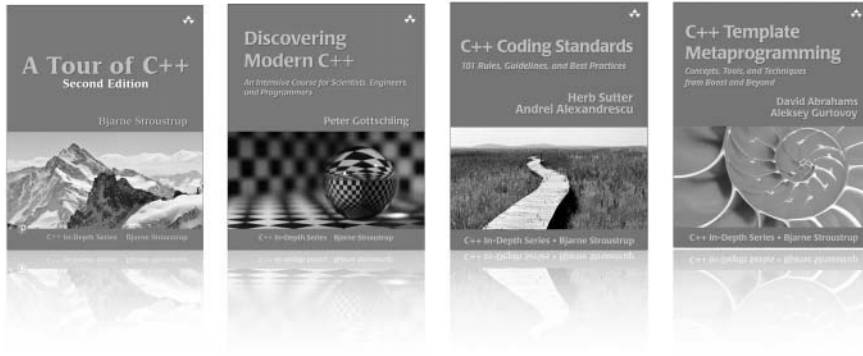

Visit informit.com/series/indepth for a complete list of available publications.

The C++ In-Depth Series is a collection of concise and focused books that provide real-world programmers with reliable information about the C++ programming language.

Selected by the designer and original implementor of C++, Bjarne Stroustrup, and written by carefully chosen experts in the field, each book in this series presents either a single topic, at a technical level appropriate to that topic, or a fast-paced overview, for a quick understanding of broader language features. In either case, the series' practical approach is designed to lift professionals (and aspiring professionals) to the next level of programming skill or knowledge.



Make sure to connect with us!
informit.com/socialconnect

 Pearson
Addison-Wesley

informIT.com
the trusted technology learning source

<https://t.me/learningnets>

A Tour of C++ Second Edition

Bjarne Stroustrup

↕ Addison-Wesley

Boston • Columbus • New York • San Francisco • Amsterdam • Cape Town
Dubai • London • Madrid • Milan • Munich • Paris • Montreal • Toronto • Delhi • Mexico City
São Paulo • Sydney • Hong Kong • Seoul • Singapore • Taipei • Tokyo

<https://t.me/learningnets>

Many of the designations used by manufacturers and sellers to distinguish their products are claimed as trademarks. Where those designations appear in this book, and the publisher was aware of a trademark claim, the designations have been printed with initial capital letters or in all capitals.

The author and publisher have taken care in the preparation of this book, but make no expressed or implied warranty of any kind and assume no responsibility for errors or omissions. No liability is assumed for incidental or consequential damages in connection with or arising out of the use of the information or programs contained herein.

For information about buying this title in bulk quantities, or for special sales opportunities (which may include electronic versions; custom cover designs; and content particular to your business, training goals, marketing focus, or branding interests), please contact our corporate sales department at corpsales@pearsoned.com or (800) 382-3419.

For government sales inquiries, please contact governmentsales@pearsoned.com.

For questions about sales outside the U.S., please contact intlcs@pearson.com.

Visit us on the Web: informit.com/aw

Library of Congress Control Number: 2018941627

Copyright © 2018 by Pearson Education, Inc.

All rights reserved. This publication is protected by copyright, and permission must be obtained from the publisher prior to any prohibited reproduction, storage in a retrieval system, or transmission in any form or by any means, electronic, mechanical, photocopying, recording, or likewise. For information regarding permissions, request forms and the appropriate contacts within the Pearson Education Global Rights & Permissions Department, please visit www.pearsoned.com/permissions/.

This book was typeset in Times and Helvetica by the author.

ISBN-13: 978-0-13-499783-4

ISBN-10: 0-13-499783-2

Third printing, March 2019

3 19

Contents

Preface	xi
1 The Basics	1
1.1 Introduction	1
1.2 Programs	2
1.3 Functions	4
1.4 Types, Variables, and Arithmetic	5
1.5 Scope and Lifetime	9
1.6 Constants	9
1.7 Pointers, Arrays, and References	11
1.8 Tests	14
1.9 Mapping to Hardware	16
1.10 Advice	18
2 User-Defined Types	21
2.1 Introduction	21
2.2 Structures	22
2.3 Classes	23
2.4 Unions	25
2.5 Enumerations	26
2.6 Advice	27

3 Modularity	29
3.1 Introduction	29
3.2 Separate Compilation	30
3.3 Modules (C++20)	32
3.4 Namespaces	34
3.5 Error Handling	35
3.6 Function Arguments and Return Values	36
3.7 Advice	46
4 Classes	47
4.1 Introduction	47
4.2 Concrete Types	48
4.3 Abstract Types	54
4.4 Virtual Functions	56
4.5 Class Hierarchies	57
4.6 Advice	63
5 Essential Operations	65
5.1 Introduction	65
5.2 Copy and Move	68
5.3 Resource Management	72
5.4 Conventional Operations	74
5.5 Advice	77
6 Templates	79
6.1 Introduction	79
6.2 Parameterized Types	79
6.3 Parameterized Operations	84
6.4 Template Mechanisms	89
6.5 Advice	92
7 Concepts and Generic Programming	93
7.1 Introduction	93
7.2 Concepts	94
7.3 Generic Programming	98
7.4 Variadic Templates	100
7.5 Template Compilation Model	104
7.6 Advice	104

8 Library Overview	107
8.1 Introduction	107
8.2 Standard-Library Components	108
8.3 Standard-Library Headers and Namespace	109
8.4 Advice	110
9 Strings and Regular Expressions	111
9.1 Introduction	111
9.2 Strings	111
9.3 String Views	114
9.4 Regular Expressions	116
9.5 Advice	122
10 Input and Output	123
10.1 Introduction	123
10.2 Output	123
10.3 Input	125
10.4 I/O State	127
10.5 I/O of User-Defined Types	128
10.6 Formatting	129
10.7 File Streams	130
10.8 String Streams	130
10.9 C-style I/O	131
10.10 File System	132
10.11 Advice	136
11 Containers	137
11.1 Introduction	137
11.2 vector	138
11.3 list	142
11.4 map	144
11.5 unordered_map	144
11.6 Container Overview	146
11.7 Advice	148
12 Algorithms	149
12.1 Introduction	149
12.2 Use of Iterators	150
12.3 Iterator Types	153

- 12.4 Stream Iterators 154
- 12.5 Predicates 155
- 12.6 Algorithm Overview 156
- 12.7 Concepts (C++20) 157
- 12.8 Container Algorithms 160
- 12.9 Parallel Algorithms 161
- 12.10 Advice 161

13 Utilities

163

- 13.1 Introduction 163
- 13.2 Resource Management 164
- 13.3 Range Checking: **span** 168
- 13.4 Specialized Containers 170
- 13.5 Alternatives 174
- 13.6 Allocators 178
- 13.7 Time 179
- 13.8 Function Adaption 180
- 13.9 Type Functions 181
- 13.10 Advice 185

14 Numerics

187

- 14.1 Introduction 187
- 14.2 Mathematical Functions 188
- 14.3 Numerical Algorithms 189
- 14.4 Complex Numbers 190
- 14.5 Random Numbers 191
- 14.6 Vector Arithmetic 192
- 14.7 Numeric Limits 193
- 14.8 Advice 193

15 Concurrency

195

- 15.1 Introduction 195
- 15.2 Tasks and **threads** 196
- 15.3 Passing Arguments 197
- 15.4 Returning Results 198
- 15.5 Sharing Data 199
- 15.6 Waiting for Events 200
- 15.7 Communicating Tasks 202
- 15.8 Advice 205

16 History and Compatibility	207
16.1 History	207
16.2 C++ Feature Evolution	214
16.3 C/C++ Compatibility	218
16.4 Bibliography	222
16.5 Advice	225
Index	227

This page intentionally left blank

Preface

*When you wish to instruct,
be brief.
– Cicero*

C++ feels like a new language. That is, I can express my ideas more clearly, more simply, and more directly today than I could in C++98. Furthermore, the resulting programs are better checked by the compiler and run faster.

This book gives an overview of C++ as defined by C++17, the current ISO C++ standard, and implemented by the major C++ suppliers. In addition, it mentions concepts and modules, as defined in ISO Technical Specifications and in current use, but not scheduled for inclusion into the standard until C++20.

Like other modern languages, C++ is large and there are a large number of libraries needed for effective use. This thin book aims to give an experienced programmer an idea of what constitutes modern C++. It covers most major language features and the major standard-library components. This book can be read in just a few hours but, obviously, there is much more to writing good C++ than can be learned in a day. However, the aim here is not mastery, but to give an overview, to give key examples, and to help a programmer get started.

The assumption is that you have programmed before. If not, please consider reading a text-book, such as *Programming: Principles and Practice Using C++ (Second edition)* [Stroustrup,2014], before continuing here. Even if you have programmed before, the language you used or the applications you wrote may be very different from the style of C++ presented here.

Think of a sightseeing tour of a city, such as Copenhagen or New York. In just a few hours, you are given a quick peek at the major attractions, told a few background stories, and given some suggestions about what to do next. You do *not* know the city after such a tour. You do *not* understand all you have seen and heard. You do *not* know how to navigate the formal and informal rules that govern life in the city. To really know a city, you have to live in it, often for years. However, with a bit of luck, you will have gained a bit of an overview, a notion of what is special about the city, and ideas of what might be of interest to you. After the tour, the real exploration can begin.

This tour presents the major C++ language features as they support programming styles, such as object-oriented and generic programming. It does not attempt to provide a detailed, reference-manual, feature-by-feature view of the language. In the best textbook tradition, I try to explain a feature before I use it, but that is not always possible and not everybody reads the text strictly sequentially. So, the reader is encouraged to use the cross references and the index.

Similarly, this tour presents the standard libraries in terms of examples, rather than exhaustively. It does not describe libraries beyond those defined by the ISO standard. The reader can search out supporting material as needed. [Stroustrup,2013] and [Stroustrup,2014] are examples of such material, but there is an enormous amount of material (of varying quality) available on the Web, e.g., [Cpference]. For example, when I mention a standard-library function or class, its definition can easily be looked up, and by examining its documentation, many related facilities can be found.

This tour presents C++ as an integrated whole, rather than as a layer cake. Consequently, it does not identify language features as present in C, part of C++98, or new in C++11, C++14, or C++17. Such information can be found in Chapter 16 (History and Compatibility). I focus on fundamentals and try to be brief, but I have not completely resisted the temptation to overrepresent novel features. This also seems to satisfy the curiosity of many readers who already know some older version of C++.

A programming language reference manual or standard simply states what can be done, but programmers are often more interested in learning how to use the language well. This aspect is partly addressed in the selection of topics covered, partly in the text, and specifically in the advice sections. More advice about what constitutes *good modern C++* can be found in the C++ Core Guidelines [Stroustrup,2015]. The core guidelines can be a good source for further exploration of the ideas presented in this book. You may note a remarkable similarity of the advice formulation and even the numbering of advice between the Core Guidelines and this book. One reason is that the first edition of *A Tour of C++* was a major source of the initial Core Guidelines.

Acknowledgments

Some of the material presented here is borrowed from TC++PL4 [Stroustrup,2013], so thanks to all who helped completing that book.

Thanks to all who help complete and correct the first edition of “A Tour of C++.”

Thanks to Morgan Stanley for giving me time to write this second edition. Thanks to the Columbia University Spring 2018 “Design Using C++” class for finding many a typo and bug in an early draft of this book and for making many constructive suggestions.

Thanks to Paul Anderson, Chuck Allison, Peter Gottschling, William Mon, Charles Wilson, and Sergey Zubkov for reviewing the book and suggesting many improvements.

Manhattan, New York

Bjarne Stroustrup

The Basics

*The first thing we do, let's
kill all the language lawyers.
– Henry VI, Part II*

- Introduction
- Programs
 - Hello, World!
- Functions
- Types, Variables, and Arithmetic
 - Arithmetic; Initialization
- Scope and Lifetime
- Constants
- Pointers, Arrays, and References
 - The Null Pointer
- Tests
- Mapping to Hardware
 - Assignment; Initialization
- Advice

1.1 Introduction

This chapter informally presents the notation of C++, C++'s model of memory and computation, and the basic mechanisms for organizing code into a program. These are the language facilities supporting the styles most often seen in C and sometimes called *procedural programming*.

1.2 Programs

C++ is a compiled language. For a program to run, its source text has to be processed by a compiler, producing object files, which are combined by a linker yielding an executable program. A C++ program typically consists of many source code files (usually simply called *source files*).

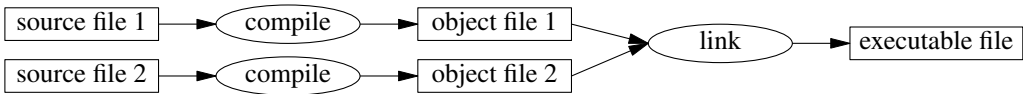

An executable program is created for a specific hardware/system combination; it is not portable, say, from a Mac to a Windows PC. When we talk about portability of C++ programs, we usually mean portability of source code; that is, the source code can be successfully compiled and run on a variety of systems.

The ISO C++ standard defines two kinds of entities:

- *Core language features*, such as built-in types (e.g., **char** and **int**) and loops (e.g., **for**-statements and **while**-statements)
- *Standard-library components*, such as containers (e.g., **vector** and **map**) and I/O operations (e.g., **<<** and **getline()**)

The standard-library components are perfectly ordinary C++ code provided by every C++ implementation. That is, the C++ standard library can be implemented in C++ itself and is (with very minor uses of machine code for things such as thread context switching). This implies that C++ is sufficiently expressive and efficient for the most demanding systems programming tasks.

C++ is a statically typed language. That is, the type of every entity (e.g., object, value, name, and expression) must be known to the compiler at its point of use. The type of an object determines the set of operations applicable to it.

1.2.1 Hello, World!

The minimal C++ program is

```
int main() { }      // the minimal C++ program
```

This defines a function called **main**, which takes no arguments and does nothing.

Curly braces, **{ }**, express grouping in C++. Here, they indicate the start and end of the function body. The double slash, **//**, begins a comment that extends to the end of the line. A comment is for the human reader; the compiler ignores comments.

Every C++ program must have exactly one global function named **main()**. The program starts by executing that function. The **int** integer value returned by **main()**, if any, is the program's return value to "the system." If no value is returned, the system will receive a value indicating successful completion. A nonzero value from **main()** indicates failure. Not every operating system and execution environment make use of that return value: Linux/Unix-based environments do, but Windows-based environments rarely do.

Typically, a program produces some output. Here is a program that writes **Hello, World!**:

```
#include <iostream>

int main()
{
    std::cout << "Hello, World!\n";
}
```

The line `#include <iostream>` instructs the compiler to *include* the declarations of the standard stream I/O facilities as found in `iostream`. Without these declarations, the expression

```
std::cout << "Hello, World!\n"
```

would make no sense. The operator `<<` (“put to”) writes its second argument onto its first. In this case, the string literal `"Hello, World!\n"` is written onto the standard output stream `std::cout`. A string literal is a sequence of characters surrounded by double quotes. In a string literal, the backslash character `\` followed by another character denotes a single “special character.” In this case, `\n` is the newline character, so that the characters written are **Hello, World!** followed by a newline.

The `std::` specifies that the name `cout` is to be found in the standard-library namespace (§3.4). I usually leave out the `std::` when discussing standard features; §3.4 shows how to make names from a namespace visible without explicit qualification.

Essentially all executable code is placed in functions and called directly or indirectly from `main()`. For example:

```
#include <iostream>           // include ("import") the declarations for the I/O stream library

using namespace std;        // make names from std visible without std:: (§3.4)

double square(double x)     // square a double precision floating-point number
{
    return x*x;
}

void print_square(double x)
{
    cout << "the square of " << x << " is " << square(x) << "\n";
}

int main()
{
    print_square(1.234);     // print: the square of 1.234 is 1.52276
}
```

A “return type” `void` indicates that a function does not return a value.

1.3 Functions

The main way of getting something done in a C++ program is to call a function to do it. Defining a function is the way you specify how an operation is to be done. A function cannot be called unless it has been previously declared.

A function declaration gives the name of the function, the type of the value returned (if any), and the number and types of the arguments that must be supplied in a call. For example:

```
Elem* next_elem();      // no argument; return a pointer to Elem (an Elem*)
void exit(int);        // int argument; return nothing
double sqrt(double);   // double argument; return a double
```

In a function declaration, the return type comes before the name of the function and the argument types come after the name enclosed in parentheses.

The semantics of argument passing are identical to the semantics of initialization (§3.6.1). That is, argument types are checked and implicit argument type conversion takes place when necessary (§1.4). For example:

```
double s2 = sqrt(2);    // call sqrt() with the argument double{2}
double s3 = sqrt("three"); // error: sqrt() requires an argument of type double
```

The value of such compile-time checking and type conversion should not be underestimated.

A function declaration may contain argument names. This can be a help to the reader of a program, but unless the declaration is also a function definition, the compiler simply ignores such names. For example:

```
double sqrt(double d); // return the square root of d
double square(double); // return the square of the argument
```

The type of a function consists of its return type and the sequence of its argument types. For example:

```
double get(const vector<double>& vec, int index); // type: double(const vector<double>&,int)
```

A function can be a member of a class (§2.3, §4.2.1). For such a *member function*, the name of its class is also part of the function type. For example:

```
char& String::operator[](int index); // type: char& String::(int)
```

We want our code to be comprehensible, because that is the first step on the way to maintainability. The first step to comprehensibility is to break computational tasks into meaningful chunks (represented as functions and classes) and name those. Such functions then provide the basic vocabulary of computation, just as the types (built-in and user-defined) provide the basic vocabulary of data. The C++ standard algorithms (e.g., **find**, **sort**, and **iota**) provide a good start (Chapter 12). Next, we can compose functions representing common or specialized tasks into larger computations.

The number of errors in code correlates strongly with the amount of code and the complexity of the code. Both problems can be addressed by using more and shorter functions. Using a function to do a specific task often saves us from writing a specific piece of code in the middle of other code; making it a function forces us to name the activity and document its dependencies.

If two functions are defined with the same name, but with different argument types, the compiler will choose the most appropriate function to invoke for each call. For example:

```

void print(int);      // takes an integer argument
void print(double);  // takes a floating-point argument
void print(string);  // takes a string argument

void user()
{
    print(42);        // calls print(int)
    print(9.65);     // calls print(double)
    print("Barcelona"); // calls print(string)
}

```

If two alternative functions could be called, but neither is better than the other, the call is deemed ambiguous and the compiler gives an error. For example:

```

void print(int,double);
void print(double,int);

void user2()
{
    print(0,0);      // error: ambiguous
}

```

Defining multiple functions with the same name is known as *function overloading* and is one of the essential parts of generic programming (§7.2). When a function is overloaded, each function of the same name should implement the same semantics. The `print()` functions are an example of this; each `print()` prints its argument.

1.4 Types, Variables, and Arithmetic

Every name and every expression has a type that determines the operations that may be performed on it. For example, the declaration

```
int inch;
```

specifies that `inch` is of type `int`; that is, `inch` is an integer variable.

A *declaration* is a statement that introduces an entity into the program. It specifies a type for the entity:

- A *type* defines a set of possible values and a set of operations (for an object).
- An *object* is some memory that holds a value of some type.
- A *value* is a set of bits interpreted according to a type.
- A *variable* is a named object.

C++ offers a small zoo of fundamental types, but since I'm not a zoologist, I will not list them all. You can find them all in reference sources, such as [Stroustrup,2013] or the [Cppreference] on the Web. Examples are:

```

bool           // Boolean, possible values are true and false
char          // character, for example, 'a', 'z', and '9'
int           // integer, for example, -273, 42, and 1066
double        // double-precision floating-point number, for example, -273.15, 3.14, and 6.626e-34
unsigned      // non-negative integer, for example, 0, 1, and 999 (use for bitwise logical operations)

```

Each fundamental type corresponds directly to hardware facilities and has a fixed size that determines the range of values that can be stored in it:

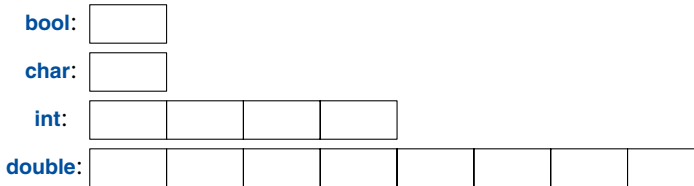

A **char** variable is of the natural size to hold a character on a given machine (typically an 8-bit byte), and the sizes of other types are multiples of the size of a **char**. The size of a type is implementation-defined (i.e., it can vary among different machines) and can be obtained by the **sizeof** operator; for example, **sizeof(char)** equals **1** and **sizeof(int)** is often **4**.

Numbers can be floating-point or integers.

- Floating-point numbers are recognized by a decimal point (e.g., **3.14**) or by an exponent (e.g., **3e-2**).
- Integer literals are by default decimal (e.g., **42** means forty-two). A **0b** prefix indicates a binary (base 2) integer literal (e.g., **0b10101010**). A **0x** prefix indicates a hexadecimal (base 16) integer literal (e.g., **0xBAD1234**). A **0** prefix indicates an octal (base 8) integer literal (e.g., **0334**).

To make long literals more readable for humans, we can use a single quote (**'**) as a digit separator. For example, π is about **3.14159'26535'89793'23846'26433'83279'50288** or if you prefer hexadecimal **0x3.243F'6A88'85A3'08D3**.

1.4.1 Arithmetic

The arithmetic operators can be used for appropriate combinations of the fundamental types:

```

x+y           // plus
+x           // unary plus
x-y           // minus
-x           // unary minus
x*y           // multiply
x/y           // divide
x%y          // remainder (modulus) for integers

```

So can the comparison operators:

```

x==y    // equal
x!=y    // not equal
x<y     // less than
x>y     // greater than
x<=y    // less than or equal
x>=y    // greater than or equal

```

Furthermore, logical operators are provided:

```

x&y     // bitwise and
x|y     // bitwise or
x^y     // bitwise exclusive or
~x      // bitwise complement
x&& y    // logical and
x||y    // logical or
!x      // logical not (negation)

```

A bitwise logical operator yields a result of the operand type for which the operation has been performed on each bit. The logical operators **&&** and **||** simply return **true** or **false** depending on the values of their operands.

In assignments and in arithmetic operations, C++ performs all meaningful conversions between the basic types so that they can be mixed freely:

```

void some_function()    // function that doesn't return a value
{
    double d = 2.2;      // initialize floating-point number
    int i = 7;           // initialize integer
    d = d+i;            // assign sum to d
    i = d*i;            // assign product to i; beware: truncating the double d*i to an int
}

```

The conversions used in expressions are called *the usual arithmetic conversions* and aim to ensure that expressions are computed at the highest precision of its operands. For example, an addition of a **double** and an **int** is calculated using double-precision floating-point arithmetic.

Note that **=** is the assignment operator and **==** tests equality.

In addition to the conventional arithmetic and logical operators, C++ offers more specific operations for modifying a variable:

```

x+=y    // x = x+y
++x     // increment: x = x+1
x-=y    // x = x-y
--x     // decrement: x = x-1
x*=y    // scaling: x = x*y
x/=y    // scaling: x = x/y
x%=y    // x = x%y

```

These operators are concise, convenient, and very frequently used.

The order of evaluation of expressions is left to right, except for assignments, which are right-to-left. The order of evaluation of function arguments is unfortunately unspecified.

1.4.2 Initialization

Before an object can be used, it must be given a value. C++ offers a variety of notations for expressing initialization, such as the `=` used above, and a universal form based on curly-brace-delimited initializer lists:

```
double d1 = 2.3;           // initialize d1 to 2.3
double d2 {2.3};         // initialize d2 to 2.3
double d3 = {2.3};       // initialize d3 to 2.3 (the = is optional with { ... })
complex<double> z = 1;    // a complex number with double-precision floating-point scalars
complex<double> z2 {d1,d2};
complex<double> z3 = {d1,d2}; // the = is optional with { ... }

vector<int> v {1,2,3,4,5,6}; // a vector of ints
```

The `=` form is traditional and dates back to C, but if in doubt, use the general `{}`-list form. If nothing else, it saves you from conversions that lose information:

```
int i1 = 7.8;           // i1 becomes 7 (surprise?)
int i2 {7.8};          // error: floating-point to integer conversion
```

Unfortunately, conversions that lose information, *narrowing conversions*, such as `double` to `int` and `int` to `char`, are allowed and implicitly applied when you use `=` (but not when you use `{}`). The problems caused by implicit narrowing conversions are a price paid for C compatibility (§16.3).

A constant (§1.6) cannot be left uninitialized and a variable should only be left uninitialized in extremely rare circumstances. Don't introduce a name until you have a suitable value for it. User-defined types (such as `string`, `vector`, `Matrix`, `Motor_controller`, and `Orc_warrior`) can be defined to be implicitly initialized (§4.2.1).

When defining a variable, you don't need to state its type explicitly when it can be deduced from the initializer:

```
auto b = true;          // a bool
auto ch = 'x';         // a char
auto i = 123;          // an int
auto d = 1.2;          // a double
auto z = sqrt(y);      // z has the type of whatever sqrt(y) returns
auto bb {true};        // bb is a bool
```

With `auto`, we tend to use the `=` because there is no potentially troublesome type conversion involved, but if you prefer to use `{}` initialization consistently, you can do that instead.

We use `auto` where we don't have a specific reason to mention the type explicitly. "Specific reasons" include:

- The definition is in a large scope where we want to make the type clearly visible to readers of our code.
- We want to be explicit about a variable's range or precision (e.g., `double` rather than `float`).

Using `auto`, we avoid redundancy and writing long type names. This is especially important in generic programming where the exact type of an object can be hard for the programmer to know and the type names can be quite long (§12.2).

1.5 Scope and Lifetime

A declaration introduces its name into a scope:

- *Local scope*: A name declared in a function (§1.3) or lambda (§6.3.2) is called a *local name*. Its scope extends from its point of declaration to the end of the block in which its declaration occurs. A *block* is delimited by a `{ }` pair. Function argument names are considered local names.
- *Class scope*: A name is called a *member name* (or a *class member name*) if it is defined in a class (§2.2, §2.3, Chapter 4), outside any function (§1.3), lambda (§6.3.2), or **enum class** (§2.5). Its scope extends from the opening `{` of its enclosing declaration to the end of that declaration.
- *Namespace scope*: A name is called a *namespace member name* if it is defined in a namespace (§3.4) outside any function, lambda (§6.3.2), class (§2.2, §2.3, Chapter 4), or **enum class** (§2.5). Its scope extends from the point of declaration to the end of its namespace.

A name not declared inside any other construct is called a *global name* and is said to be in the *global namespace*.

In addition, we can have objects without names, such as temporaries and objects created using **new** (§4.2.2). For example:

```
vector<int> vec;    // vec is global (a global vector of integers)

struct Record {
    string name;  // name is a member of Record (a string member)
    // ...
};

void fct(int arg) // fct is global (a global function)
                 // arg is local (an integer argument)
{
    string motto {"Who dares wins"}; // motto is local
    auto p = new Record{"Hume"};     // p points to an unnamed Record (created by new)
    // ...
}
```

An object must be constructed (initialized) before it is used and will be destroyed at the end of its scope. For a namespace object the point of destruction is the end of the program. For a member, the point of destruction is determined by the point of destruction of the object of which it is a member. An object created by **new** “lives” until destroyed by **delete** (§4.2.2).

1.6 Constants

C++ supports two notions of immutability:

- **const**: meaning roughly “I promise not to change this value.” This is used primarily to specify interfaces so that data can be passed to functions using pointers and references without fear of it being modified. The compiler enforces the promise made by **const**. The value of a **const** can be calculated at run time.

- **constexpr**: meaning roughly “to be evaluated at compile time.” This is used primarily to specify constants, to allow placement of data in read-only memory (where it is unlikely to be corrupted), and for performance. The value of a **constexpr** must be calculated by the compiler.

For example:

```
constexpr int dmv = 17;           // dmv is a named constant
int var = 17;                    // var is not a constant
const double sqv = sqrt(var);    // sqv is a named constant, possibly computed at run time

double sum(const vector<double>&); // sum will not modify its argument (§1.7)

vector<double> v {1.2, 3.4, 4.5}; // v is not a constant
const double s1 = sum(v);        // OK: sum(v) is evaluated at run time
constexpr double s2 = sum(v);   // error: sum(v) is not a constant expression
```

For a function to be usable in a *constant expression*, that is, in an expression that will be evaluated by the compiler, it must be defined **constexpr**. For example:

```
constexpr double square(double x) { return x*x; }

constexpr double max1 = 1.4*square(17); // OK 1.4*square(17) is a constant expression
constexpr double max2 = 1.4*square(var); // error: var is not a constant expression
const double max3 = 1.4*square(var);    // OK, may be evaluated at run time
```

A **constexpr** function can be used for non-constant arguments, but when that is done the result is not a constant expression. We allow a **constexpr** function to be called with non-constant-expression arguments in contexts that do not require constant expressions. That way, we don’t have to define essentially the same function twice: once for constant expressions and once for variables.

To be **constexpr**, a function must be rather simple and cannot have side effects and can only use information passed to it as arguments. In particular, it cannot modify non-local variables, but it can have loops and use its own local variables. For example:

```
constexpr double nth(double x, int n) // assume 0<=n
{
    double res = 1;
    int i = 0;
    while (i<n) { // while-loop: do while the condition is true (§1.7.1)
        res*=x;
        ++i;
    }
    return res;
}
```

In a few places, constant expressions are required by language rules (e.g., array bounds (§1.7), case labels (§1.8), template value arguments (§6.2), and constants declared using **constexpr**). In other cases, compile-time evaluation is important for performance. Independently of performance issues, the notion of immutability (an object with an unchangeable state) is an important design concern.

1.7 Pointers, Arrays, and References

The most fundamental collection of data is a contiguously allocated sequence of elements of the same type, called an *array*. This is basically what the hardware offers. An array of elements of type `char` can be declared like this:

```
char v[6];           // array of 6 characters
```

Similarly, a pointer can be declared like this:

```
char* p;           // pointer to character
```

In declarations, `[]` means “array of” and `*` means “pointer to.” All arrays have `0` as their lower bound, so `v` has six elements, `v[0]` to `v[5]`. The size of an array must be a constant expression (§1.6). A pointer variable can hold the address of an object of the appropriate type:

```
char* p = &v[3];    // p points to v's fourth element
char x = *p;        // *p is the object that p points to
```

In an expression, prefix unary `*` means “contents of” and prefix unary `&` means “address of.” We can represent the result of that initialized definition graphically:

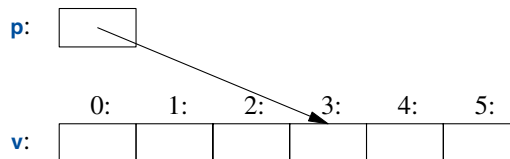

Consider copying ten elements from one array to another:

```
void copy_fct()
{
    int v1[10] = {0,1,2,3,4,5,6,7,8,9};
    int v2[10];           // to become a copy of v1

    for (auto i=0; i!=10; ++i) // copy elements
        v2[i]=v1[i];
    // ...
}
```

This `for`-statement can be read as “set `i` to zero; while `i` is not `10`, copy the `i`th element and increment `i`.” When applied to an integer or floating-point variable, the increment operator, `++`, simply adds `1`. C++ also offers a simpler `for`-statement, called a range-`for`-statement, for loops that traverse a sequence in the simplest way:

```

void print()
{
    int v[] = {0,1,2,3,4,5,6,7,8,9};

    for (auto x : v)           // for each x in v
        cout << x << '\n';

    for (auto x : {10,21,32,43,54,65})
        cout << x << '\n';
    // ...
}

```

The first range-**for**-statement can be read as “for every element of **v**, from the first to the last, place a copy in **x** and print it.” Note that we don’t have to specify an array bound when we initialize it with a list. The range-**for**-statement can be used for any sequence of elements (§12.1).

If we didn’t want to copy the values from **v** into the variable **x**, but rather just have **x** refer to an element, we could write:

```

void increment()
{
    int v[] = {0,1,2,3,4,5,6,7,8,9};

    for (auto& x : v)         // add 1 to each x in v
        ++x;
    // ...
}

```

In a declaration, the unary suffix **&** means “reference to.” A reference is similar to a pointer, except that you don’t need to use a prefix ***** to access the value referred to by the reference. Also, a reference cannot be made to refer to a different object after its initialization.

References are particularly useful for specifying function arguments. For example:

```

void sort(vector<double>& v);    // sort v (v is a vector of doubles)

```

By using a reference, we ensure that for a call **sort(my_vec)**, we do not copy **my_vec** and that it really is **my_vec** that is sorted and not a copy of it.

When we don’t want to modify an argument but still don’t want the cost of copying, we use a **const** reference (§1.6). For example:

```

double sum(const vector<double>&)

```

Functions taking **const** references are very common.

When used in declarations, operators (such as **&**, *****, and **[]**) are called *declarator operators*:

```

T a[n]    // T[n]: a is an array of n Ts
T* p     // T*: p is a pointer to T
T& r     // T&: r is a reference to T
T f(A)   // T(A): f is a function taking an argument of type A returning a result of type T

```

1.7.1 The Null Pointer

We try to ensure that a pointer always points to an object so that dereferencing it is valid. When we don't have an object to point to or if we need to represent the notion of "no object available" (e.g., for an end of a list), we give the pointer the value `nullptr` ("the null pointer"). There is only one `nullptr` shared by all pointer types:

```
double* pd = nullptr;
Link<Record*> lst = nullptr; // pointer to a Link to a Record
int x = nullptr;           // error: nullptr is a pointer not an integer
```

It is often wise to check that a pointer argument actually points to something:

```
int count_x(const char* p, char x)
    // count the number of occurrences of x in p[]
    // p is assumed to point to a zero-terminated array of char (or to nothing)
{
    if (p==nullptr)
        return 0;
    int count = 0;
    for (; *p!=0; ++p)
        if (*p==x)
            ++count;
    return count;
}
```

Note how we can advance a pointer to point to the next element of an array using `++` and that we can leave out the initializer in a `for`-statement if we don't need it.

The definition of `count_x()` assumes that the `char*` is a *C-style string*, that is, that the pointer points to a zero-terminated array of `char`. The characters in a string literal are immutable, so to handle `count_x("Hello!")`, I declared `count_x()` a `const char*` argument.

In older code, `0` or `NULL` is typically used instead of `nullptr`. However, using `nullptr` eliminates potential confusion between integers (such as `0` or `NULL`) and pointers (such as `nullptr`).

In the `count_x()` example, we are not using the initializer part of the `for`-statement, so we can use the simpler `while`-statement:

```
int count_x(const char* p, char x)
    // count the number of occurrences of x in p[]
    // p is assumed to point to a zero-terminated array of char (or to nothing)
{
    if (p==nullptr)
        return 0;
    int count = 0;
    while (*p) {
        if (*p==x)
            ++count;
        ++p;
    }
    return count;
}
```

The **while**-statement executes until its condition becomes **false**.

A test of a numeric value (e.g., **while (*p)** in **count_x()**) is equivalent to comparing the value to **0** (e.g., **while (*p!=0)**). A test of a pointer value (e.g., **if (p)**) is equivalent to comparing the value to **nullptr** (e.g., **if (p!=nullptr)**).

There is no “null reference.” A reference must refer to a valid object (and implementations assume that it does). There are obscure and clever ways to violate that rule; don’t do that.

1.8 Tests

C++ provides a conventional set of statements for expressing selection and looping, such as **if**-statements, **switch**-statements, **while**-loops, and **for**-loops. For example, here is a simple function that prompts the user and returns a Boolean indicating the response:

```
bool accept()
{
    cout << "Do you want to proceed (y or n)?\n";    // write question
    char answer = 0;                                // initialize to a value that will not appear on input
    cin >> answer;                                  // read answer

    if (answer == 'y')
        return true;
    return false;
}
```

To match the **<<** output operator (“put to”), the **>>** operator (“get from”) is used for input; **cin** is the standard input stream (Chapter 10). The type of the right-hand operand of **>>** determines what input is accepted, and its right-hand operand is the target of the input operation. The **\n** character at the end of the output string represents a newline (§1.2.1).

Note that the definition of **answer** appears where it is needed (and not before that). A declaration can appear anywhere a statement can.

The example could be improved by taking an **n** (for “no”) answer into account:

```
bool accept2()
{
    cout << "Do you want to proceed (y or n)?\n";    // write question
    char answer = 0;                                // initialize to a value that will not appear on input
    cin >> answer;                                  // read answer

    switch (answer) {
    case 'y':
        return true;
    case 'n':
        return false;
    default:
        cout << "I'll take that for a no.\n";
        return false;
    }
}
```

A **switch**-statement tests a value against a set of constants. Those constants, called **case**-labels, must be distinct, and if the value tested does not match any of them, the **default** is chosen. If the value doesn't match any **case**-label and no **default** is provided, no action is taken .

We don't have to exit a **case** by returning from the function that contains its **switch**-statement. Often, we just want to continue execution with the statement following the **switch**-statement. We can do that using a **break** statement. As an example, consider an overly clever, yet primitive, parser for a trivial command video game:

```
void action()
{
    while (true) {
        cout << "enter action:\n";           // request action
        string act;
        cin >> act;                          // read characters into a string
        Point delta {0,0};                   // Point holds an {x,y} pair

        for (char ch : act) {
            switch (ch) {
                case 'u': // up
                    ++delta.y;
                    break;
                case 'r': // right
                case 'e': // east
                    ++delta.x;
                    break;
                // ... more actions ...
                default:
                    cout << "I freeze!\n";
            }
            move(current+delta*scale);
            update_display();
        }
    }
}
```

Like a **for**-statement (§1.7), an **if**-statement can introduce a variable and test it. For example:

```
void do_something(vector<int>& v)
{
    if (auto n = v.size(); n!=0) {
        // ... we get here if n!=0 ...
    }
    // ...
}
```

Here, the integer **n** is defined for use within the **if**-statement , initialized with **v.size()**, and immediately tested by the **n!=0** condition after the semicolon. A name declared in a condition is in scope on both branches of the **if**-statement.

As with the `for`-statement, the purpose of declaring a name in the condition of an `if`-statement is to keep the scope of the variable limited to improve readability and minimize errors.

The most common case is testing a variable against `0` (or the `nullptr`). To do that, simply leave out the explicit mention of the condition. For example:

```
void do_something(vector<int>& v)
{
    if (auto n = v.size()) {
        // ... we get here if n!=0 ...
    }
    // ...
}
```

Prefer to use this terser and simpler form when you can.

1.9 Mapping to Hardware

C++ offers a direct mapping to hardware. When you use one of the fundamental operations, the implementation is what the hardware offers, typically a single machine operation. For example, adding two `ints`, `x+y` executes an integer add machine instruction.

A C++ implementation sees a machine's memory as a sequence of memory locations into which it can place (typed) objects and address them using pointers:

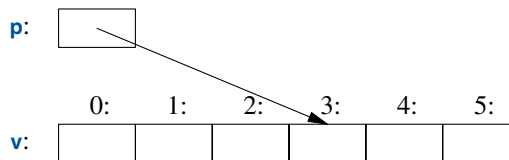

A pointer is represented in memory as a machine address, so the numeric value of `p` in this figure would be `3`. If this looks much like an array (§1.7), that's because an array is C++'s basic abstraction of “a contiguous sequence of objects in memory.”

The simple mapping of fundamental language constructs to hardware is crucial for the raw low-level performance for which C and C++ have been famous for decades. The basic machine model of C and C++ is based on computer hardware, rather than some form of mathematics.

1.9.1 Assignment

An assignment of a built-in type is a simple machine copy operation. Consider:

```
int x = 2;
int y = 3;
x = y;           // x becomes 3
// Note: x==y
```

This is obvious. We can graphically represent that like this:

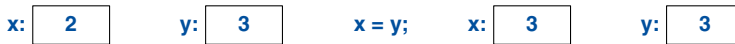

Note that the two objects are independent. We can change the value of **y** without affecting the value of **x**. For example **x=99** will not change the value of **y**. Unlike Java, C#, and other languages, but like C, that is true for all types, not just for **ints**.

If we want different objects to refer to the same (shared) value, we must say so. We could use pointers:

```
int x = 2;
int y = 3;
int* p = &x;
int* q = &y; // now p!=q and *p!=*q
p = q;      // p becomes &y; now p==q, so (obviously)*p == *q
```

We can represent that graphically like this:

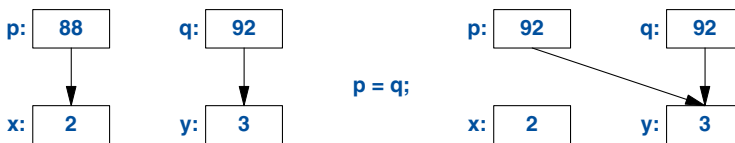

I arbitrarily chose **88** and **92** as the addresses of the **ints**. Again, we can see that the assigned-to object gets the value from the assigned object, yielding two independent objects (here, pointers), with the same value. That is, **p=q** gives **p==q**. After **p=q**, both pointers point to **y**.

A reference and a pointer both refer/point to an object and both are represented in memory as a machine address. However, the language rules for using them differ. Assignment to a reference does not change what the reference refers to but assigns to the referenced object:

```
int x = 2;
int y = 3;
int& r = x; // r refers to x
int& r2 = y; // now r2 refers to y
r = r2;     // read through r2, write through r: x becomes 3
```

We can represent that graphically like this:

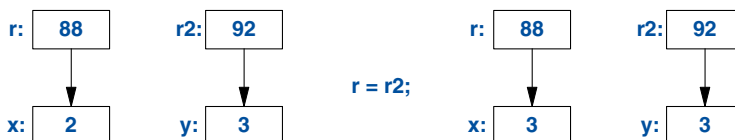

To access the value pointed to by a pointer, you use *****; that is automatically (implicitly) done for a reference.

After **x=y**, we have **x==y** for every built-in type and well-designed user-defined type (Chapter 2) that offers **=** (assignment) and **==** (equality comparison).

1.9.2 Initialization

Initialization differs from assignment. In general, for an assignment to work correctly, the assigned-to object must have a value. On the other hand, the task of initialization is to make an uninitialized piece of memory into a valid object. For almost all types, the effect of reading from or writing to an uninitialized variable is undefined. For built-in types, that's most obvious for references:

```
int x = 7;
int& r {x};    // bind r to x (r refers to x)
r = 7;        // assign to whatever r refers to

int& r2;      // error: uninitialized reference
r2 = 99;     // assign to whatever r2 refers to
```

Fortunately, we cannot have an uninitialized reference; if we could, then that `r2=99` would assign `99` to some unspecified memory location; the result would eventually lead to bad results or a crash.

You can use `=` to initialize a reference but please don't let that confuse you. For example:

```
int& r = x;    // bind r to x (r refers to x)
```

This is still initialization and binds `r` to `x`, rather than any form of value copy.

The distinction between initialization and assignment is also crucial to many user-defined types, such as `string` and `vector`, where an assigned-to object owns a resource that needs to eventually be released (§5.3).

The basic semantics of argument passing and function value return are that of initialization (§3.6). For example, that's how we get pass-by-reference.

1.10 Advice

The advice here is a subset of the C++ Core Guidelines [Stroustrup,2015]. References to guidelines look like this [CG: ES.23], meaning the 23rd rule in the Expressions and Statement section. Generally, a core guideline offers further rationale and examples.

- [1] Don't panic! All will become clear in time; §1.1; [CG: In.0].
- [2] Don't use the built-in features exclusively or on their own. On the contrary, the fundamental (built-in) features are usually best used indirectly through libraries, such as the ISO C++ standard library (Chapters 8–15); [CG: P.10].
- [3] You don't have to know every detail of C++ to write good programs.
- [4] Focus on programming techniques, not on language features.
- [5] For the final word on language definition issues, see the ISO C++ standard; §16.1.3; [CG: P.2].
- [6] “Package” meaningful operations as carefully named functions; §1.3; [CG: F.1].
- [7] A function should perform a single logical operation; §1.3 [CG: F.2].
- [8] Keep functions short; §1.3; [CG: F.3].
- [9] Use overloading when functions perform conceptually the same task on different types; §1.3.
- [10] If a function may have to be evaluated at compile time, declare it `constexpr`; §1.6; [CG: F.4].

- [11] Understand how language primitives map to hardware; §1.4, §1.7, §1.9, §2.3, §4.2.2, §4.4.
- [12] Use digit separators to make large literals readable; §1.4; [CG: NL.11].
- [13] Avoid complicated expressions; [CG: ES.40].
- [14] Avoid narrowing conversions; §1.4.2; [CG: ES.46].
- [15] Minimize the scope of a variable; §1.5.
- [16] Avoid “magic constants”; use symbolic constants; §1.6; [CG: ES.45].
- [17] Prefer immutable data; §1.6; [CG: P.10].
- [18] Declare one name (only) per declaration; [CG: ES.10].
- [19] Keep common and local names short, and keep uncommon and nonlocal names longer; [CG: ES.7].
- [20] Avoid similar-looking names; [CG: ES.8].
- [21] Avoid **ALL_CAPS** names; [CG: ES.9].
- [22] Prefer the `{}`-initializer syntax for declarations with a named type; §1.4; [CG: ES.23].
- [23] Use **auto** to avoid repeating type names; §1.4.2; [CG: ES.11].
- [24] Avoid uninitialized variables; §1.4; [CG: ES.20].
- [25] Keep scopes small; §1.5; [CG: ES.5].
- [26] When declaring a variable in the condition of an **if**-statement, prefer the version with the implicit test against **0**; §1.8.
- [27] Use **unsigned** for bit manipulation only; §1.4; [CG: ES.101] [CG: ES.106].
- [28] Keep use of pointers simple and straightforward; §1.7; [CG: ES.42].
- [29] Use **nullptr** rather than **0** or **NULL**; §1.7; [CG: ES.47].
- [30] Don't declare a variable until you have a value to initialize it with; §1.7, §1.8; [CG: ES.21].
- [31] Don't say in comments what can be clearly stated in code; [CG: NL.1].
- [32] State intent in comments; [CG: NL.2].
- [33] Maintain a consistent indentation style; [CG: NL.4].

This page intentionally left blank

User-Defined Types

Don't Panic!
– Douglas Adams

- Introduction
- Structures
- Classes
- Unions
- Enumerations
- Advice

2.1 Introduction

We call the types that can be built from the fundamental types (§1.4), the `const` modifier (§1.6), and the declarator operators (§1.7) *built-in types*. C++'s set of built-in types and operations is rich, but deliberately low-level. They directly and efficiently reflect the capabilities of conventional computer hardware. However, they don't provide the programmer with high-level facilities to conveniently write advanced applications. Instead, C++ augments the built-in types and operations with a sophisticated set of *abstraction mechanisms* out of which programmers can build such high-level facilities.

The C++ abstraction mechanisms are primarily designed to let programmers design and implement their own types, with suitable representations and operations, and for programmers to simply and elegantly use such types. Types built out of other types using C++'s abstraction mechanisms are called *user-defined types*. They are referred to as *classes* and *enumerations*. User defined types can be built out of both built-in types and other user-defined types. Most of this book is devoted to the design, implementation, and use of user-defined types. User-defined types are often preferred over built-in types because they are easier to use, less error-prone, and typically as efficient for what they do as direct use of built-in types, or even faster.

The rest of this chapter presents the simplest and most fundamental facilities for defining and using types. Chapters 4–7 are a more complete description of the abstraction mechanisms and the programming styles they support. Chapters 8–15 present an overview of the standard library, and since the standard library mainly consists of user-defined types, they provide examples of what can be built using the language facilities and programming techniques presented in Chapters 1–7.

2.2 Structures

The first step in building a new type is often to organize the elements it needs into a data structure, a **struct**:

```
struct Vector {
    int sz;           // number of elements
    double* elem;    // pointer to elements
};
```

This first version of **Vector** consists of an **int** and a **double***.

A variable of type **Vector** can be defined like this:

```
Vector v;
```

However, by itself that is not of much use because **v**'s **elem** pointer doesn't point to anything. For it to be useful, we must give **v** some elements to point to. For example, we can construct a **Vector** like this:

```
void vector_init(Vector& v, int s)
{
    v.elem = new double[s]; // allocate an array of s doubles
    v.sz = s;
}
```

That is, **v**'s **elem** member gets a pointer produced by the **new** operator and **v**'s **sz** member gets the number of elements. The **&** in **Vector&** indicates that we pass **v** by non-**const** reference (§1.7); that way, **vector_init()** can modify the vector passed to it.

The **new** operator allocates memory from an area called the *free store* (also known as *dynamic memory* and *heap*). Objects allocated on the free store are independent of the scope from which they are created and “live” until they are destroyed using the **delete** operator (§4.2.2).

A simple use of **Vector** looks like this:

```
double read_and_sum(int s)
    // read s integers from cin and return their sum; s is assumed to be positive
{
    Vector v;
    vector_init(v,s);           // allocate s elements for v

    for (int i=0; i!=s; ++i)
        cin>>v.elem[i];       // read into elements
}
```

```

double sum = 0;
for (int i=0; i!=s; ++i)
    sum+=v.elem[i];           // compute the sum of the elements
return sum;
}

```

There is a long way to go before our **Vector** is as elegant and flexible as the standard-library **vector**. In particular, a user of **Vector** has to know every detail of **Vector**'s representation. The rest of this chapter and the next two gradually improve **Vector** as an example of language features and techniques. Chapter 11 presents the standard-library **vector**, which contains many nice improvements.

I use **vector** and other standard-library components as examples

- to illustrate language features and design techniques, and
- to help you learn and use the standard-library components.

Don't reinvent standard-library components such as **vector** and **string**; use them.

We use **.** (dot) to access **struct** members through a name (and through a reference) and **->** to access **struct** members through a pointer. For example:

```

void f(Vector v, Vector& rv, Vector* pv)
{
    int i1 = v.sz;           // access through name
    int i2 = rv.sz;         // access through reference
    int i3 = pv->sz;        // access through pointer
}

```

2.3 Classes

Having the data specified separately from the operations on it has advantages, such as the ability to use the data in arbitrary ways. However, a tighter connection between the representation and the operations is needed for a user-defined type to have all the properties expected of a "real type." In particular, we often want to keep the representation inaccessible to users so as to ease use, guarantee consistent use of the data, and allow us to later improve the representation. To do that we have to distinguish between the interface to a type (to be used by all) and its implementation (which has access to the otherwise inaccessible data). The language mechanism for that is called a *class*. A class has a set of *members*, which can be data, function, or type members. The interface is defined by the **public** members of a class, and **private** members are accessible only through that interface. For example:

```

class Vector {
public:
    Vector(int s) :elem{new double[s]}, sz{s} { } // construct a Vector
    double& operator[](int i) { return elem[i]; } // element access: subscripting
    int size() { return sz; }
private:
    double* elem; // pointer to the elements
    int sz;       // the number of elements
};

```

Given that, we can define a variable of our new type **Vector**:

```
Vector v(6); // a Vector with 6 elements
```

We can illustrate a **Vector** object graphically:

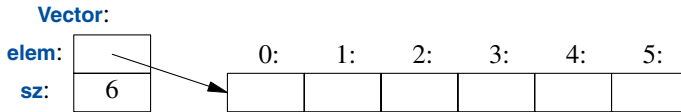

Basically, the **Vector** object is a “handle” containing a pointer to the elements (**elem**) and the number of elements (**sz**). The number of elements (6 in the example) can vary from **Vector** object to **Vector** object, and a **Vector** object can have a different number of elements at different times (§4.2.3). However, the **Vector** object itself is always the same size. This is the basic technique for handling varying amounts of information in C++: a fixed-size handle referring to a variable amount of data “elsewhere” (e.g., on the free store allocated by **new**; §4.2.2). How to design and use such objects is the main topic of Chapter 4.

Here, the representation of a **Vector** (the members **elem** and **sz**) is accessible only through the interface provided by the **public** members: **Vector()**, **operator[]()**, and **size()**. The **read_and_sum()** example from §2.2 simplifies to:

```
double read_and_sum(int s)
{
    Vector v(s); // make a vector of s elements
    for (int i=0; i!=v.size(); ++i)
        cin>>v[i]; // read into elements

    double sum = 0;
    for (int i=0; i!=v.size(); ++i)
        sum+=v[i]; // take the sum of the elements
    return sum;
}
```

A member “function” with the same name as its class is called a *constructor*, that is, a function used to construct objects of a class. So, the constructor, **Vector()**, replaces **vector_init()** from §2.2. Unlike an ordinary function, a constructor is guaranteed to be used to initialize objects of its class. Thus, defining a constructor eliminates the problem of uninitialized variables for a class.

Vector(int) defines how objects of type **Vector** are constructed. In particular, it states that it needs an integer to do that. That integer is used as the number of elements. The constructor initializes the **Vector** members using a member initializer list:

```
:elem{new double[s]}, sz{s}
```

That is, we first initialize **elem** with a pointer to **s** elements of type **double** obtained from the free store. Then, we initialize **sz** to **s**.

Access to elements is provided by a subscript function, called **operator[]**. It returns a reference to the appropriate element (a **double&** allowing both reading and writing).

The `size()` function is supplied to give users the number of elements.

Obviously, error handling is completely missing, but we'll return to that in §3.5. Similarly, we did not provide a mechanism to “give back” the array of `doubles` acquired by `new`; §4.2.2 shows how to use a destructor to elegantly do that.

There is no fundamental difference between a `struct` and a `class`; a `struct` is simply a `class` with members `public` by default. For example, you can define constructors and other member functions for a `struct`.

2.4 Unions

A `union` is a `struct` in which all members are allocated at the same address so that the `union` occupies only as much space as its largest member. Naturally, a `union` can hold a value for only one member at a time. For example, consider a symbol table entry that holds a name and a value. The value can either be a `Node*` or an `int`:

```
enum Type { ptr, num }; // a Type can hold values ptr and num (§2.5)
```

```
struct Entry {
    string name; // string is a standard-library type
    Type t;
    Node* p; // use p if t==ptr
    int i; // use i if t==num
};

void f(Entry* pe)
{
    if (pe->t == num)
        cout << pe->i;
    // ...
}
```

The members `p` and `i` are never used at the same time, so space is wasted. It can be easily recovered by specifying that both should be members of a `union`, like this:

```
union Value {
    Node* p;
    int i;
};
```

The language doesn't keep track of which kind of value is held by a `union`, so the programmer must do that:

```
struct Entry {
    string name;
    Type t;
    Value v; // use v.p if t==ptr; use v.i if t==num
};
```

```

void f(Entry* pe)
{
    if (pe->t == num)
        cout << pe->v.i;
    // ...
}

```

Maintaining the correspondence between a *type field* (here, `t`) and the type held in a `union` is error-prone. To avoid errors, we can enforce that correspondence by encapsulating the union and the type field in a class and offer access only through member functions that use the union correctly. At the application level, abstractions relying on such *tagged unions* are common and useful. The use of “naked” `unions` is best minimized.

The standard library type, `variant`, can be used to eliminate most direct uses of unions. A `variant` stores a value of one of a set of alternative types (§13.5.1). For example, a `variant<Node*,int>` can hold either a `Node*` or an `int`.

Using `variant`, the `Entry` example could be written as:

```

struct Entry {
    string name;
    variant<Node*,int> v;
};

void f(Entry* pe)
{
    if (holds_alternative<int>(pe->v)) // does *pe hold an int? (see §13.5.1)
        cout << get<int>(pe->v);    // get the int
    // ...
}

```

For many uses, a `variant` is simpler and safer to use than a `union`.

2.5 Enumerations

In addition to classes, C++ supports a simple form of user-defined type for which we can enumerate the values:

```

enum class Color { red, blue, green };
enum class Traffic_light { green, yellow, red };

```

```

Color col = Color::red;
Traffic_light light = Traffic_light::red;

```

Note that enumerators (e.g., `red`) are in the scope of their `enum class`, so that they can be used repeatedly in different `enum classes` without confusion. For example, `Color::red` is `Color`'s `red` which is different from `Traffic_light::red`.

Enumerations are used to represent small sets of integer values. They are used to make code more readable and less error-prone than it would have been had the symbolic (and mnemonic) enumerator names not been used.

The **class** after the **enum** specifies that an enumeration is strongly typed and that its enumerators are scoped. Being separate types, **enum classes** help prevent accidental misuses of constants. In particular, we cannot mix **Traffic_light** and **Color** values:

```
Color x = red;           // error: which red?
Color y = Traffic_light::red; // error: that red is not a Color
Color z = Color::red;   // OK
```

Similarly, we cannot implicitly mix **Color** and integer values:

```
int i = Color::red;     // error: Color::red is not an int

Color c = 2;           // initialization error: 2 is not a Color
```

Catching attempted conversions to an enum is a good defense against errors, but often we want to initialize an enum with a value from its underlying type (by default, that's **int**), so that's allowed, as is explicit conversion from the underlying type:

```
Color x = Color{5}; // OK, but verbose
Color y {6};       // also OK
```

By default, an **enum class** has only assignment, initialization, and comparisons (e.g., **==** and **<**; §1.4) defined. However, an enumeration is a user-defined type, so we can define operators for it:

```
Traffic_light& operator++(Traffic_light& t) // prefix increment: ++
{
    switch (t) {
        case Traffic_light::green: return t=Traffic_light::yellow;
        case Traffic_light::yellow: return t=Traffic_light::red;
        case Traffic_light::red:    return t=Traffic_light::green;
    }
}

Traffic_light next = ++light; // next becomes Traffic_light::green
```

If you don't want to explicitly qualify enumerator names and want enumerator values to be **ints** (without the need for an explicit conversion), you can remove the **class** from **enum class** to get a "plain" **enum**. The enumerators from a "plain" **enum** are entered into the same scope as the name of their **enum** and implicitly converts to their integer value. For example:

```
enum Color { red, green, blue };
int col = green;
```

Here **col** gets the value **1**. By default, the integer values of enumerators start with **0** and increase by one for each additional enumerator. The "plain" **enums** have been in C++ (and C) since the earliest days, so even though they are less well behaved, they are common in current code.

2.6 Advice

- [1] Prefer well-defined user-defined types over built-in types when the built-in types are too low-level; §2.1.

- [2] Organize related data into structures (**structs** or **classes**); §2.2; [CG: C.1].
- [3] Represent the distinction between an interface and an implementation using a **class**; §2.3; [CG: C.3].
- [4] A **struct** is simply a **class** with its members **public** by default; §2.3.
- [5] Define constructors to guarantee and simplify initialization of **classes**; §2.3; [CG: C.2].
- [6] Avoid “naked” **unions**; wrap them in a class together with a type field; §2.4; [CG: C.181].
- [7] Use enumerations to represent sets of named constants; §2.5; [CG: Enum.2].
- [8] Prefer **class enums** over “plain” **enums** to minimize surprises; §2.5; [CG: Enum.3].
- [9] Define operations on enumerations for safe and simple use; §2.5; [CG: Enum.4].

Modularity

Don't interrupt me while I'm interrupting.
– Winston S. Churchill

- Introduction
- Separate Compilation
- Modules
- Namespaces
- Error Handling
 - Exceptions; Invariants; Error-Handling Alternatives; Contracts; Static Assertions
- Function Arguments and Return Values
 - Argument Passing; Value Return; Structured Binding
- Advice

3.1 Introduction

A C++ program consists of many separately developed parts, such as functions (§1.2.1), user-defined types (Chapter 2), class hierarchies (§4.5), and templates (Chapter 6). The key to managing this is to clearly define the interactions among those parts. The first and most important step is to distinguish between the interface to a part and its implementation. At the language level, C++ represents interfaces by declarations. A *declaration* specifies all that's needed to use a function or a type. For example:

```
double sqrt(double);    // the square root function takes a double and returns a double
```

```
class Vector {  
public:  
    Vector(int s);  
    double& operator[](int i);  
    int size();
```

```
private:
    double* elem; // elem points to an array of sz doubles
    int sz;
};
```

The key point here is that the function bodies, the function *definitions*, are “elsewhere.” For this example, we might like for the representation of **Vector** to be “elsewhere” also, but we will deal with that later (abstract types; §4.3). The definition of **sqrt()** will look like this:

```
double sqrt(double d)           // definition of sqrt()
{
    // ... algorithm as found in math textbook ...
}
```

For **Vector**, we need to define all three member functions:

```
Vector::Vector(int s)           // definition of the constructor
    :elem{new double[s]}, sz{s} // initialize members
{
}

double& Vector::operator[](int i) // definition of subscripting
{
    return elem[i];
}

int Vector::size()              // definition of size()
{
    return sz;
}
```

We must define **Vector**’s functions, but not **sqrt()** because it is part of the standard library. However, that makes no real difference: a library is simply “some other code we happen to use” written with the same language facilities we use.

There can be many declarations for an entity, such as a function, but only one definition.

3.2 Separate Compilation

C++ supports a notion of separate compilation where user code sees only declarations of the types and functions used. The definitions of those types and functions are in separate source files and are compiled separately. This can be used to organize a program into a set of semi-independent code fragments. Such separation can be used to minimize compilation times and to strictly enforce separation of logically distinct parts of a program (thus minimizing the chance of errors). A library is often a collection of separately compiled code fragments (e.g., functions).

Typically, we place the declarations that specify the interface to a module in a file with a name indicating its intended use. For example:

```
// Vector.h:

class Vector {
public:
    Vector(int s);
    double& operator[](int i);
    int size();
private:
    double* elem;    // elem points to an array of sz doubles
    int sz;
};
```

This declaration would be placed in a file **Vector.h**. Users then *include* that file, called a *header file*, to access that interface. For example:

```
// user.cpp:

#include "Vector.h"    // get Vector's interface
#include <cmath>       // get the standard-library math function interface including sqrt()

double sqrt_sum(Vector& v)
{
    double sum = 0;
    for (int i=0; i<v.size(); ++i)
        sum+=std::sqrt(v[i]);    // sum of square roots
    return sum;
}
```

To help the compiler ensure consistency, the **.cpp** file providing the implementation of **Vector** will also include the **.h** file providing its interface:

```
// Vector.cpp:

#include "Vector.h" // get Vector's interface

Vector::Vector(int s)
    :elem(new double[s]), sz{s}    // initialize members
{
}

double& Vector::operator[](int i)
{
    return elem[i];
}

int Vector::size()
{
    return sz;
}
```

The code in **user.cpp** and **Vector.cpp** shares the **Vector** interface information presented in **Vector.h**,

but the two files are otherwise independent and can be separately compiled. Graphically, the program fragments can be represented like this:

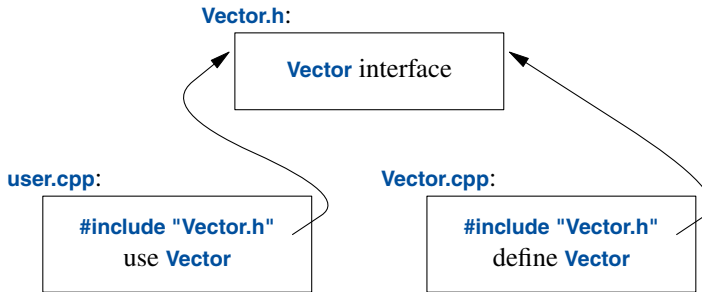

Strictly speaking, using separate compilation isn't a language issue; it is an issue of how best to take advantage of a particular language implementation. However, it is of great practical importance. The best approach to program organization is to think of the program as a set of modules with well-defined dependencies, represent that modularity logically through language features, and then exploit the modularity physically through files for effective separate compilation.

A `.cpp` file that is compiled by itself (including the `h` files it `#includes`) is called a *translation unit*. A program can consist of many thousand translation units.

3.3 Modules (C++20)

The use of `#includes` is a very old, error-prone, and rather expensive way of composing programs out of parts. If you `#include header.h` in 101 translation units, the text of `header.h` will be processed by the compiler 101 times. If you `#include header1.h` before `header2.h` the declarations and macros in `header1.h` might affect the meaning of the code in `header2.h`. If instead you `#include header2.h` before `header1.h`, it is `header2.h` that might affect the code in `header1.h`. Obviously, this is not ideal, and in fact it has been a major source of cost and bugs since 1972 when this mechanism was first introduced into C.

We are finally about to get a better way of expressing physical modules in C++. The language feature, called `modules` is not yet ISO C++, but it is an ISO Technical Specification [ModulesTS] and will be part of C++20. Implementations are in use, so I risk recommending it here even though details are likely to change and it may be years before everybody can use it in production code. Old code, in this case code using `#include`, can “live” for a very long time because it can be costly and time consuming to update.

Consider how to express the `Vector` and `sqrt_sum()` example from §3.2 using `modules`:

```
// file Vector.cpp:
```

```
module; // this compilation will define a module
```

```
// ... here we put stuff that Vector might need for its implementation ...
```

```

export module Vector;    // defining the module called "Vector"

export class Vector {
public:
    Vector(int s);
    double& operator[](int i);
    int size();
private:
    double* elem;        // elem points to an array of sz doubles
    int sz;
};

Vector::Vector(int s)
    :elem{new double[s]}, sz{s}    // initialize members
{
}

double& Vector::operator[](int i)
{
    return elem[i];
}

int Vector::size()
{
    return sz;
}

export int size(const Vector& v) { return v.size(); }

```

This defines a **module** called **Vector**, which exports the class **Vector**, all its member functions, and the non-member function **size()**.

The way we use this **module** is to **import** it where we need it. For example:

// file user.cpp:

```

import Vector;          // get Vector's interface
#include <cmath>         // get the standard-library math function interface including sqrt()

double sqrt_sum(Vector& v)
{
    double sum = 0;
    for (int i=0; i!=v.size(); ++i)
        sum+=std::sqrt(v[i]);    // sum of square roots
    return sum;
}

```

I could have **imported** the standard library mathematical functions also, but I used the old-fashioned **#include** just to show that you can mix old and new. Such mixing is essential for gradually upgrading older code from using **#include** to **import**.

The differences between headers and modules are not just syntactic.

- A module is compiled once only (rather than in each translation unit in which it is used).
- Two modules can be **imported** in either order without changing their meaning.
- If you import something into a module, users of your module do not implicitly gain access to (and are not bothered by) what you imported: **import** is not transitive.

The effects on maintainability and compile-time performance can be spectacular.

3.4 Namespaces

In addition to functions (§1.3), classes (§2.3), and enumerations (§2.5), C++ offers *namespaces* as a mechanism for expressing that some declarations belong together and that their names shouldn't clash with other names. For example, I might want to experiment with my own complex number type (§4.2.1, §14.4):

```
namespace My_code {
    class complex {
        // ...
    };

    complex sqrt(complex);
    // ...

    int main();
}

int My_code::main()
{
    complex z {1,2};
    auto z2 = sqrt(z);
    std::cout << '{' << z2.real() << ',' << z2.imag() << "}" << "\n";
    // ...
}

int main()
{
    return My_code::main();
}
```

By putting my code into the namespace **My_code**, I make sure that my names do not conflict with the standard-library names in namespace **std** (§3.4). That precaution is wise, because the standard library does provide support for **complex** arithmetic (§4.2.1, §14.4).

The simplest way to access a name in another namespace is to qualify it with the namespace name (e.g., **std::cout** and **My_code::main**). The “real **main()**” is defined in the global namespace, that is, not local to a defined namespace, class, or function.

If repeatedly qualifying a name becomes tedious or distracting, we can bring the name into a scope with a **using**-declaration:

```

void my_code(vector<int>& x, vector<int>& y)
{
    using std::swap;           // use the standard-library swap
    // ...
    swap(x,y);                // std::swap()
    other::swap(x,y);         // some other swap()
    // ...
}

```

A **using**-declaration makes a name from a namespace usable as if it was declared in the scope in which it appears. After **using std::swap**, it is exactly as if **swap** had been declared in **my_code()**.

To gain access to all names in the standard-library namespace, we can use a **using**-directive:

```
using namespace std;
```

A **using**-directive makes unqualified names from the named namespace accessible from the scope in which we placed the directive. So after the **using**-directive for **std**, we can simply write **cout** rather than **std::cout**. By using a **using**-directive, we lose the ability to selectively use names from that namespace, so this facility should be used carefully, usually for a library that's pervasive in an application (e.g., **std**) or during a transition for an application that didn't use **namespaces**.

Namespaces are primarily used to organize larger program components, such as libraries. They simplify the composition of a program out of separately developed parts.

3.5 Error Handling

Error handling is a large and complex topic with concerns and ramifications that go far beyond language facilities into programming techniques and tools. However, C++ provides a few features to help. The major tool is the type system itself. Instead of painstakingly building up our applications from the built-in types (e.g., **char**, **int**, and **double**) and statements (e.g., **if**, **while**, and **for**), we build types (e.g., **string**, **map**, and **regex**) and algorithms (e.g., **sort()**, **find_if()**, and **draw_all()**) that are appropriate for our applications. Such higher-level constructs simplify our programming, limit our opportunities for mistakes (e.g., you are unlikely to try to apply a tree traversal to a dialog box), and increase the compiler's chances of catching errors. The majority of C++ language constructs are dedicated to the design and implementation of elegant and efficient abstractions (e.g., user-defined types and algorithms using them). One effect of such abstraction is that the point where a run-time error can be detected is separated from the point where it can be handled. As programs grow, and especially when libraries are used extensively, standards for handling errors become important. It is a good idea to articulate a strategy for error handling early on in the development of a program.

3.5.1 Exceptions

Consider again the **Vector** example. What *ought* to be done when we try to access an element that is out of range for the vector from §2.3?

- The writer of **Vector** doesn't know what the user would like to have done in this case (the writer of **Vector** typically doesn't even know in which program the vector will be running).

- The user of `Vector` cannot consistently detect the problem (if the user could, the out-of-range access wouldn't happen in the first place).

Assuming that out-of-range access is a kind of error that we want to recover from, the solution is for the `Vector` implementer to detect the attempted out-of-range access and tell the user about it. The user can then take appropriate action. For example, `Vector::operator[]()` can detect an attempted out-of-range access and throw an `out_of_range` exception:

```
double& Vector::operator[](int i)
{
    if (i<0 || size()<=i)
        throw out_of_range{"Vector::operator[]"};
    return elem[i];
}
```

The `throw` transfers control to a handler for exceptions of type `out_of_range` in some function that directly or indirectly called `Vector::operator[]()`. To do that, the implementation will *unwind* the function call stack as needed to get back to the context of that caller. That is, the exception handling mechanism will exit scopes and functions as needed to get back to a caller that has expressed interest in handling that kind of exception, invoking destructors (§4.2.2) along the way as needed. For example:

```
void f(Vector& v)
{
    // ...
    try { // exceptions here are handled by the handler defined below

        v[v.size()] = 7; // try to access beyond the end of v
    }
    catch (out_of_range& err) { // oops: out_of_range error
        // ... handle range error ...
        cerr << err.what() << '\n';
    }
    // ...
}
```

We put code for which we are interested in handling exceptions into a `try`-block. The attempted assignment to `v[v.size()]` will fail. Therefore, the `catch`-clause providing a handler for exceptions of type `out_of_range` will be entered. The `out_of_range` type is defined in the standard library (in `<stdexcept>`) and is in fact used by some standard-library container access functions.

I caught the exception by reference to avoid copying and used the `what()` function to print the error message put into it at the `throw`-point.

Use of the exception-handling mechanisms can make error handling simpler, more systematic, and more readable. To achieve that, don't overuse `try`-statements. The main technique for making error handling simple and systematic (called *Resource Acquisition Is Initialization*; *RAII*) is explained in §4.2.2. The basic idea behind *RAII* is for a constructor to acquire all resources necessary for a class to operate and have the destructor release all resources, thus making resource release guaranteed and implicit.

A function that should never throw an exception can be declared `noexcept`. For example:

```
void user(int sz) noexcept
{
    Vector v(sz);
    iota(&v[0], &v[sz], 1);    // fill v with 1,2,3,4... (see §14.3)
    // ...
}
```

If all good intent and planning fails, so that `user()` still throws, `std::terminate()` is called to immediately terminate the program.

3.5.2 Invariants

The use of exceptions to signal out-of-range access is an example of a function checking its argument and refusing to act because a basic assumption, a *precondition*, didn't hold. Had we formally specified `Vector`'s subscript operator, we would have said something like "the index must be in the `[0: size())` range," and that was in fact what we tested in our `operator[]()`. The `[a:b)` notation specifies a half-open range, meaning that `a` is part of the range, but `b` is not. Whenever we define a function, we should consider what its preconditions are and consider whether to test them (§3.5.3). For most applications it is a good idea to test simple invariants; see also §3.5.4.

However, `operator[]()` operates on objects of type `Vector` and nothing it does makes any sense unless the members of `Vector` have "reasonable" values. In particular, we did say "`elem` points to an array of `sz` doubles" but we only said that in a comment. Such a statement of what is assumed to be true for a class is called a *class invariant*, or simply an *invariant*. It is the job of a constructor to establish the invariant for its class (so that the member functions can rely on it) and for the member functions to make sure that the invariant holds when they exit. Unfortunately, our `Vector` constructor only partially did its job. It properly initialized the `Vector` members, but it failed to check that the arguments passed to it made sense. Consider:

```
Vector v(-27);
```

This is likely to cause chaos.

Here is a more appropriate definition:

```
Vector::Vector(int s)
{
    if (s < 0)
        throw length_error{"Vector constructor: negative size"};
    elem = new double[s];
    sz = s;
}
```

I use the standard-library exception `length_error` to report a non-positive number of elements because some standard-library operations use that exception to report problems of this kind. If operator `new` can't find memory to allocate, it throws a `std::bad_alloc`. We can now write:

```

void test()
{
    try {
        Vector v(-27);
    }
    catch (std::length_error& err) {
        // handle negative size
    }
    catch (std::bad_alloc& err) {
        // handle memory exhaustion
    }
}

```

You can define your own classes to be used as exceptions and have them carry arbitrary information from a point where an error is detected to a point where it can be handled (§3.5.1).

Often, a function has no way of completing its assigned task after an exception is thrown. Then, “handling” an exception means doing some minimal local cleanup and rethrowing the exception. For example:

```

void test()
{
    try {
        Vector v(-27);
    }
    catch (std::length_error&) { // do something and rethrow
        cerr << "test failed: length error\n";
        throw; // rethrow
    }
    catch (std::bad_alloc&) { // Ouch! this program is not designed to handle memory exhaustion
        std::terminate(); // terminate the program
    }
}

```

In well-designed code **try**-blocks are rare. Avoid overuse by systematically using the RAII technique (§4.2.2, §5.3).

The notion of invariants is central to the design of classes, and preconditions serve a similar role in the design of functions. Invariants

- help us to understand precisely what we want
- force us to be specific; that gives us a better chance of getting our code correct (after debugging and testing).

The notion of invariants underlies C++’s notions of resource management supported by constructors (Chapter 4) and destructors (§4.2.2, §13.2).

3.5.3 Error-Handling Alternatives

Error handling is a major issue in all real-world software, so naturally there are a variety of approaches. If an error is detected and it cannot be handled locally in a function, the function must somehow communicate the problem to some caller. Throwing an exception is C++’s most general mechanism for that.

There are languages where exceptions are designed simply to provide an alternate mechanism for returning values. C++ is not such a language: exceptions are designed to be used to report failure to complete a given task. Exceptions are integrated with constructors and destructors to provide a coherent framework for error handling and resource management (§4.2.2, §5.3). Compilers are optimized to make returning a value much cheaper than throwing the same value as an exception.

Throwing an exception is not the only way of reporting an error that cannot be handled locally. A function can indicate that it cannot perform its allotted task by:

- throwing an exception
- somehow return a value indicating failure
- terminating the program (by invoking a function like `terminate()`, `exit()`, or `abort()`).

We return an error indicator (an “error code”) when:

- A failure is normal and expected. For example, it is quite normal for a request to open a file to fail (maybe there is no file of that name or maybe the file cannot be opened with the permissions requested).
- An immediate caller can reasonably be expected to handle the failure.

We throw an exception when:

- An error is so rare that a programmer is likely to forget to check for it. For example, when did you last check the return value of `printf()`?
- An error cannot be handled by an immediate caller. Instead, the error has to percolate back to an ultimate caller. For example, it is infeasible to have every function in an application reliably handle every allocation failure or network outage.
- New kinds of errors can be added in lower-modules of an application so that higher-level modules are not written to cope with such errors. For example, when a previously single-threaded application is modified to use multiple threads or resources are placed remotely to be accessed over a network.
- No suitable return path for errors codes are available. For example, a constructor does not have a return value for a “caller” to check. In particular, constructors may be invoked for several local variables or in a partially constructed complex object so that clean-up based on error codes would be quite complicated.
- The return path of a function is made more complicated or expensive by a need to pass both a value and an error indicator back (e.g., a `pair`; §13.4.3), possibly leading to the use of out-parameters, non-local error-status indicators, or other workarounds.
- The error has to be transmitted up a call chain to an “ultimate caller.” Repeatedly checking an error-code would be tedious, expensive, and error-prone.
- The recovery from errors depends on the results of several function calls, leading to the need to maintain local state between calls and complicated control structures.
- The function that found the error was a callback (a function argument), so the immediate caller may not even know what function was called.
- An error implies that some “undo action” is needed.

We terminate when

- An error is of a kind from which we cannot recover. For example, for many – but not all – systems there is no reasonable way to recover from memory exhaustion.
- The system is one where error-handling is based on restarting a thread, process, or computer whenever a non-trivial error is detected.

One way to ensure termination is to add `noexcept` to a function so that a `throw` from anywhere in the function's implementation will turn into a `terminate()`. Note that there are applications that can't accept unconditional terminations, so alternatives must be used.

Unfortunately, these conditions are not always logically disjoint and easy to apply. The size and complexity of a program matters. Sometimes the tradeoffs change as an application evolves. Experience is required. When in doubt, prefer exceptions because their use scales better, and don't require external tools to check that all errors are handled.

Don't believe that all error codes or all exceptions are bad; there are clear uses for both. Furthermore, do not believe the myth that exception handling is slow; it is often faster than correct handling of complex or rare error conditions, and of repeated tests of error codes.

RAII (§4.2.2, §5.3) is essential for simple and efficient error-handling using exceptions. Code littered with `try`-blocks often simply reflects the worst aspects of error-handling strategies conceived for error codes.

3.5.4 Contracts

There is currently no general and standard way of writing optional run-time tests of invariants, pre-conditions, etc. A contract mechanism is proposed for C++20 [Garcia,2016] [Garcia,2018]. The aim is to support users who want to rely on testing to get programs right – running with extensive run-time checks – but then deploy code with minimal checks. This is popular in high-performance applications in organizations that rely on systematic and extensive checking.

For now, we have to rely on ad hoc mechanisms. For example, we could use a command-line macro to control a run-time check:

```
double& Vector::operator[](int i)
{
    if (RANGE_CHECK && (i<0 || size()<=i))
        throw out_of_range{"Vector::operator[]"};
    return elem[i];
}
```

The standard library offers the debug macro, `assert()`, to assert that a condition must hold at run time. For example:

```
void f(const char* p)
{
    assert(p!=nullptr); // p must not be the nullptr
    // ...
}
```

If the condition of an `assert()` fails in “debug mode,” the program terminates. If we are not in debug mode, the `assert()` is not checked. That's pretty crude and inflexible, but often sufficient.

3.5.5 Static Assertions

Exceptions report errors found at run time. If an error can be found at compile time, it is usually preferable to do so. That's what much of the type system and the facilities for specifying the interfaces to user-defined types are for. However, we can also perform simple checks on most

properties that are known at compile time and report failures to meet our expectations as compiler error messages. For example:

```
static_assert(4<=sizeof(int), "integers are too small"); // check integer size
```

This will write **integers are too small** if **4<=sizeof(int)** does not hold; that is, if an **int** on this system does not have at least 4 bytes. We call such statements of expectations *assertions*.

The **static_assert** mechanism can be used for anything that can be expressed in terms of constant expressions (§1.6). For example:

```
constexpr double C = 299792.458; // km/s

void f(double speed)
{
    constexpr double local_max = 160.0/(60*60); // 160 km/h == 160.0/(60*60) km/s

    static_assert(speed<C,"can't go that fast"); // error: speed must be a constant
    static_assert(local_max<C,"can't go that fast"); // OK

    // ...
}
```

In general, **static_assert(A,S)** prints **S** as a compiler error message if **A** is not **true**. If you don't want a specific message printed, leave out the **S** and the compiler will supply a default message:

```
static_assert(4<=sizeof(int)); // use default message
```

The default message is typically the source location of the **static_assert** plus a character representation of the asserted predicate.

The most important uses of **static_assert** come when we make assertions about types used as parameters in generic programming (§7.2, §13.9).

3.6 Function Arguments and Return Values

The primary and recommended way of passing information from one part of a program to another is through a function call. Information needed to perform a task is passed as arguments to a function and the results produced are passed back as return values. For example:

```
int sum(const vector<int>& v)
{
    int s = 0;
    for (const int i : v)
        s += i;
    return s;
}

vector fib = {1,2,3,5,8,13,21};

int x = sum(fib); // x becomes 53
```

There are other paths through which information can be passed between functions, such as global variables (§1.5), pointer and reference parameters (§3.6.1), and shared state in a class object (Chapter 4). Global variables are strongly discouraged as a known source of errors, and state should typically be shared only between functions jointly implementing a well-defined abstraction (e.g., member functions of a class; §2.3).

Given the importance of passing information to and from functions, it is not surprising that there are a variety of ways of doing it. Key concerns are:

- Is an object copied or shared?
- If an object is shared, is it mutable?
- Is an object moved, leaving an “empty object” behind (§5.2.2)?

The default behavior for both argument passing and value return is “copy” (§1.9), but some copies can implicitly be optimized to moves.

In the `sum()` example, the resulting `int` is copied out of `sum()` but it would be inefficient and pointless to copy the potentially very large `vector` into `sum()`, so the argument is passed by reference (indicated by the `&`; §1.7).

The `sum()` has no reason to modify its argument. This immutability is indicated by declaring the `vector` argument `const` (§1.6), so the `vector` is passed by `const`-reference.

3.6.1 Argument Passing

First consider how to get values into a function. By default we copy (“pass-by-value”) and if we want to refer to an object in the caller’s environment, we use a reference (“pass-by-reference”). For example:

```
void test(vector<int> v, vector<int>& rv)    // v is passed by value; rv is passed by reference
{
    v[1] = 99;        // modify v (a local variable)
    rv[2] = 66;      // modify whatever rv refers to
}

int main()
{
    vector fib = {1,2,3,5,8,13,21};
    test(fib, fib);
    cout << fib[1] << ' ' << fib[2] << '\n';    // prints 2 66
}
```

When we care about performance, we usually pass small values by-value and larger ones by-reference. Here “small” means “something that’s really cheap to copy.” Exactly what “small” means depends on machine architecture, but “the size of two or three pointers or less” is a good rule of thumb.

If we want to pass by reference for performance reasons but don’t need to modify the argument, we pass-by-`const`-reference as in the `sum()` example. This is by far the most common case in ordinary good code: it is fast and not error-prone.

It is not uncommon for a function argument to have a default value; that is, a value that is considered preferred or just the most common. We can specify such a default by a *default function argument*. For example:

```

void print(int value, int base =10); // print value in base "base"

print(x,16); // hexadecimal
print(x,60); // sexagesimal (Sumerian)
print(x); // use the default: decimal

```

This is a notationally simpler alternative to overloading:

```

void print(int value, int base); // print value in base "base"

void print(int value) // print value in base 10
{
    print(value,10);
}

```

3.6.2 Value Return

Once we have computed a result, we need to get it out of the function and back to the caller. Again, the default for value return is to copy and for small objects that's ideal. We return "by reference" only when we want to grant a caller access to something that is not local to the function. For example:

```

class Vector {
public:
    // ...
    double& operator[](int i) { return elem[i]; } // return reference to ith element
private:
    double* elem; // elem points to an array of sz
    // ...
};

```

The *i*th element of a **Vector** exists independently of the call of the subscript operator, so we can return a reference to it.

On the other hand, a local variable disappears when the function returns, so we should not return a pointer or reference to it:

```

int& bad()
{
    int x;
    // ...
    return x; // bad: return a reference to the local variable x
}

```

Fortunately, all major C++ compilers will catch the obvious error in **bad()**.

Returning a reference or a value of a "small" type is efficient, but how do we pass large amounts of information out of a function? Consider:

```

Matrix operator+(const Matrix& x, const Matrix& y)
{
    Matrix res;
    // ... for all res[i,j], res[i,j] = x[i,j]+y[i,j] ...
    return res;
}

Matrix m1, m2;
// ...
Matrix m3 = m1+m2;    // no copy

```

A **Matrix** may be *very* large and expensive to copy even on modern hardware. So we don't copy, we give **Matrix** a move constructor (§5.2.2) and very cheaply move the **Matrix** out of **operator+**. We do *not* need to regress to using manual memory management:

```

Matrix* add(const Matrix& x, const Matrix& y)    // complicated and error-prone 20th century style
{
    Matrix* p = new Matrix;
    // ... for all *p[i,j], *p[i,j] = x[i,j]+y[i,j] ...
    return p;
}

Matrix m1, m2;
// ...
Matrix* m3 = add(m1,m2);    // just copy a pointer
// ...
delete m3;                // easily forgotten

```

Unfortunately, returning large objects by returning a pointer to it is common in older code and a major source of hard-to-find errors. Don't write such code. Note that **operator+** is as efficient as **add()**, but far easier to define, easier to use, and less error-prone.

If a function cannot perform its required task, it can throw an exception (§3.5.1). This can help avoid code from being littered with error-code tests for "exceptional problems."

The return type of a function can be deduced from its return value. For example:

```

auto mul(int i, double d) { return i*d; }    // here, "auto" means "deduce the return type"

```

This can be convenient, especially for generic functions (function templates; §6.3.1) and lambdas (§6.3.3), but should be used carefully because a deduced type does not offer a stable interface: a change to the implementation of the function (or lambda) can change the type.

3.6.3 Structured Binding

A function can return only a single value, but that value can be a class object with many members. This allows us to efficiently return many values. For example:

```

struct Entry {
    string name;
    int value;
};

```

```

Entry read_entry(istream& is)    // naive read function (for a better version, see §10.5)
{
    string s;
    int i;
    is >> s >> i;
    return {s,i};
}

auto e = read_entry(cin);

cout << "{ " << e.name << " , " << e.value << " }\n";

```

Here, `{s,i}` is used to construct the `Entry` return value. Similarly, we can “unpack” an `Entry`’s members into local variables:

```

auto [n,v] = read_entry(is);
cout << "{ " << n << " , " << v << " }\n";

```

The `auto [n,v]` declares two local variables `n` and `v` with their types deduced from `read_entry()`’s return type. This mechanism for giving local names to members of a class object is called *structured binding*.

Consider another example:

```

map<string,int> m;
// ... fill m ...
for (const auto [key,value] : m)
    cout << "{ " << key << " , " << value << " }\n";

```

As usual, we can decorate `auto` with `const` and `&`. For example:

```

void incr(map<string,int>& m)    // increment the value of each element of m
{
    for (auto& [key,value] : m)
        ++value;
}

```

When structured binding is used for a class with no private data, it is easy to see how the binding is done: there must be the same number of names defined for the binding as there are nonstatic data members of the class, and each name introduced in the binding names the corresponding member. There will not be any difference in the object code quality compared to explicitly using a composite object; the use of structured binding is all about how best to express an idea.

It is also possible to handle classes where access is through member functions. For example:

```

complex<double> z = {1,2};
auto [re,im] = z+2;    // re=3; im=2

```

A `complex` has two data members, but its interface consists of access functions, such as `real()` and `imag()`. Mapping a `complex<double>` to two local variables, such as `re` and `im` is feasible and efficient, but the technique for doing so is beyond the scope of this book.

3.7 Advice

- [1] Distinguish between declarations (used as interfaces) and definitions (used as implementations); §3.1.
- [2] Use header files to represent interfaces and to emphasize logical structure; §3.2; [CG: SF.3].
- [3] **#include** a header in the source file that implements its functions; §3.2; [CG: SF.5].
- [4] Avoid non-inline function definitions in headers; §3.2; [CG: SF.2].
- [5] Prefer **modules** over headers (where **modules** are supported); §3.3.
- [6] Use namespaces to express logical structure; §3.4; [CG: SF.20].
- [7] Use **using**-directives for transition, for foundational libraries (such as **std**), or within a local scope; §3.4; [CG: SF.6] [CG: SF.7].
- [8] Don't put a **using**-directive in a header file; §3.4; [CG: SF.7].
- [9] Throw an exception to indicate that you cannot perform an assigned task; §3.5; [CG: E.2].
- [10] Use exceptions for error handling only; §3.5.3; [CG: E.3].
- [11] Use error codes when an immediate caller is expected to handle the error; §3.5.3.
- [12] Throw an exception if the error is expected to percolate up through many function calls; §3.5.3.
- [13] If in doubt whether to use an exception or an error code, prefer exceptions; §3.5.3.
- [14] Develop an error-handling strategy early in a design; §3.5; [CG: E.12].
- [15] Use purpose-designed user-defined types as exceptions (not built-in types); §3.5.1.
- [16] Don't try to catch every exception in every function; §3.5; [CG: E.7].
- [17] Prefer RAII to explicit **try**-blocks; §3.5.1, §3.5.2; [CG: E.6].
- [18] If your function may not throw, declare it **noexcept**; §3.5; [CG: E.12].
- [19] Let a constructor establish an invariant, and throw if it cannot; §3.5.2; [CG: E.5].
- [20] Design your error-handling strategy around invariants; §3.5.2; [CG: E.4].
- [21] What can be checked at compile time is usually best checked at compile time; §3.5.5 [CG: P.4] [CG: P.5].
- [22] Pass “small” values by value and “large” values by references; §3.6.1; [CG: F.16].
- [23] Prefer pass-by-**const**-reference over plain pass-by-reference; §3.6.1; [CG: F.17].
- [24] Return values as function-return values (rather than by out-parameters); §3.6.2; [CG: F.20] [CG: F.21].
- [25] Don't overuse return-type deduction; §3.6.2.
- [26] Don't overuse structured binding; using a named return type is often clearer documentation; §3.6.3.

4

Classes

*Those types are not “abstract”;
they are as real as **int** and **float**.*
– Doug McIlroy

- Introduction
- Concrete Types
 - An Arithmetic Type; A Container; Initializing Containers
- Abstract Types
- Virtual Functions
- Class Hierarchies
 - Benefits from Hierarchies; Hierarchy Navigation; Avoiding Resource Leaks
- Advice

4.1 Introduction

This chapter and the next three aim to give you an idea of C++’s support for abstraction and resource management without going into a lot of detail:

- This chapter informally presents ways of defining and using new types (*user-defined types*). In particular, it presents the basic properties, implementation techniques, and language facilities used for *concrete classes*, *abstract classes*, and *class hierarchies*.
- Chapter 5 presents the operations that have defined meaning in C++, such as constructors, destructors, and assignments. It outlines the rules for using those in combination to control the life cycle of objects and to support simple, efficient, and complete resource management.
- Chapter 6 introduces templates as a mechanism for parameterizing types and algorithms with (other) types and algorithms. Computations on user-defined and built-in types are represented as functions, sometimes generalized to *template functions* and *function objects*.
- Chapter 7 gives an overview of the concepts, techniques, and language features that underlie generic programming. The focus is on the definition and use of *concepts* for precisely

specifying interfaces to templates and guide design. *Variadic templates* are introduced for specifying the most general and most flexible interfaces.

These are the language facilities supporting the programming styles known as *object-oriented programming* and *generic programming*. Chapters 8–15 follow up by presenting examples of standard-library facilities and their use.

The central language feature of C++ is the *class*. A class is a user-defined type provided to represent a concept in the code of a program. Whenever our design for a program has a useful concept, idea, entity, etc., we try to represent it as a class in the program so that the idea is there in the code, rather than just in our heads, in a design document, or in some comments. A program built out of a well-chosen set of classes is far easier to understand and get right than one that builds everything directly in terms of the built-in types. In particular, classes are often what libraries offer.

Essentially all language facilities beyond the fundamental types, operators, and statements exist to help define better classes or to use them more conveniently. By “better,” I mean more correct, easier to maintain, more efficient, more elegant, easier to use, easier to read, and easier to reason about. Most programming techniques rely on the design and implementation of specific kinds of classes. The needs and tastes of programmers vary immensely. Consequently, the support for classes is extensive. Here, we will just consider the basic support for three important kinds of classes:

- Concrete classes (§4.2)
- Abstract classes (§4.3)
- Classes in class hierarchies (§4.5)

An astounding number of useful classes turn out to be of one of these three kinds. Even more classes can be seen as simple variants of these kinds or are implemented using combinations of the techniques used for these.

4.2 Concrete Types

The basic idea of *concrete classes* is that they behave “just like built-in types.” For example, a complex number type and an infinite-precision integer are much like built-in `int`, except of course that they have their own semantics and sets of operations. Similarly, a `vector` and a `string` are much like built-in arrays, except that they are better behaved (§9.2, §10.3, §11.2).

The defining characteristic of a concrete type is that its representation is part of its definition. In many important cases, such as a `vector`, that representation is only one or more pointers to data stored elsewhere, but that representation is present in each object of a concrete class. That allows implementations to be optimally efficient in time and space. In particular, it allows us to

- place objects of concrete types on the stack, in statically allocated memory, and in other objects (§1.5);
- refer to objects directly (and not just through pointers or references);
- initialize objects immediately and completely (e.g., using constructors; §2.3); and
- copy and move objects (§5.2).

The representation can be private (as it is for `Vector`; §2.3) and accessible only through the member functions, but it is present. Therefore, if the representation changes in any significant way, a user must recompile. This is the price to pay for having concrete types behave exactly like built-in

types. For types that don't change often, and where local variables provide much-needed clarity and efficiency, this is acceptable and often ideal. To increase flexibility, a concrete type can keep major parts of its representation on the free store (dynamic memory, heap) and access them through the part stored in the class object itself. That's the way **vector** and **string** are implemented; they can be considered resource handles with carefully crafted interfaces.

4.2.1 An Arithmetic Type

The “classical user-defined arithmetic type” is **complex**:

```
class complex {
    double re, im; // representation: two doubles
public:
    complex(double r, double i) :re{r}, im{i} {} // construct complex from two scalars
    complex(double r) :re{r}, im{0} {} // construct complex from one scalar
    complex() :re{0}, im{0} {} // default complex: {0,0}

    double real() const { return re; }
    void real(double d) { re=d; }
    double imag() const { return im; }
    void imag(double d) { im=d; }

    complex& operator+=(complex z)
    {
        re+=z.re; // add to re and im
        im+=z.im;
        return *this; // and return the result
    }

    complex& operator-=(complex z)
    {
        re-=z.re;
        im-=z.im;
        return *this;
    }

    complex& operator*=(complex); // defined out-of-class somewhere
    complex& operator/=(complex); // defined out-of-class somewhere
};
```

This is a slightly simplified version of the standard-library **complex** (§14.4). The class definition itself contains only the operations requiring access to the representation. The representation is simple and conventional. For practical reasons, it has to be compatible with what Fortran provided 60 years ago, and we need a conventional set of operators. In addition to the logical demands, **complex** must be efficient or it will remain unused. This implies that simple operations must be inlined. That is, simple operations (such as constructors, **+=**, and **imag()**) must be implemented without function calls in the generated machine code. Functions defined in a class are inlined by default. It is possible to explicitly request inlining by preceding a function declaration with the keyword **inline**.

An industrial-strength `complex` (like the standard-library one) is carefully implemented to do appropriate inlining.

A constructor that can be invoked without an argument is called a *default constructor*. Thus, `complex()` is `complex`'s default constructor. By defining a default constructor you eliminate the possibility of uninitialized variables of that type.

The `const` specifiers on the functions returning the real and imaginary parts indicate that these functions do not modify the object for which they are called. A `const` member function can be invoked for both `const` and non-`const` objects, but a non-`const` member function can only be invoked for non-`const` objects. For example:

```
complex z = {1,0};
const complex cz {1,3};
z = cz;           // OK: assigning to a non-const variable
cz = z;          // error: complex::operator=() is a non-const member function
double x = z.real(); // OK: complex::real() is a const member function
```

Many useful operations do not require direct access to the representation of `complex`, so they can be defined separately from the class definition:

```
complex operator+(complex a, complex b) { return a+=b; }
complex operator-(complex a, complex b) { return a-=b; }
complex operator-(complex a) { return {-a.real(), -a.imag()}; } // unary minus
complex operator*(complex a, complex b) { return a*=b; }
complex operator/(complex a, complex b) { return a/=b; }
```

Here, I use the fact that an argument passed by value is copied so that I can modify an argument without affecting the caller's copy and use the result as the return value.

The definitions of `==` and `!=` are straightforward:

```
bool operator==(complex a, complex b) // equal
{
    return a.real()==b.real() && a.imag()==b.imag();
}

bool operator!=(complex a, complex b) // not equal
{
    return !(a==b);
}

complex sqrt(complex); // the definition is elsewhere

// ...
```

Class `complex` can be used like this:

```
void f(complex z)
{
    complex a {2.3}; // construct {2.3,0.0} from 2.3
    complex b {1/a};
    complex c {a+z*complex{1,2.3}};
```

```

// ...
if (c != b)
    c = -(b/a)+2*b;
}

```

The compiler converts operators involving **complex** numbers into appropriate function calls. For example, $c!=b$ means `operator!=(c,b)` and $1/a$ means `operator/(complex{1},a)`.

User-defined operators (“overloaded operators”) should be used cautiously and conventionally. The syntax is fixed by the language, so you can’t define a unary `/`. Also, it is not possible to change the meaning of an operator for built-in types, so you can’t redefine `+` to subtract `ints`.

4.2.2 A Container

A *container* is an object holding a collection of elements. We call class **Vector** a container because objects of type **Vector** are containers. As defined in §2.3, **Vector** isn’t an unreasonable container of **doubles**: it is simple to understand, establishes a useful invariant (§3.5.2), provides range-checked access (§3.5.1), and provides `size()` to allow us to iterate over its elements. However, it does have a fatal flaw: it allocates elements using `new` but never deallocates them. That’s not a good idea because although C++ defines an interface for a garbage collector (§5.3), it is not guaranteed that one is available to make unused memory available for new objects. In some environments you can’t use a collector, and often you prefer more precise control of destruction for logical or performance reasons. We need a mechanism to ensure that the memory allocated by the constructor is deallocated; that mechanism is a *destructor*:

```

class Vector {
public:
    Vector(int s) : elem{new double[s]}, sz{s}    // constructor: acquire resources
    {
        for (int i=0; i!=s; ++i)                // initialize elements
            elem[i]=0;
    }

    ~Vector() { delete[] elem; }                // destructor: release resources

    double& operator[](int i);
    int size() const;
private:
    double* elem;    // elem points to an array of sz doubles
    int sz;
};

```

The name of a destructor is the complement operator, `~`, followed by the name of the class; it is the complement of a constructor. **Vector**’s constructor allocates some memory on the free store (also called the *heap* or *dynamic store*) using the `new` operator. The destructor cleans up by freeing that memory using the `delete[]` operator. Plain `delete` deletes an individual object, `delete[]` deletes an array.

This is all done without intervention by users of **Vector**. The users simply create and use **Vectors** much as they would variables of built-in types. For example:

```

void fct(int n)
{
    Vector v(n);
    // ... use v ...
    {
        Vector v2(2*n);
        // ... use v and v2 ...
    } // v2 is destroyed here
    // ... use v ..
} // v is destroyed here

```

Vector obeys the same rules for naming, scope, allocation, lifetime, etc. (§1.5), as does a built-in type, such as **int** and **char**. This **Vector** has been simplified by leaving out error handling; see §3.5.

The constructor/destructor combination is the basis of many elegant techniques. In particular, it is the basis for most C++ general resource management techniques (§5.3, §13.2). Consider a graphical illustration of a **Vector**:

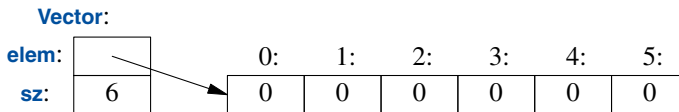

The constructor allocates the elements and initializes the **Vector** members appropriately. The destructor deallocates the elements. This *handle-to-data model* is very commonly used to manage data that can vary in size during the lifetime of an object. The technique of acquiring resources in a constructor and releasing them in a destructor, known as *Resource Acquisition Is Initialization* or *RAII*, allows us to eliminate “naked **new** operations,” that is, to avoid allocations in general code and keep them buried inside the implementation of well-behaved abstractions. Similarly, “naked **delete** operations” should be avoided. Avoiding naked **new** and naked **delete** makes code far less error-prone and far easier to keep free of resource leaks (§13.2).

4.2.3 Initializing Containers

A container exists to hold elements, so obviously we need convenient ways of getting elements into a container. We can create a **Vector** with an appropriate number of elements and then assign to them, but typically other ways are more elegant. Here, I just mention two favorites:

- *Initializer-list constructor*: Initialize with a list of elements.
- **push_back()**: Add a new element at the end of (at the back of) the sequence.

These can be declared like this:

```

class Vector {
public:
    Vector(std::initializer_list<double>); // initialize with a list of doubles
    // ...
    void push_back(double); // add element at end, increasing the size by one
    // ...
};

```

The `push_back()` is useful for input of arbitrary numbers of elements. For example:

```

Vector read(istream& is)
{
    Vector v;
    for (double d; is>>d; )           // read floating-point values into d
        v.push_back(d);             // add d to v
    return v;
}

```

The input loop is terminated by an end-of-file or a formatting error. Until that happens, each number read is added to the `Vector` so that at the end, `v`'s size is the number of elements read. I used a `for`-statement rather than the more conventional `while`-statement to keep the scope of `d` limited to the loop. The way to provide `Vector` with a move constructor, so that returning a potentially huge amount of data from `read()` is cheap, is explained in §5.2.2:

```

Vector v = read(cin);    // no copy of Vector elements here

```

The way that `std::vector` is represented to make `push_back()` and other operations that change a `vector`'s size efficient is presented in §11.2.

The `std::initializer_list` used to define the initializer-list constructor is a standard-library type known to the compiler: when we use a `{}`-list, such as `{1,2,3,4}`, the compiler will create an object of type `initializer_list` to give to the program. So, we can write:

```

Vector v1 = {1,2,3,4,5};           // v1 has 5 elements
Vector v2 = {1.23, 3.45, 6.7, 8};  // v2 has 4 elements

```

`Vector`'s initializer-list constructor might be defined like this:

```

Vector::Vector(std::initializer_list<double> lst) // initialize with a list
    :elem{new double[lst.size()]}, sz{static_cast<int>(lst.size())}
{
    copy(lst.begin(),lst.end(),elem);           // copy from lst into elem (§12.6)
}

```

Unfortunately, the standard-library uses `unsigned` integers for sizes and subscripts, so I need to use the ugly `static_cast` to explicitly convert the size of the initializer list to an `int`. This is pedantic because the chance that the number of elements in a handwritten list is larger than the largest integer (32,767 for 16-bit integers and 2,147,483,647 for 32-bit integers) is rather low. However, the type system has no common sense. It knows about the possible values of variables, rather than actual values, so it might complain where there is no actual violation. Such warnings can occasionally save the programmer from a bad error.

A `static_cast` does not check the value it is converting; the programmer is trusted to use it correctly. This is not always a good assumption, so if in doubt, check the value. Explicit type conversions (often called *casts* to remind you that they are used to prop up something broken) are best avoided. Try to use unchecked casts only for the lowest level of a system. They are error-prone.

Other casts are `reinterpret_cast` for treating an object as simply a sequence of bytes and `const_cast` for “casting away `const`.” Judicious use of the type system and well-designed libraries allow us to eliminate unchecked casts in higher-level software.

4.3 Abstract Types

Types such as **complex** and **Vector** are called *concrete types* because their representation is part of their definition. In that, they resemble built-in types. In contrast, an *abstract type* is a type that completely insulates a user from implementation details. To do that, we decouple the interface from the representation and give up genuine local variables. Since we don't know anything about the representation of an abstract type (not even its size), we must allocate objects on the free store (§4.2.2) and access them through references or pointers (§1.7, §13.2.1).

First, we define the interface of a class **Container**, which we will design as a more abstract version of our **Vector**:

```
class Container {
public:
    virtual double& operator[](int) = 0;           // pure virtual function
    virtual int size() const = 0;                // const member function (§4.2.1)
    virtual ~Container() {}                     // destructor (§4.2.2)
};
```

This class is a pure interface to specific containers defined later. The word **virtual** means “may be redefined later in a class derived from this one.” Unsurprisingly, a function declared **virtual** is called a *virtual function*. A class derived from **Container** provides an implementation for the **Container** interface. The curious **=0** syntax says the function is *pure virtual*; that is, some class derived from **Container** *must* define the function. Thus, it is not possible to define an object that is just a **Container**. For example:

```
Container c; // error: there can be no objects of an abstract class
Container* p = new Vector_container(10); // OK: Container is an interface
```

A **Container** can only serve as the interface to a class that implements its **operator[]()** and **size()** functions. A class with a pure virtual function is called an *abstract class*.

This **Container** can be used like this:

```
void use(Container& c)
{
    const int sz = c.size();

    for (int i=0; i!=sz; ++i)
        cout << c[i] << '\n';
}
```

Note how **use()** uses the **Container** interface in complete ignorance of implementation details. It uses **size()** and **[]** without any idea of exactly which type provides their implementation. A class that provides the interface to a variety of other classes is often called a *polymorphic type*.

As is common for abstract classes, **Container** does not have a constructor. After all, it does not have any data to initialize. On the other hand, **Container** does have a destructor and that destructor is **virtual**, so that classes derived from **Container** can provide implementations. Again, that is common for abstract classes because they tend to be manipulated through references or pointers, and someone destroying a **Container** through a pointer has no idea what resources are owned by its implementation; see also §4.5.

The abstract class `Container` defines only an interface and no implementation. For `Container` to be useful, we have to implement a container that implements the functions required by its interface. For that, we could use the concrete class `Vector`:

```
class Vector_container : public Container { // Vector_container implements Container
public:
    Vector_container(int s) : v(s) { // Vector of s elements
        ~Vector_container() {}

        double& operator[](int i) override { return v[i]; }
        int size() const override { return v.size(); }
private:
    Vector v;
};
```

The `:public` can be read as “is derived from” or “is a subtype of.” Class `Vector_container` is said to be *derived* from class `Container`, and class `Container` is said to be a *base* of class `Vector_container`. An alternative terminology calls `Vector_container` and `Container` *subclass* and *superclass*, respectively. The derived class is said to inherit members from its base class, so the use of base and derived classes is commonly referred to as *inheritance*.

The members `operator[]()` and `size()` are said to *override* the corresponding members in the base class `Container`. I used the explicit `override` to make clear what’s intended. The use of `override` is optional, but being explicit allows the compiler to catch mistakes, such as misspellings of function names or slight differences between the type of a `virtual` function and its intended overrider. The explicit use of `override` is particularly useful in larger class hierarchies where it can otherwise be hard to know what is supposed to override what.

The destructor (`~Vector_container()`) overrides the base class destructor (`~Container()`). Note that the member destructor (`~Vector()`) is implicitly invoked by its class’s destructor (`~Vector_container()`).

For a function like `use(Container&)` to use a `Container` in complete ignorance of implementation details, some other function will have to make an object on which it can operate. For example:

```
void g()
{
    Vector_container vc(10); // Vector of ten elements
    // ... fill vc ...
    use(vc);
}
```

Since `use()` doesn’t know about `Vector_containers` but only knows the `Container` interface, it will work just as well for a different implementation of a `Container`. For example:

```
class List_container : public Container { // List_container implements Container
public:
    List_container() { // empty List
    List_container(initializer_list<double> il) : l{il} {}
    ~List_container() {}
```

```

    double& operator[](int i) override;
    int size() const override { return ld.size(); }
private:
    std::list<double> ld;    // (standard-library) list of doubles (§11.3)
};

double& List_container::operator[](int i)
{
    for (auto& x : ld) {
        if (i==0)
            return x;
        --i;
    }
    throw out_of_range{"List container"};
}

```

Here, the representation is a standard-library `list<double>`. Usually, I would not implement a container with a subscript operation using a `list`, because performance of `list` subscripting is atrocious compared to `vector` subscripting. However, here I just wanted to show an implementation that is radically different from the usual one.

A function can create a `List_container` and have `use()` use it:

```

void h()
{
    List_container lc = { 1, 2, 3, 4, 5, 6, 7, 8, 9 };
    use(lc);
}

```

The point is that `use(Container&)` has no idea if its argument is a `Vector_container`, a `List_container`, or some other kind of container; it doesn't need to know. It can use any kind of `Container`. It knows only the interface defined by `Container`. Consequently, `use(Container&)` needn't be recompiled if the implementation of `List_container` changes or a brand-new class derived from `Container` is used.

The flip side of this flexibility is that objects must be manipulated through pointers or references (§5.2, §13.2.1).

4.4 Virtual Functions

Consider again the use of `Container`:

```

void use(Container& c)
{
    const int sz = c.size();

    for (int i=0; i!=sz; ++i)
        cout << c[i] << '\n';
}

```

How is the call `c[i]` in `use()` resolved to the right `operator[]()`? When `h()` calls `use()`, `List_container`'s `operator[]()` must be called. When `g()` calls `use()`, `Vector_container`'s `operator[]()` must be called. To

achieve this resolution, a **Container** object must contain information to allow it to select the right function to call at run time. The usual implementation technique is for the compiler to convert the name of a virtual function into an index into a table of pointers to functions. That table is usually called the *virtual function table* or simply the **vtbl**. Each class with virtual functions has its own **vtbl** identifying its virtual functions. This can be represented graphically like this:

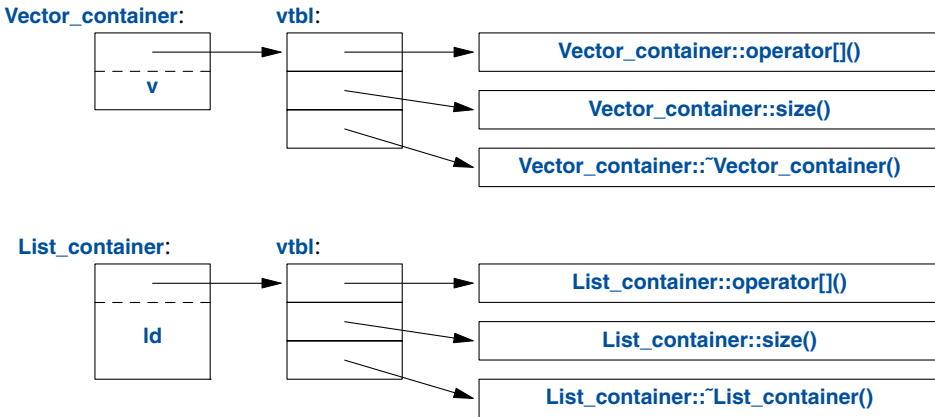

The functions in the **vtbl** allow the object to be used correctly even when the size of the object and the layout of its data are unknown to the caller. The implementation of the caller needs only to know the location of the pointer to the **vtbl** in a **Container** and the index used for each virtual function. This virtual call mechanism can be made almost as efficient as the “normal function call” mechanism (within 25%). Its space overhead is one pointer in each object of a class with virtual functions plus one **vtbl** for each such class.

4.5 Class Hierarchies

The **Container** example is a very simple example of a class hierarchy. A *class hierarchy* is a set of classes ordered in a lattice created by derivation (e.g., **public**). We use class hierarchies to represent concepts that have hierarchical relationships, such as “A fire engine is a kind of a truck which is a kind of a vehicle” and “A smiley face is a kind of a circle which is a kind of a shape.” Huge hierarchies, with hundreds of classes, that are both deep and wide are common. As a semi-realistic classic example, let’s consider shapes on a screen:

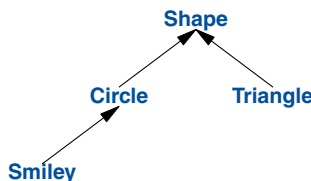

The arrows represent inheritance relationships. For example, class **Circle** is derived from class

Shape. A class hierarchy is conventionally drawn growing down from the most basic class, the root, towards the (later defined) derived classes. To represent that simple diagram in code, we must first specify a class that defines the general properties of all shapes:

```
class Shape {
public:
    virtual Point center() const =0;    // pure virtual
    virtual void move(Point to) =0;

    virtual void draw() const = 0;    // draw on current "Canvas"
    virtual void rotate(int angle) = 0;

    virtual ~Shape() {}                // destructor
    // ...
};
```

Naturally, this interface is an abstract class: as far as representation is concerned, *nothing* (except the location of the pointer to the `vtbl`) is common for every **Shape**. Given this definition, we can write general functions manipulating vectors of pointers to shapes:

```
void rotate_all(vector<Shape*>& v, int angle) // rotate v's elements by angle degrees
{
    for (auto p : v)
        p->rotate(angle);
}
```

To define a particular shape, we must say that it is a **Shape** and specify its particular properties (including its virtual functions):

```
class Circle : public Shape {
public:
    Circle(Point p, int rad);        // constructor

    Point center() const override
    {
        return x;
    }
    void move(Point to) override
    {
        x = to;
    }

    void draw() const override;
    void rotate(int) override {}    // nice simple algorithm
private:
    Point x; // center
    int r;   // radius
};
```

So far, the **Shape** and **Circle** example provides nothing new compared to the **Container** and **Vector_container** example, but we can build further:

```

class Smiley : public Circle { // use the circle as the base for a face
public:
    Smiley(Point p, int rad) : Circle{p,rad}, mouth{nullptr} {}

    ~Smiley()
    {
        delete mouth;
        for (auto p : eyes)
            delete p;
    }

    void move(Point to) override;

    void draw() const override;
    void rotate(int) override;

    void add_eye(Shape* s)
    {
        eyes.push_back(s);
    }
    void set_mouth(Shape* s);
    virtual void wink(int i); // wink eye number i

    // ...

private:
    vector<Shape*> eyes; // usually two eyes
    Shape* mouth;
};

```

The `push_back()` member of `vector` copies its argument into the `vector` (here, `eyes`) as the last element, increasing that vector's size by one.

We can now define `Smiley::draw()` using calls to `Smiley`'s base and member `draw()`s:

```

void Smiley::draw() const
{
    Circle::draw();
    for (auto p : eyes)
        p->draw();
    mouth->draw();
}

```

Note the way that `Smiley` keeps its eyes in a standard-library `vector` and deletes them in its destructor. `Shape`'s destructor is `virtual` and `Smiley`'s destructor overrides it. A virtual destructor is essential for an abstract class because an object of a derived class is usually manipulated through the interface provided by its abstract base class. In particular, it may be deleted through a pointer to a base class. Then, the virtual function call mechanism ensures that the proper destructor is called. That destructor then implicitly invokes the destructors of its bases and members.

In this simplified example, it is the programmer's task to place the eyes and mouth appropriately within the circle representing the face.

We can add data members, operations, or both as we define a new class by derivation. This gives great flexibility with corresponding opportunities for confusion and poor design.

4.5.1 Benefits from Hierarchies

A class hierarchy offers two kinds of benefits:

- *Interface inheritance*: An object of a derived class can be used wherever an object of a base class is required. That is, the base class acts as an interface for the derived class. The **Container** and **Shape** classes are examples. Such classes are often abstract classes.
- *Implementation inheritance*: A base class provides functions or data that simplifies the implementation of derived classes. **Smiley**'s uses of **Circle**'s constructor and of **Circle::draw()** are examples. Such base classes often have data members and constructors.

Concrete classes – especially classes with small representations – are much like built-in types: we define them as local variables, access them using their names, copy them around, etc. Classes in class hierarchies are different: we tend to allocate them on the free store using **new**, and we access them through pointers or references. For example, consider a function that reads data describing shapes from an input stream and constructs the appropriate **Shape** objects:

```
enum class Kind { circle, triangle, smiley };

Shape* read_shape(istream& is) // read shape descriptions from input stream is
{
    // ... read shape header from is and find its Kind k ...

    switch (k) {
    case Kind::circle:
        // read circle data {Point,int} into p and r
        return new Circle{p,r};
    case Kind::triangle:
        // read triangle data {Point,Point,Point} into p1, p2, and p3
        return new Triangle{p1,p2,p3};
    case Kind::smiley:
        // read smiley data {Point,int,Shape,Shape,Shape} into p, r, e1, e2, and m
        Smiley* ps = new Smiley{p,r};
        ps->add_eye(e1);
        ps->add_eye(e2);
        ps->set_mouth(m);
        return ps;
    }
}
```

A program may use that shape reader like this:

```

void user()
{
    std::vector<Shape*> v;
    while (cin)
        v.push_back(read_shape(cin));
    draw_all(v);           // call draw() for each element
    rotate_all(v,45);     // call rotate(45) for each element
    for (auto p : v)      // remember to delete elements
        delete p;
}

```

Obviously, the example is simplified – especially with respect to error handling – but it vividly illustrates that `user()` has absolutely no idea of which kinds of shapes it manipulates. The `user()` code can be compiled once and later used for new `Shapes` added to the program. Note that there are no pointers to the shapes outside `user()`, so `user()` is responsible for deallocating them. This is done with the `delete` operator and relies critically on `Shape`'s virtual destructor. Because that destructor is virtual, `delete` invokes the destructor for the most derived class. This is crucial because a derived class may have acquired all kinds of resources (such as file handles, locks, and output streams) that need to be released. In this case, a `Smiley` deletes its `eyes` and `mouth` objects. Once it has done that, it calls `Circle`'s destructor. Objects are constructed “bottom up” (base first) by constructors and destroyed “top down” (derived first) by destructors.

4.5.2 Hierarchy Navigation

The `read_shape()` function returns `Shape*` so that we can treat all `Shapes` alike. However, what can we do if we want to use a member function that is only provided by a particular derived class, such as `Smiley`'s `wink()`? We can ask “is this `Shape` a kind of `Smiley`?” using the `dynamic_cast` operator:

```

Shape* ps {read_shape(cin)};

if (Smiley* p = dynamic_cast<Smiley*>(ps)) { // ... does ps point to a Smiley? ...
    // ... a Smiley; use it
}
else {
    // ... not a Smiley, try something else ...
}

```

If at run time the object pointed to by the argument of `dynamic_cast` (here, `ps`) is not of the expected type (here, `Smiley`) or a class derived from the expected type, `dynamic_cast` returns `nullptr`.

We use `dynamic_cast` to a pointer type when a pointer to an object of a different derived class is a valid argument. We then test whether the result is `nullptr`. This test can often conveniently be placed in the initialization of a variable in a condition.

When a different type is unacceptable, we can simply `dynamic_cast` to a reference type. If the object is not of the expected type, `dynamic_cast` throws a `bad_cast` exception:

```

Shape* ps {read_shape(cin)};
Smiley& r {dynamic_cast<Smiley&>(*ps)}; // somewhere, catch std::bad_cast

```

Code is cleaner when `dynamic_cast` is used with restraint. If we can avoid using type information,

we can write simpler and more efficient code, but occasionally type information is lost and must be recovered. This typically happens when we pass an object to some system that accepts an interface specified by a base class. When that system later passes the object back to us, we might have to recover the original type. Operations similar to `dynamic_cast` are known as “is kind of” and “is instance of” operations.

4.5.3 Avoiding Resource Leaks

Experienced programmers will have noticed that I left open three opportunities for mistakes:

- The implementer of `Smiley` may fail to `delete` the pointer to `mouth`.
- A user of `read_shape()` might fail to `delete` the pointer returned.
- The owner of a container of `Shape` pointers might fail to `delete` the objects pointed to.

In that sense, pointers to objects allocated on the free store is dangerous: a “plain old pointer” should not be used to represent ownership. For example:

```
void user(int x)
{
    Shape* p = new Circle(Point{0,0},10);
    // ...
    if (x<0) throw Bad_x{}; // potential leak
    if (x==0) return;      // potential leak
    // ...
    delete p;
}
```

This will leak unless `x` is positive. Assigning the result of `new` to a “naked pointer” is asking for trouble.

One simple solution to such problems is to use a standard-library `unique_ptr` (§13.2.1) rather than a “naked pointer” when deletion is required:

```
class Smiley : public Circle {
    // ...
private:
    vector<unique_ptr<Shape>> eyes; // usually two eyes
    unique_ptr<Shape> mouth;
};
```

This is an example of a simple, general, and efficient technique for resource management (§5.3).

As a pleasant side effect of this change, we no longer need to define a destructor for `Smiley`. The compiler will implicitly generate one that does the required destruction of the `unique_ptr`s (§5.3) in the `vector`. The code using `unique_ptr` will be exactly as efficient as code using the raw pointers correctly.

Now consider users of `read_shape()`:

```
unique_ptr<Shape> read_shape(istream& is) // read shape descriptions from input stream is
{
    // read shape header from is and find its Kind k
```

```

switch (k) {
case Kind::circle:
    // read circle data {Point,int} into p and r
    return unique_ptr<Shape>{new Circle{p,r}};    // §13.2.1
// ...
}

void user()
{
    vector<unique_ptr<Shape>> v;
    while (cin)
        v.push_back(read_shape(cin));
    draw_all(v);                // call draw() for each element
    rotate_all(v,45);           // call rotate(45) for each element
} // all Shapes implicitly destroyed

```

Now each object is owned by a `unique_ptr` that will `delete` the object when it is no longer needed, that is, when its `unique_ptr` goes out of scope.

For the `unique_ptr` version of `user()` to work, we need versions of `draw_all()` and `rotate_all()` that accept `vector<unique_ptr<Shape>>s`. Writing many such `_all()` functions could become tedious, so §6.3.2 shows an alternative.

4.6 Advice

- [1] Express ideas directly in code; §4.1; [CG: P.1].
- [2] A concrete type is the simplest kind of class. Where applicable, prefer a concrete type over more complicated classes and over plain data structures; §4.2; [CG: C.10].
- [3] Use concrete classes to represent simple concepts; §4.2.
- [4] Prefer concrete classes over class hierarchies for performance-critical components; §4.2.
- [5] Define constructors to handle initialization of objects; §4.2.1, §5.1.1; [CG: C.40] [CG: C.41].
- [6] Make a function a member only if it needs direct access to the representation of a class; §4.2.1; [CG: C.4].
- [7] Define operators primarily to mimic conventional usage; §4.2.1; [CG: C.160].
- [8] Use nonmember functions for symmetric operators; §4.2.1; [CG: C.161].
- [9] Declare a member function that does not modify the state of its object `const`; §4.2.1.
- [10] If a constructor acquires a resource, its class needs a destructor to release the resource; §4.2.2; [CG: C.20].
- [11] Avoid “naked” `new` and `delete` operations; §4.2.2; [CG: R.11].
- [12] Use resource handles and RAII to manage resources; §4.2.2; [CG: R.1].
- [13] If a class is a container, give it an initializer-list constructor; §4.2.3; [CG: C.103].
- [14] Use abstract classes as interfaces when complete separation of interface and implementation is needed; §4.3; [CG: C.122].
- [15] Access polymorphic objects through pointers and references; §4.3.
- [16] An abstract class typically doesn’t need a constructor; §4.3; [CG: C.126].
- [17] Use class hierarchies to represent concepts with inherent hierarchical structure; §4.5.

- [18] A class with a virtual function should have a virtual destructor; §4.5; [CG: C.127].
- [19] Use **override** to make overriding explicit in large class hierarchies; §4.5.1; [CG: C.128].
- [20] When designing a class hierarchy, distinguish between implementation inheritance and interface inheritance; §4.5.1; [CG: C.129].
- [21] Use **dynamic_cast** where class hierarchy navigation is unavoidable; §4.5.2; [CG: C.146].
- [22] Use **dynamic_cast** to a reference type when failure to find the required class is considered a failure; §4.5.2; [CG: C.147].
- [23] Use **dynamic_cast** to a pointer type when failure to find the required class is considered a valid alternative; §4.5.2; [CG: C.148].
- [24] Use **unique_ptr** or **shared_ptr** to avoid forgetting to **delete** objects created using **new**; §4.5.3; [CG: C.149].

Essential Operations

*When someone says
I want a programming language in which
I need only say what I wish done,
give him a lollipop.
– Alan Perlis*

- Introduction
 - Essential Operations; Conversions; Member Initializers
- Copy and Move
 - Copying Containers; Moving Containers
- Resource Management
- Conventional Operations
 - Comparisons; Container Operations; Input and Output Operators; User-Defined Literals;
`swap()`; `hash<>`
- Advice

5.1 Introduction

Some operations, such as initialization, assignment, copy, and move, are fundamental in the sense that language rules make assumptions about them. Other operations, such as `==` and `<<`, have conventional meanings that are perilous to ignore.

5.1.1 Essential Operations

Construction of objects plays a key role in many designs. This wide variety of uses is reflected in the range and flexibility of the language features supporting initialization.

Constructors, destructors, and copy and move operations for a type are not logically separate. We must define them as a matched set or suffer logical or performance problems. If a class `X` has a

destructor that performs a nontrivial task, such as free-store deallocation or lock release, the class is likely to need the full complement of functions:

```
class X {
public:
    X(Sometype);           // "ordinary constructor": create an object
    X();                  // default constructor
    X(const X&);          // copy constructor
    X(X&&);               // move constructor
    X& operator=(const X&); // copy assignment: clean up target and copy
    X& operator=(X&&);    // move assignment: clean up target and move
    ~X();                 // destructor: clean up
    // ...
};
```

There are five situations in which an object can be copied or moved:

- As the source of an assignment
- As an object initializer
- As a function argument
- As a function return value
- As an exception

An assignment uses a copy or move assignment operator. In principle, the other cases use a copy or move constructor. However, a copy or move constructor invocation is often optimized away by constructing the object used to initialize right in the target object. For example:

```
X make(Sometype);
X x = make(value);
```

Here, a compiler will typically construct the **X** from **make()** directly in **x**; thus eliminating (“eliding”) a copy.

In addition to the initialization of named objects and of objects on the free store, constructors are used to initialize temporary objects and to implement explicit type conversion.

Except for the “ordinary constructor,” these special member functions will be generated by the compiler as needed. If you want to be explicit about generating default implementations, you can:

```
class Y {
public:
    Y(Sometype);
    Y(const Y&) = default; // I really do want the default copy constructor
    Y(Y&&) = default;     // and the default move constructor
    // ...
};
```

If you are explicit about some defaults, other default definitions will not be generated.

When a class has a pointer member, it is usually a good idea to be explicit about copy and move operations. The reason is that a pointer may point to something that the class needs to **delete**, in which case the default memberwise copy would be wrong. Alternatively, it might point to something that the class must *not* **delete**. In either case, a reader of the code would like to know. For an example, see §5.2.1.

A good rule of thumb (sometimes called *the rule of zero*) is to either define all of the essential operations or none (using the default for all). For example:

```
struct Z {
    Vector v;
    string s;
};

Z z1;           // default initialize z1.v and z1.s
Z z2 = z1;     // default copy z1.v and z1.s
```

Here, the compiler will synthesize memberwise default construction, copy, move, and destructor as needed, and all with the correct semantics.

To complement `=default`, we have `=delete` to indicate that an operation is not to be generated. A base class in a class hierarchy is the classical example where we don't want to allow a memberwise copy. For example:

```
class Shape {
public:
    Shape(const Shape&) =delete;           // no copy operations
    Shape& operator=(const Shape&) =delete;
    // ...
};

void copy(Shape& s1, const Shape& s2)
{
    s1 = s2; // error: Shape copy is deleted
}
```

A `=delete` makes an attempted use of the `deleted` function a compile-time error; `=delete` can be used to suppress any function, not just essential member functions.

5.1.2 Conversions

A constructor taking a single argument defines a conversion from its argument type. For example, `complex` (§4.2.1) provides a constructor from a `double`:

```
complex z1 = 3.14; // z1 becomes {3.14,0.0}
complex z2 = z1*2; // z2 becomes z1*{2.0,0} == {6.28,0.0}
```

This implicit conversion is sometimes ideal, but not always. For example, `Vector` (§4.2.2) provides a constructor from an `int`:

```
Vector v1 = 7; // OK: v1 has 7 elements
```

This is typically considered unfortunate, and the standard-library `vector` does not allow this `int-to-vector` “conversion.”

The way to avoid this problem is to say that only explicit “conversion” is allowed; that is, we can define the constructor like this:

```
class Vector {
public:
    explicit Vector(int s);    // no implicit conversion from int to Vector
    // ...
};
```

That gives us:

```
Vector v1(7);    // OK: v1 has 7 elements
Vector v2 = 7;  // error: no implicit conversion from int to Vector
```

When it comes to conversions, more types are like **Vector** than are like **complex**, so use **explicit** for constructors that take a single argument unless there is a good reason not to.

5.1.3 Member Initializers

When a data member of a class is defined, we can supply a default initializer called a *default member initializer*. Consider a revision of **complex** (§4.2.1):

```
class complex {
    double re = 0;
    double im = 0; // representation: two doubles with default value 0.0
public:
    complex(double r, double i) :re{r}, im{i} {}    // construct complex from two scalars: {r,i}
    complex(double r) :re{r} {}                    // construct complex from one scalar: {r,0}
    complex() {}                                    // default complex: {0,0}
    // ...
};
```

The default value is used whenever a constructor doesn't provide a value. This simplifies code and helps us to avoid accidentally leaving a member uninitialized.

5.2 Copy and Move

By default, objects can be copied. This is true for objects of user-defined types as well as for built-in types. The default meaning of copy is memberwise copy: copy each member. For example, using **complex** from §4.2.1:

```
void test(complex z1)
{
    complex z2 {z1};    // copy initialization
    complex z3;
    z3 = z2;           // copy assignment
    // ...
}
```

Now **z1**, **z2**, and **z3** have the same value because both the assignment and the initialization copied both members.

When we design a class, we must always consider if and how an object might be copied. For simple concrete types, memberwise copy is often exactly the right semantics for copy. For some

sophisticated concrete types, such as **Vector**, memberwise copy is not the right semantics for copy; for abstract types it almost never is.

5.2.1 Copying Containers

When a class is a *resource handle* – that is, when the class is responsible for an object accessed through a pointer – the default memberwise copy is typically a disaster. Memberwise copy would violate the resource handle’s invariant (§3.5.2). For example, the default copy would leave a copy of a **Vector** referring to the same elements as the original:

```
void bad_copy(Vector v1)
{
    Vector v2 = v1;    // copy v1's representation into v2
    v1[0] = 2;        // v2[0] is now also 2!
    v2[1] = 3;        // v1[1] is now also 3!
}
```

Assuming that **v1** has four elements, the result can be represented graphically like this:

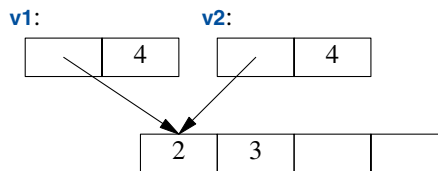

Fortunately, the fact that **Vector** has a destructor is a strong hint that the default (memberwise) copy semantics is wrong and the compiler should at least warn against this example. We need to define better copy semantics.

Copying of an object of a class is defined by two members: a *copy constructor* and a *copy assignment*:

```
class Vector {
private:
    double* elem; // elem points to an array of sz doubles
    int sz;
public:
    Vector(int s); // constructor: establish invariant, acquire resources
    ~Vector() { delete[] elem; } // destructor: release resources

    Vector(const Vector& a); // copy constructor
    Vector& operator=(const Vector& a); // copy assignment

    double& operator[](int i);
    const double& operator[](int i) const;

    int size() const;
};
```

A suitable definition of a copy constructor for **Vector** allocates the space for the required number of

elements and then copies the elements into it so that after a copy each **Vector** has its own copy of the elements:

```
Vector::Vector(const Vector& a) // copy constructor
:elem{new double[a.sz]},      // allocate space for elements
sz{a.sz}
{
    for (int i=0; i!=sz; ++i) // copy elements
        elem[i] = a.elem[i];
}
```

The result of the `v2=v1` example can now be presented as:

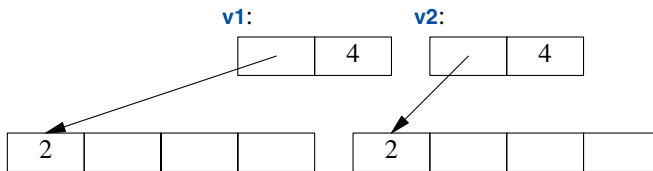

Of course, we need a copy assignment in addition to the copy constructor:

```
Vector& Vector::operator=(const Vector& a) // copy assignment
{
    double* p = new double[a.sz];
    for (int i=0; i!=a.sz; ++i)
        p[i] = a.elem[i];
    delete[] elem; // delete old elements
    elem = p;
    sz = a.sz;
    return *this;
}
```

The name `this` is predefined in a member function and points to the object for which the member function is called.

5.2.2 Moving Containers

We can control copying by defining a copy constructor and a copy assignment, but copying can be costly for large containers. We avoid the cost of copying when we pass objects to a function by using references, but we can't return a reference to a local object as the result (the local object would be destroyed by the time the caller got a chance to look at it). Consider:

```
Vector operator+(const Vector& a, const Vector& b)
{
    if (a.size()!=b.size())
        throw Vector_size_mismatch{};

    Vector res(a.size());
```

```

    for (int i=0; i!=a.size(); ++i)
        res[i]=a[i]+b[i];
    return res;
}

```

Returning from a `+` involves copying the result out of the local variable `res` and into some place where the caller can access it. We might use this `+` like this:

```

void f(const Vector& x, const Vector& y, const Vector& z)
{
    Vector r;
    // ...
    r = x+y+z;
    // ...
}

```

That would be copying a `Vector` at least twice (one for each use of the `+` operator). If a `Vector` is large, say, 10,000 `doubles`, that could be embarrassing. The most embarrassing part is that `res` in `operator+()` is never used again after the copy. We didn't really want a copy; we just wanted to get the result out of a function: we wanted to *move* a `Vector` rather than *copy* it. Fortunately, we can state that intent:

```

class Vector {
    // ...

    Vector(const Vector& a);           // copy constructor
    Vector& operator=(const Vector& a); // copy assignment

    Vector(Vector&& a);                // move constructor
    Vector& operator=(Vector&& a);     // move assignment
};

```

Given that definition, the compiler will choose the *move constructor* to implement the transfer of the return value out of the function. This means that `r=x+y+z` will involve no copying of `Vectors`. Instead, `Vectors` are just moved.

As is typical, `Vector`'s move constructor is trivial to define:

```

Vector::Vector(Vector&& a)
    :elem{a.elem},           // "grab the elements" from a
    sz{a.sz}
{
    a.elem = nullptr;       // now a has no elements
    a.sz = 0;
}

```

The `&&` means “rvalue reference” and is a reference to which we can bind an rvalue. The word “rvalue” is intended to complement “lvalue,” which roughly means “something that can appear on the left-hand side of an assignment.” So an rvalue is – to a first approximation – a value that you can't assign to, such as an integer returned by a function call. Thus, an rvalue reference is a reference to something that *nobody else* can assign to, so we can safely “steal” its value. The `res` local variable in `operator+()` for `Vectors` is an example.

A move constructor does *not* take a **const** argument: after all, a move constructor is supposed to remove the value from its argument. A *move assignment* is defined similarly.

A move operation is applied when an rvalue reference is used as an initializer or as the right-hand side of an assignment.

After a move, a moved-from object should be in a state that allows a destructor to be run. Typically, we also allow assignment to a moved-from object. The standard-library algorithms (Chapter 12) assumes that. Our **Vector** does that.

Where the programmer knows that a value will not be used again, but the compiler can't be expected to be smart enough to figure that out, the programmer can be specific:

```

Vector f()
{
    Vector x(1000);
    Vector y(2000);
    Vector z(3000);
    z = x;           // we get a copy (x might be used later in f())
    y = std::move(x); // we get a move (move assignment)
    // ... better not use x here ...
    return z;       // we get a move
}

```

The standard-library function **move()** doesn't actually move anything. Instead, it returns a reference to its argument from which we may move – an *rvalue reference*; it is a kind of cast (§4.2.3).

Just before the **return** we have:

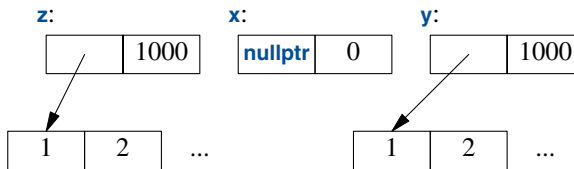

When we return from **f()**, **z** is destroyed after its elements has been moved out of **f()** by the **return**. However, **y**'s destructor will **delete[]** its elements.

The compiler is obliged (by the C++ standard) to eliminate most copies associated with initialization, so move constructors are not invoked as often as you might imagine. This *copy elision* eliminates even the very minor overhead of a move. On the other hand, it is typically not possible to implicitly eliminate copy or move operations from assignments, so move assignments can be critical for performance.

5.3 Resource Management

By defining constructors, copy operations, move operations, and a destructor, a programmer can provide complete control of the lifetime of a contained resource (such as the elements of a container). Furthermore, a move constructor allows an object to move simply and cheaply from one scope to another. That way, objects that we cannot or would not want to copy out of a scope can be

simply and cheaply moved out instead. Consider a standard-library `thread` representing a concurrent activity (§15.2) and a `Vector` of a million `doubles`. We can't copy the former and don't want to copy the latter.

```
std::vector<thread> my_threads;

Vector init(int n)
{
    thread t {heartbeat};           // run heartbeat concurrently (in a separate thread)
    my_threads.push_back(std::move(t)); // move t into my_threads (§13.2.2)
    // ... more initialization ...

    Vector vec(n);
    for (int i=0; i!=vec.size(); ++i)
        vec[i] = 777;
    return vec;                     // move vec out of init()
}

auto v = init(1'000'000);           // start heartbeat and initialize v
```

Resource handles, such as `Vector` and `thread`, are superior alternatives to direct use of built-in pointers in many cases. In fact, the standard-library “smart pointers,” such as `unique_ptr`, are themselves resource handles (§13.2.1).

I used the standard-library `vector` to hold the `threads` because we don't get to parameterize our simple `Vector` with an element type until §6.2.

In very much the same way that `new` and `delete` disappear from application code, we can make pointers disappear into resource handles. In both cases, the result is simpler and more maintainable code, without added overhead. In particular, we can achieve *strong resource safety*; that is, we can eliminate resource leaks for a general notion of a resource. Examples are `vectors` holding memory, `threads` holding system threads, and `fstreams` holding file handles.

In many languages, resource management is primarily delegated to a garbage collector. C++ also offers a garbage collection interface so that you can plug in a garbage collector. However, I consider garbage collection the last choice after cleaner, more general, and better localized alternatives to resource management have been exhausted. My ideal is not to create any garbage, thus eliminating the need for a garbage collector: Do not litter!

Garbage collection is fundamentally a global memory management scheme. Clever implementations can compensate, but as systems are getting more distributed (think caches, multicores, and clusters), locality is more important than ever.

Also, memory is not the only resource. A resource is anything that has to be acquired and (explicitly or implicitly) released after use. Examples are memory, locks, sockets, file handles, and thread handles. Unsurprisingly, a resource that is not just memory is called a *non-memory resource*. A good resource management system handles all kinds of resources. Leaks must be avoided in any long-running system, but excessive resource retention can be almost as bad as a leak. For example, if a system holds on to memory, locks, files, etc. for twice as long, the system needs to be provisioned with potentially twice as many resources.

Before resorting to garbage collection, systematically use resource handles: let each resource have an owner in some scope and by default be released at the end of its owners scope. In C++,

this is known as *RAII* (*Resource Acquisition Is Initialization*) and is integrated with error handling in the form of exceptions. Resources can be moved from scope to scope using move semantics or “smart pointers,” and shared ownership can be represented by “shared pointers” (§13.2.1).

In the C++ standard library, RAII is pervasive: for example, memory (**string**, **vector**, **map**, **unordered_map**, etc.), files (**ifstream**, **ofstream**, etc.), threads (**thread**), locks (**lock_guard**, **unique_lock**, etc.), and general objects (through **unique_ptr** and **shared_ptr**). The result is implicit resource management that is invisible in common use and leads to low resource retention durations.

5.4 Conventional Operations

Some operations have conventional meanings when defined for a type. These conventional meanings are often assumed by programmers and libraries (notably, the standard library), so it is wise to conform to them when designing new types for which the operations make sense.

- Comparisons: **==**, **!=**, **<**, **<=**, **>**, and **>=** (§5.4.1)
- Container operations: **size()**, **begin()**, and **end()** (§5.4.2)
- Input and output operations: **>>** and **<<** (§5.4.3)
- User-defined literals (§5.4.4)
- **swap()** (§5.4.5)
- Hash functions: **hash<>** (§5.4.6)

5.4.1 Comparisons

The meaning of the equality comparisons (**==** and **!=**) is closely related to copying. After a copy, the copies should compare equal:

```
X a = something;
X b = a;
assert(a==b); // if a!=b here, something is very odd (§3.5.4).
```

When defining **==**, also define **!=** and make sure that **a!=b** means **!(a==b)**.

Similarly, if you define **<**, also define **<=**, **>**, **>=**, and make sure that the usual equivalences hold:

- **a<=b** means **(a<b)||!(a==b)** and **!(b<a)**.
- **a>b** means **b<a**.
- **a>=b** means **(a>b)||!(a==b)** and **!(a<b)**.

To give identical treatment to both operands of a binary operator, such as **==**, it is best defined as a free-standing function in the namespace of its class. For example:

```
namespace NX {
    class X {
        // ...
    };
    bool operator==(const X&, const X&);
    // ...
};
```

5.4.2 Container Operations

Unless there is a really good reason not to, design containers in the style of the standard-library containers (Chapter 11). In particular, make the container resource safe by implementing it as a handle with appropriate essential operations (§5.1.1, §5.2).

The standard-library containers all know their number of elements and we can obtain it by calling `size()`. For example:

```
for (size_t i = 0; i < c.size(); ++i)    // size_t is the name of the type returned by a standard-library size()
    c[i] = 0;
```

However, rather than traversing containers using indices from `0` to `size()`, the standard algorithms (Chapter 12) rely on the notion of *sequences* delimited by pairs of *iterators*:

```
for (auto p = c.begin(); p != c.end(); ++p)
    *p = 0;
```

Here, `c.begin()` is an iterator pointing to the first element of `c` and `c.end()` points one-beyond-the-last element of `c`. Like pointers, iterators support `++` to move to the next element and `*` to access the value of the element pointed to. This *iterator model* (§12.3) allows for great generality and efficiency. Iterators are used to pass sequences to standard-library algorithms. For example:

```
sort(v.begin(), v.end());
```

For details and more container operations, see Chapter 11 and Chapter 12.

Another way of using the number of elements implicitly is a range-`for` loop:

```
for (auto& x : c)
    x = 0;
```

This uses `c.begin()` and `c.end()` implicitly and is roughly equivalent to the more explicit loop.

5.4.3 Input and Output Operations

For pairs of integers, `<<` means left-shift and `>>` means right-shift. However, for `iostreams`, they are the output and input operator, respectively (§1.8, Chapter 10). For details and more I/O operations, see Chapter 10.

5.4.4 User-Defined Literals

One purpose of classes was to enable the programmer to design and implement types to closely mimic built-in types. Constructors provide initialization that equals or exceeds the flexibility and efficiency of built-in type initialization, but for built-in types, we have literals:

- `123` is an `int`.
- `0xFF00u` is an `unsigned int`.
- `123.456` is a `double`.
- `"Surprise!"` is a `const char[10]`.

It can be useful to provide such literals for a user-defined type also. This is done by defining the meaning of a suitable suffix to a literal, so we can get

- `"Surprise!"s` is a `std::string`.
- `123s` is `seconds`.
- `12.7i` is `imaginary` so that `12.7i+47` is a `complex number` (i.e., `{47,12.7}`).

In particular, we can get these examples from the standard library by using suitable headers and namespaces:

Standard-Library Suffixes for Literals		
<code><chrono></code>	<code>std::literals::chrono_literals</code>	<code>h, min, s, ms, us, ns</code>
<code><string></code>	<code>std::literals::string_literals</code>	<code>s</code>
<code><string_view></code>	<code>std::literals::string_literals</code>	<code>sv</code>
<code><complex></code>	<code>std::literals::complex_literals</code>	<code>i, il, if</code>

Unsurprisingly, literals with user-defined suffixes are called *user-defined literals* or *UDLs*. Such literals are defined using *literal operators*. A literal operator converts a literal of its argument type, followed by a subscript, into its return type. For example, the `i` for `imaginary` suffix might be implemented like this:

```
constexpr complex<double> operator""i(long double arg) // imaginary literal
{
    return {0,arg};
}
```

Here

- The `operator""` indicates that we are defining a literal operator.
- The `i` after the “literal indicator” `""` is the suffix to which the operator gives a meaning.
- The argument type, `long double`, indicates that the suffix (`i`) is being defined for a floating-point literal.
- The return type, `complex<double>`, specifies the type of the resulting literal.

Given that, we can write

```
complex<double> z = 2.7182818+6.283185i;
```

5.4.5 `swap()`

Many algorithms, most notably `sort()`, use a `swap()` function that exchanges the values of two objects. Such algorithms generally assume that `swap()` is very fast and doesn't throw an exception. The standard-library provides a `std::swap(a,b)` implemented as three move operations: `(tmp=a, a=b, b=tmp)`. If you design a type that is expensive to copy and could plausibly be swapped (e.g., by a sort function), then give it move operations or a `swap()` or both. Note that the standard-library containers (Chapter 11) and `string` (§9.2.1) have fast move operations.

5.4.6 `hash<>`

The standard-library `unordered_map<K,V>` is a hash table with `K` as the key type and `V` as the value type (§11.5). To use a type `X` as a key, we must define `hash<X>`. The standard library does that for us for common types, such as `std::string`.

5.5 Advice

- [1] Control construction, copy, move, and destruction of objects; §5.1.1; [CG: R.1].
- [2] Design constructors, assignments, and the destructor as a matched set of operations; §5.1.1; [CG: C.22].
- [3] Define all essential operations or none; §5.1.1; [CG: C.21].
- [4] If a default constructor, assignment, or destructor is appropriate, let the compiler generate it (don't rewrite it yourself); §5.1.1; [CG: C.20].
- [5] If a class has a pointer member, consider if it needs a user-defined or deleted destructor, copy and move; §5.1.1; [CG: C.32] [CG: C.33].
- [6] If a class has a user-defined destructor, it probably needs user-defined or deleted copy and move; §5.2.1.
- [7] By default, declare single-argument constructors **explicit**; §5.1.1; [CG: C.46].
- [8] If a class member has a reasonable default value, provide it as a data member initializer; §5.1.3; [CG: C.48].
- [9] Redefine or prohibit copying if the default is not appropriate for a type; §5.2.1, §4.6.5; [CG: C.61].
- [10] Return containers by value (relying on move for efficiency); §5.2.2; [CG: F.20].
- [11] For large operands, use **const** reference argument types; §5.2.2; [CG: F.16].
- [12] Provide strong resource safety; that is, never leak anything that you think of as a resource; §5.3; [CG: R.1].
- [13] If a class is a resource handle, it needs a user-defined constructor, a destructor, and non-default copy operations; §5.3; [CG: R.1].
- [14] Overload operations to mimic conventional usage; §5.4; [CG: C.160].
- [15] Follow the standard-library container design; §5.4.2; [CG: C.100].

This page intentionally left blank

6

Templates

Your quote here.
– B. Stroustrup

- Introduction
- Parameterized Types
 - Constrained Template Arguments; Value Template Arguments; Template Argument Deduction
- Parameterized Operations
 - Function Templates; Function Objects; Lambda Expressions
- Template Mechanisms
 - Variable Templates; Aliases; Compile-Time `if`
- Advice

6.1 Introduction

Someone who wants a vector is unlikely always to want a vector of `doubles`. A vector is a general concept, independent of the notion of a floating-point number. Consequently, the element type of a vector ought to be represented independently. A *template* is a class or a function that we parameterize with a set of types or values. We use templates to represent ideas that are best understood as something general from which we can generate specific types and functions by specifying arguments, such as the `vector`'s element type `double`.

6.2 Parameterized Types

We can generalize our vector-of-doubles type to a vector-of-anything type by making it a `template` and replacing the specific type `double` with a type parameter. For example:

```

template<typename T>
class Vector {
private:
    T* elem; // elem points to an array of sz elements of type T
    int sz;
public:
    explicit Vector(int s);           // constructor: establish invariant, acquire resources
    ~Vector() { delete[] elem; }     // destructor: release resources

    // ... copy and move operations ...

    T& operator[](int i);           // for non-const Vectors
    const T& operator[](int i) const; // for const Vectors (§4.2.1)
    int size() const { return sz; }
};

```

The `template<typename T>` prefix makes `T` a parameter of the declaration it prefixes. It is C++’s version of the mathematical “for all `T`” or more precisely “for all types `T`.” If you want the mathematical “for all `T`, such that `P(T)`,” you need concepts (§6.2.1, §7.2). Using `class` to introduce a type parameter is equivalent to using `typename`, and in older code we often see `template<class T>` as the prefix.

The member functions might be defined similarly:

```

template<typename T>
Vector<T>::Vector(int s)
{
    if (s<0)
        throw Negative_size{};
    elem = new T[s];
    sz = s;
}

template<typename T>
const T& Vector<T>::operator[](int i) const
{
    if (i<0 || size()<=i)
        throw out_of_range{"Vector::operator[]"};
    return elem[i];
}

```

Given these definitions, we can define `Vectors` like this:

```

Vector<char> vc(200);           // vector of 200 characters
Vector<string> vs(17);         // vector of 17 strings
Vector<list<int>> vli(45);     // vector of 45 lists of integers

```

The `>>` in `Vector<list<int>>` terminates the nested template arguments; it is not a misplaced input operator.

We can use `Vectors` like this:

```

void write(const Vector<string>& vs)           // Vector of some strings
{
    for (int i = 0; i!=vs.size(); ++i)
        cout << vs[i] << '\n';
}

```

To support the range-`for` loop for our `Vector`, we must define suitable `begin()` and `end()` functions:

```

template<typename T>
T* begin(Vector<T>& x)
{
    return x.size() ? &x[0] : nullptr;      // pointer to first element or nullptr
}

template<typename T>
T* end(Vector<T>& x)
{
    return x.size() ? &x[0]+x.size() : nullptr;    // pointer to one-past-last element
}

```

Given those, we can write:

```

void f2(Vector<string>& vs)   // Vector of some strings
{
    for (auto& s : vs)
        cout << s << '\n';
}

```

Similarly, we can define lists, vectors, maps (that is, associative arrays), unordered maps (that is, hash tables), etc., as templates (Chapter 11).

Templates are a compile-time mechanism, so their use incurs no run-time overhead compared to hand-crafted code. In fact, the code generated for `Vector<double>` is identical to the code generated for the version of `Vector` from Chapter 4. Furthermore, the code generated for the standard-library `vector<double>` is likely to be better (because more effort has gone into its implementation).

A template plus a set of template arguments is called an *instantiation* or a *specialization*. Late in the compilation process, at *instantiation time*, code is generated for each instantiation used in a program (§7.5). The code generated is type checked so that the generated code is as type safe as handwritten code. Unfortunately, that type check often occurs late in the compilation process, at instantiation time.

6.2.1 Constrained Template Arguments (C++20)

Most often, a template will make sense only for template arguments that meet certain criteria. For example, a `Vector` typically offers a copy operation, and if it does, it must require that its elements must be copyable. That is, we must require that `Vector`'s template argument is not just a `typename` but an `Element` where “`Element`” specifies the requirements of a type that can be an element:

```

template<Element T>
class Vector {
private:
    T* elem; // elem points to an array of sz elements of type T
    int sz;
    // ...
};

```

This `template<Element T>` prefix is C++’s version of mathematic’s “for all T such that `Element(T)`”; that is, `Element` is a predicate that checks whether `T` has all the properties that a `Vector` requires. Such a predicate is called a *concept* (§7.2). A template argument for which a concept is specified is called a *constrained argument* and a template for which an argument is constrained is called a *constrained template*.

It is a compile-time error to try to instantiate a template with a type that does not meet its requirements. For example:

```

Vector<int> v1; // OK: we can copy an int
Vector<thread> v2; // error: we can't copy a standard thread (§15.2)

```

Since C++ does not officially support concepts before C++20, older code uses unconstrained template arguments and leaves requirements to documentation.

6.2.2 Value Template Arguments

In addition to type arguments, a template can take value arguments. For example:

```

template<typename T, int N>
struct Buffer {
    using value_type = T;
    constexpr int size() { return N; }
    T[N];
    // ...
};

```

The alias (`value_type`) and the `constexpr` function are provided to allow users (read-only) access to the template arguments.

Value arguments are useful in many contexts. For example, `Buffer` allows us to create arbitrarily sized buffers with no use of the free store (dynamic memory):

```

Buffer<char,1024> glob; // global buffer of characters (statically allocated)

void fct()
{
    Buffer<int,10> buf; // local buffer of integers (on the stack)
    // ...
}

```

A template value argument must be a constant expression.

6.2.3 Template Argument Deduction

Consider using the standard-library template `pair`:

```
pair<int,double> p = {1,5.2};
```

Many have found the need to specify the template argument types tedious, so the standard library offers a function, `make_pair()`, that deduces the template arguments of the `pair` it returns from its function arguments:

```
auto p = make_pair(1,5.2);    // p is a pair<int,double>
```

This leads to the obvious question “Why can’t we just deduce template parameters from constructor arguments?” So, in C++17, we can. That is:

```
pair p = {1,5.2};    // p is a pair<int,double>
```

This is not just a problem with `pair`; `make_` functions are very common. Consider a simple example:

```
template<typename T>  
class Vector {  
public:  
    Vector(int);  
    Vector(initializer_list<T>);    // initializer-list constructor  
    // ...  
};  
  
Vector v1 {1,2,3};    // deduce v1's element type from the initializer element type  
Vector v2 = v1;    // deduce v2's element type from v1's element type  
  
auto p = new Vector{1,2,3};    // p points to a Vector<int>  
  
Vector<int> v3(1);    // here we need to be explicit about the element type (no element type is mentioned)
```

Clearly, this simplifies notation and can eliminate annoyances caused by mistyping redundant template argument types. However, it is not a panacea. Deduction can cause surprises (both for `make_` functions and constructors). Consider:

```
Vector<string> vs1 {"Hello", "World"};    // Vector<string>  
Vector vs {"Hello", "World"};    // deduces to Vector<const char*> (Surprise?)  
Vector vs2 {"Hello"s, "World"s};    // deduces to Vector<string>  
Vector vs3 {"Hello"s, "World"};    // error: the initializer list is not homogenous
```

The type of a C-style string literal is `const char*` (§1.7.1). If that was not what was intended, use the `s` suffix to make it a proper `string` (§9.2). If elements of an initializer list have differing types, we cannot deduce a unique element type, so we get an error.

When a template argument cannot be deduced from the constructor arguments, we can help by providing a *deduction guide*. Consider:

```

template<typename T>
class Vector2 {
public:
    using value_type = T;
    // ...
    Vector2(initializer_list<T>); // initializer-list constructor

    template<typename Iter>
        Vector2(Iter b, Iter e); // [b:e) range constructor
    // ...
};

Vector2 v1 {1,2,3,4,5}; // element type is int
Vector2 v2(v1.begin(),v1.begin()+2);

```

Obviously, `v2` should be a `Vector2<int>`, but without help, the compiler cannot deduce that. The code only states that there is a constructor from a pair of values of the same type. Without language support for concepts (§7.2), the compiler cannot assume anything about that type. To allow deduction, we can add a *deduction guide* after the declaration of `Vector2`:

```

template<typename Iter>
    Vector2(Iter,Iter) -> Vector2<typename Iter::value_type>;

```

That is, if we see a `Vector2` initialized by a pair of iterators, we should deduce `Vector2::value_type` to be the iterator's value type.

The effects of deduction guides are often subtle, so it is best to design class templates so that deduction guides are not needed. However, the standard library is full of classes that don't (yet) use **concepts** (§7.2) and have such ambiguities, so it uses quite a few deduction guides.

6.3 Parameterized Operations

Templates have many more uses than simply parameterizing a container with an element type. In particular, they are extensively used for parameterization of both types and algorithms in the standard library (§11.6, §12.6).

There are three ways of expressing an operation parameterized by types or values:

- A function template
- A function object: an object that can carry data and be called like a function
- A lambda expression: a shorthand notation for a function object

6.3.1 Function Templates

We can write a function that calculates the sum of the element values of any sequence that a range-**for** can traverse (e.g., a container) like this:

```
template<typename Sequence, typename Value>
Value sum(const Sequence& s, Value v)
{
    for (auto x : s)
        v+=x;
    return v;
}
```

The **Value** template argument and the function argument **v** are there to allow the caller to specify the type and initial value of the accumulator (the variable in which to accumulate the sum):

```
void user(Vector<int>& vi, list<double>& ld, vector<complex<double>>& vc)
{
    int x = sum(vi,0);           // the sum of a vector of ints (add ints)
    double d = sum(vi,0.0);     // the sum of a vector of ints (add doubles)
    double dd = sum(ld,0.0);    // the sum of a list of doubles
    auto z = sum(vc,complex{0.0,0.0}); // the sum of a vector of complex<double>s
}
```

The point of adding **ints** in a **double** would be to gracefully handle a number larger than the largest **int**. Note how the types of the template arguments for **sum<Sequence,Value>** are deduced from the function arguments. Fortunately, we do not need to explicitly specify those types.

This **sum()** is a simplified version of the standard-library **accumulate()** (§14.3).

A function template can be a member function, but not a **virtual** member. The compiler would not know all instantiations of such a template in a program, so it could not generate a **vtbl** (§4.4).

6.3.2 Function Objects

One particularly useful kind of template is the *function object* (sometimes called a *functor*), which is used to define objects that can be called like functions. For example:

```
template<typename T>
class Less_than {
    const T val; // value to compare against
public:
    Less_than(const T& v) :val{v} { }
    bool operator()(const T& x) const { return x<val; } // call operator
};
```

The function called **operator()** implements the “function call,” “call,” or “application” operator (**()**).

We can define named variables of type **Less_than** for some argument type:

```
Less_than lti {42};           // lti(i) will compare i to 42 using < (i<42)
Less_than lts {"Backus"s};   // lts(s) will compare s to "Backus" using < (s<"Backus")
Less_than<string> lts2 {"Naur"}; // "Naur" is a C-style string, so we need <string> to get the right <
```

We can call such an object, just as we call a function:

```

void fct(int n, const string& s)
{
    bool b1 = lti(n);    // true if n<42
    bool b2 = lts(s);    // true if s<"Backus"
    // ...
}

```

Such function objects are widely used as arguments to algorithms. For example, we can count the occurrences of values for which a predicate returns **true**:

```

template<typename C, typename P>
    // requires Sequence<C> && Callable<P, Value_type<P>>
int count(const C& c, P pred)
{
    int cnt = 0;
    for (const auto& x : c)
        if (pred(x))
            ++cnt;
    return cnt;
}

```

A *predicate* is something that we can invoke to return **true** or **false**. For example:

```

void f(const Vector<int>& vec, const list<string>& lst, int x, const string& s)
{
    cout << "number of values less than " << x << ": " << count(vec, Less_than{x}) << '\n';
    cout << "number of values less than " << s << ": " << count(lst, Less_than{s}) << '\n';
}

```

Here, **Less_than{x}** constructs an object of type **Less_than<int>**, for which the call operator compares to the **int** called **x**; **Less_than{s}** constructs an object that compares to the **string** called **s**. The beauty of these function objects is that they carry the value to be compared against with them. We don't have to write a separate function for each value (and each type), and we don't have to introduce nasty global variables to hold values. Also, for a simple function object like **Less_than**, inlining is simple, so a call of **Less_than** is far more efficient than an indirect function call. The ability to carry data plus their efficiency makes function objects particularly useful as arguments to algorithms.

Function objects used to specify the meaning of key operations of a general algorithm (such as **Less_than** for **count()**) are often referred to as *policy objects*.

6.3.3 Lambda Expressions

In §6.3.2, we defined **Less_than** separately from its use. That can be inconvenient. Consequently, there is a notation for implicitly generating function objects:

```

void f(const Vector<int>& vec, const list<string>& lst, int x, const string& s)
{
    cout << "number of values less than " << x
         << ": " << count(vec, [&](int a){ return a<x; })
         << '\n';
}

```

```

    cout << "number of values less than " << s
         << ": " << count(lst,[&](const string& a){ return a<s; })
         << '\n';
}

```

The notation `[&](int a){ return a<x; }` is called a *lambda expression*. It generates a function object exactly like `Less_than<int>{x}`. The `[&]` is a *capture list* specifying that all local names used in the lambda body (such as `x`) will be accessed through references. Had we wanted to “capture” only `x`, we could have said so: `[x]`. Had we wanted to give the generated object a copy of `x`, we could have said so: `[=x]`. Capture nothing is `[]`, capture all local names used by reference is `[&]`, and capture all local names used by value is `[=]`.

Using lambdas can be convenient and terse, but also obscure. For nontrivial actions (say, more than a simple expression), I prefer to name the operation so as to more clearly state its purpose and to make it available for use in several places in a program.

In §4.5.3, we noted the annoyance of having to write many functions to perform operations on elements of **vectors** of pointers and **unique_ptrs**, such as `draw_all()` and `rotate_all()`. Function objects (in particular, lambdas) can help by allowing us to separate the traversal of the container from the specification of what is to be done with each element.

First, we need a function that applies an operation to each object pointed to by the elements of a container of pointers:

```

template<typename C, typename Oper>
void for_all(C& c, Oper op)           // assume that C is a container of pointers
    // requires Sequence<C> && Callable<Oper, Value_type<C>> (see §7.2.1)
{
    for (auto& x : c)
        op(x);                       // pass op() a reference to each element pointed to
}

```

Now, we can write a version of `user()` from §4.5 without writing a set of `_all` functions:

```

void user2()
{
    vector<unique_ptr<Shape>> v;
    while (cin)
        v.push_back(read_shape(cin));
    for_all(v,[](unique_ptr<Shape>& ps){ ps->draw(); });           // draw_all()
    for_all(v,[](unique_ptr<Shape>& ps){ ps->rotate(45); });       // rotate_all(45)
}

```

I pass a `unique_ptr<Shape>&` to a lambda so that `for_all()` doesn’t have to care exactly how the objects are stored. In particular, those `for_all()` calls do not affect the lifetime of the **Shapes** passed and the bodies of the lambdas use the argument just as if they had been a plain-old pointers.

Like a function, a lambda can be generic. For example:

```

template<class S>
void rotate_and_draw(vector<S>& v, int r)
{
    for_all(v,[](auto& s){ s->rotate(r); s->draw(); });
}

```

Here, like in variable declarations, **auto** means that any type is accepted as an initializer (an argument is considered to initialize the formal parameter in a call). This makes a lambda with an **auto** parameter a template, a *generic lambda*. For reasons lost in standards committee politics, this use of **auto** is not currently allowed for function arguments.

We can call this generic **rotate_and_draw()** with any container of objects that you can **draw()** and **rotate()**. For example:

```
void user4()
{
    vector<unique_ptr<Shape>> v1;
    vector<Shape*> v2;
    // ...
    rotate_and_draw(v1,45);
    rotate_and_draw(v2,90);
}
```

Using a lambda, we can turn any statement into an expression. This is mostly used to provide an operation to compute a value as an argument value, but the ability is general. Consider a complicated initialization:

```
enum class Init_mode { zero, seq, cpy, patrn };    // initializer alternatives

// messy code:

// int n, Init_mode m, vector<int>& arg, and iterators p and q are defined somewhere

vector<int> v;

switch (m) {
case zero:
    v = vector<int>(n); // n elements initialized to 0
    break;
case cpy:
    v = arg;
    break;
};

// ...

if (m == seq)
    v.assign(p,q);    // copy from sequence [p:q)

// ...
```

This is a stylized example, but unfortunately not atypical. We need to select among a set of alternatives for initializing a data structure (here **v**) and we need to do different computations for different alternatives. Such code is often messy, deemed essential “for efficiency,” and a source of bugs:

- The variable could be used before it gets its intended value.
- The “initialization code” could be mixed with other code, making it hard to comprehend.

- When “initialization code” is mixed with other code it is easier to forget a case.
- This isn’t initialization, it’s assignment.

Instead, we could convert it to a lambda used as an initializer:

```
// int n, Init_mode m, vector<int>& arg, and iterators p and q are defined somewhere

vector<int> v = [&] {
    switch (m) {
    case zero:
        return vector<int>(n);           // n elements initialized to 0
    case seq:
        return vector<int>{p,q};        // copy from sequence [p:q]
    case cpy:
        return arg;
    }
};
// ...
```

I still “forgot” a `case`, but now that’s easily spotted.

6.4 Template Mechanisms

To define good templates, we need some supporting language facilities:

- Values dependent on a type: *variable templates* (§6.4.1).
- Aliases for types and templates: *alias templates* (§6.4.2).
- A compile-time selection mechanism: `if constexpr` (§6.4.3).
- A compile-time mechanism to inquire about properties of types and expressions: `requires-expressions` (§7.2.3).

In addition, `constexpr` functions (§1.6) and `static_asserts` (§3.5.5) often take part in template design and use.

These basic mechanisms are primarily tools for building general, foundational abstractions.

6.4.1 Variable Templates

When we use a type, we often want constants and values of that type. This is of course also the case when we use a class template: when we define a `C<T>`, we often want constants and variables of type `T` and other types depending on `T`. Here is an example from a fluid dynamic simulation [Garcia,2015]:

```
template <class T>
    constexpr T viscosity = 0.4;

template <class T>
    constexpr space_vector<T> external_acceleration = { T(), T{-9.8}, T{} };

auto vis2 = 2*viscosity<double>;
auto acc = external_acceleration<float>;
```

Here, `space_vector` is a three-dimensional vector.

Naturally, we can use arbitrary expressions of suitable type as initializers. Consider:

```
template<typename T, typename T2>
    constexpr bool Assignable = is_assignable<T&,T2>::value; // is_assignable is a type trait (§13.9.1)

template<typename T>
void testing()
{
    static_assert(Assignable<T&,double>, "can't assign a double");
    static_assert(Assignable<T&,string>, "can't assign a string");
}

```

After some significant mutations, this idea becomes the heart of concept definitions (§7.2).

6.4.2 Aliases

Surprisingly often, it is useful to introduce a synonym for a type or a template. For example, the standard header `<cstdlib>` contains a definition of the alias `size_t`, maybe:

```
using size_t = unsigned int;
```

The actual type named `size_t` is implementation-dependent, so in another implementation `size_t` may be an `unsigned long`. Having the alias `size_t` allows the programmer to write portable code.

It is very common for a parameterized type to provide an alias for types related to their template arguments. For example:

```
template<typename T>
class Vector {
public:
    using value_type = T;
    // ...
};

```

In fact, every standard-library container provides `value_type` as the name of its value type (Chapter 11). This allows us to write code that will work for every container that follows this convention. For example:

```
template<typename C>
using Value_type = typename C::value_type; // the type of C's elements

template<typename Container>
void algo(Container& c)
{
    Vector<Value_type<Container>> vec; // keep results here
    // ...
}

```

The aliasing mechanism can be used to define a new template by binding some or all template arguments. For example:

```

template<typename Key, typename Value>
class Map {
    // ...
};

template<typename Value>
using String_map = Map<string, Value>;

String_map<int> m;    // m is a Map<string, int>

```

6.4.3 Compile-Time if

Consider writing an operation that can use one of two operations `slow_and_safe(T)` or `simple_and_fast(T)`. Such problems abound in foundational code where generality and optimal performance are essential. The traditional solution is to write a pair of overloaded functions and select the most appropriate based on a trait (§13.9.1), such as the standard-library `is_pod`. If a class hierarchy is involved, a base class can provide the `slow_and_safe` general operation and a derived class can override with a `simple_and_fast` implementation.

In C++17, we can use a compile-time `if`:

```

template<typename T>
void update(T& target)
{
    // ...
    if constexpr(is_pod<T>::value)
        simple_and_fast(target); // for "plain old data"
    else
        slow_and_safe(target);
    // ...
}

```

The `is_pod<T>` is a type trait (§13.9.1) that tells us whether a type can be trivially copied.

Only the selected branch of an `if constexpr` is instantiated. This solution offers optimal performance and locality of the optimization.

Importantly, an `if constexpr` is not a text-manipulation mechanism and cannot be used to break the usual rules of grammar, type, and scope. For example:

```

template<typename T>
void bad(T arg)
{
    if constexpr(Something<T>::value)
        try {                                // syntax error

        g(arg);

        if constexpr(Something<T>::value)
            } catch(...) { /* ... */ }      // syntax error
}

```

Allowing such text manipulation could seriously compromise readability of code and create problems for tools relying on modern program representation techniques (such as “abstract syntax trees”).

6.5 Advice

- [1] Use templates to express algorithms that apply to many argument types; §6.1; [CG: T.2].
- [2] Use templates to express containers; §6.2; [CG: T.3].
- [3] Use templates to raise the level of abstraction of code; §6.2; [CG: T.1].
- [4] Templates are type safe, but checking happens too late; §6.2.
- [5] Let constructors or function templates deduce class template argument types; §6.2.3.
- [6] Use function objects as arguments to algorithms; §6.3.2; [CG: T.40].
- [7] Use a lambda if you need a simple function object in one place only; §6.3.2.
- [8] A virtual function member cannot be a template member function; §6.3.1.
- [9] Use template aliases to simplify notation and hide implementation details; §6.4.2.
- [10] To use a template, make sure its definition (not just its declaration) is in scope; §7.5.
- [11] Templates offer compile-time “duck typing”; §7.5.
- [12] There is no separate compilation of templates: `#include` template definitions in every translation unit that uses them.

Concepts and Generic Programming

*Programming:
you have to start with interesting algorithms.
– Alex Stepanov*

- Introduction
- Concepts
 - Use of Concepts; Concept-Based Overloading; Valid Code; Definition of Concepts
- Generic Programming
 - Use of Concepts; Abstraction Using Templates
- Variadic Templates
 - Fold Expressions; Forwarding Arguments
- Template Compilation Model
- Advice

7.1 Introduction

What are templates for? In other words, what programming techniques are effective when you use templates? Templates offer:

- The ability to pass types (as well as values and templates) as arguments without loss of information. This implies excellent opportunities for inlining, of which current implementations take great advantage.
- Opportunities to weave together information from different contexts at instantiation time. This implies optimization opportunities.
- The ability to pass constant values as arguments. This implies the ability to do compile-time computation.

In other words, templates provide a powerful mechanism for compile-time computation and type manipulation that can lead to very compact and efficient code. Remember that types (classes) can contain both code (§6.3.2) and values (§6.2.2).

The first and most common use of templates is to support *generic programming*, that is, programming focused on the design, implementation, and use of general algorithms. Here, “general” means that an algorithm can be designed to accept a wide variety of types as long as they meet the algorithm’s requirements on its arguments. Together with concepts, the template is C++’s main support for generic programming. Templates provide (compile-time) parametric polymorphism.

7.2 Concepts (C++20)

Consider the `sum()` from §6.3.1:

```
template<typename Seq, typename Num>
Num sum(Seq s, Num v)
{
    for (const auto& x : s)
        v+=x;
    return v;
}
```

It can be invoked for any data structure that supports `begin()` and `end()` so that the range-`for` will work. Such structures include the standard-library `vector`, `list`, and `map`. Furthermore, the element type of the data structure is limited only by its use: it must be a type that we can add to the `Value` argument. Examples are `ints`, `doubles`, and `Matrixes` (for any reasonable definition of `Matrix`). We could say that the `sum()` algorithm is generic in two dimensions: the type of the data structure used to store elements (“the sequence”) and the type of elements.

So, `sum()` requires that its first template argument is some kind of sequence and its second template argument is some kind of number. We call such requirements *concepts*.

Language support for concepts is not yet ISO C++, but it is an ISO Technical Specification [ConceptsTS]. Implementations are in use, so I risk recommending it here even though details are likely to change and it may be years before everybody can use it in production code.

7.2.1 Use of Concepts

Most template arguments must meet specific requirements for the template to compile properly and for the generated code to work properly. That is, most templates must be constrained templates (§6.2.1). The type-name introducer `typename` is the least constraining, requiring only that the argument be a type. Usually, we can do better than that. Consider that `sum()` again:

```
template<Sequence Seq, Number Num>
Num sum(Seq s, Num v)
{
    for (const auto& x : s)
        v+=x;
    return v;
}
```

That’s much clearer. Once we have defined what the concepts `Sequence` and `Number` mean, the compiler can reject bad calls by looking at `sum()`’s interface only, rather than looking at its implementation. This improves error reporting.

However, the specification of `sum()`'s interface is not complete: I “forgot” to say that we should be able to add elements of a `Sequence` to a `Number`. We can do that:

```
template<Sequence Seq, Number Num>
    requires Arithmetic<Value_type<Seq>,Num>
    Num sum(Seq s, Num n);
```

The `Value_type` of a sequence is the type of the elements in the sequence. `Arithmetic<X,Y>` is a concept specifying that we can do arithmetic with numbers of types `X` and `Y`. This saves us from accidentally trying to calculate the `sum()` of a `vector<string>` or a `vector<int*>` while still accepting `vector<int>` and `vector<complex<double>>`.

In this example, we needed only `+=`, but for simplicity and flexibility, we should not constrain our template argument too tightly. In particular, we might someday want to express `sum()` in terms of `+` and `=` rather than `+=`, and then we'd be happy that we used a general concept (here, `Arithmetic`) rather than a narrow requirement to “have `+=`.”

Partial specifications, as in the first `sum()` using concepts, can be very useful. Unless the specification is complete, some errors will not be found until instantiation time. However, partial specifications can help a lot, express intent, and are essential for smooth incremental development where we don't initially recognize all the requirements we need. With mature libraries of concepts, initial specifications will be close to perfect.

Unsurprisingly, `requires Arithmetic<Value_type<Seq>,Num>` is called a `requirements`-clause. The `template<Sequence Seq>` notation is simply a shorthand for an explicit use of `requires Sequence<Seq>`. If I liked verbosity, I could equivalently have written

```
template<typename Seq, typename Num>
    requires Sequence<Seq> && Number<Num> && Arithmetic<Value_type<Seq>,Num>
    Num sum(Seq s, Num n);
```

On the other hand, we could also use the equivalence between the two notations to write:

```
template<Sequence Seq, Arithmetic<Value_type<Seq>> Num>
    Num sum(Seq s, Num n);
```

Where we cannot yet use concepts, we have to make do with naming conventions and comments, such as:

```
template<typename Sequence, typename Number>
    // requires Arithmetic<Value_type<Sequence>,Number>
    Numer sum(Sequence s, Number n);
```

Whatever notation we chose, it is important to design a template with semantically meaningful constraints on its arguments (§7.2.4).

7.2.2 Concept-based Overloading

Once we have properly specified templates with their interfaces, we can overload based on their properties, much as we do for functions. Consider a slightly simplified standard-library function `advance()` that advances an iterator (§12.3):

```

template<Forward_iterator Iter>
void advance(Iter p, int n)           // move p n elements forward
{
    while (n-->0)
        ++p;           // a forward iterator has ++, but not + or +=
}

template<Random_access_iterator Iter>
void advance(Iter p, int n)           // move p n elements forward
{
    p+=n;           // a random-access iterator has +=
}

```

The compiler will select the template with the strongest requirements met by the arguments. In this case, a `list` only supplies forward iterators, but a `vector` offers random-access iterators, so we get:

```

void user(vector<int>::iterator vip, list<string>::iterator lsp)
{
    advance(vip,10); // use the fast advance()
    advance(lsp,10); // use the slow advance()
}

```

Like other overloading, this is a compile-time mechanism implying no run-time cost, and where the compiler does not find a best choice, it gives an ambiguity error. The rules for concept-based overloading are far simpler than the rules for general overloading (§1.3). Consider first a single argument for several alternative functions:

- If the argument doesn't match the concept, that alternative cannot be chosen.
- If the argument matches the concept for just one alternative, that alternative is chosen.
- If arguments from two alternatives are equally good matches for a concept, we have an ambiguity.
- If arguments from two alternatives match a concept and one is stricter than the other (match all the requirements of the other and more), that alternative is chosen.

For an alternative to be chosen it has to be

- a match for all of its arguments, and
- at least an equally good match for all arguments as other alternatives, and
- a better match for at least one argument.

7.2.3 Valid Code

The question of whether a set of template arguments offers what a template requires of its template parameters ultimately boils down to whether some expressions are valid.

Using a `requires`-expression, we can check if a set of expressions is valid. For example:

```

template<Forward_iterator Iter>
void advance(Iter p, int n)           // move p n elements forward
{
    while (n-->0)
        ++p;           // a forward iterator has ++, but not + or +=
}

```

```

template<Forward_iterator Iter, int n>
    requires requires(Iter p, int i) { p[i]; p++; }    // Iter has subscripting and addition
void advance(Iter p, int n)                          // move p n elements forward
{
    p+=n;      // a random-access iterator has +=
}

```

No, that `requires requires` is not a typo. The first `requires` starts the `requirements`-clause and the second `requires` starts the `requires-expression`

```
requires(Iter p, int i) { p[i]; p++; }
```

A `requires-expression` is a predicate that is `true` if the statements in it are valid code and `false` if they are not.

I consider `requires`-expressions the assembly code of generic programming. Like ordinary assembly code, `requires`-expressions are extremely flexible and impose no programming discipline. In some form or other, they are at the bottom of most interesting generic code, just as assembly code is at the bottom of most interesting ordinary code. Like assembly code, `requires`-expressions should not be seen in “ordinary code.” If you see `requires requires` in your code, it is probably too low level.

The use of `requires requires` in `advance()` is deliberately inelegant and hackish. Note that I “forgot” to specify `+=` and the required return types for the operations. You have been warned! Prefer named concepts for which the name indicates its semantic meaning.

Prefer use of properly named concepts with well-specified semantics (§7.2.4) and use `requires`-expressions in the definition of those.

7.2.4 Definition of Concepts

Eventually, we expect to find useful concepts, such as `Sequence` and `Arithmetic` in libraries, including the standard library. The Ranges Technical Specification [RangesTS] already offers a set for constraining standard-library algorithms (§12.7). However, simple concepts are not hard to define.

A concept is a compile-time predicate specifying how one or more types can be used. Consider first one of the simplest examples:

```

template<typename T>
concept Equality_comparable =
    requires (T a, T b) {
        { a == b } -> bool; // compare Ts with ==
        { a != b } -> bool; // compare Ts with !=
    };

```

`Equality_comparable` is the concept we use to ensure that we can compare values of a type equal and non-equal. We simply say that, given two values of the type, they must be comparable using `==` and `!=` and the result of those operations must be convertible to `bool`. For example:

```

static_assert(Equality_comparable<int>); // succeeds

struct S { int a; };
static_assert(Equality_comparable<S>); // fails because structs don't automatically get == and !=

```

The definition of the concept `Equality_comparable` is exactly equivalent to the English description and no longer. The value of a `concept` is always `bool`.

Defining `Equality_comparable` to handle nonhomogeneous comparisons is almost as easy:

```
template<typename T, typename T2 =T>
concept Equality_comparable =
    requires (T a, T2 b) {
        { a == b } -> bool; // compare a T to a T2 with ==
        { a != b } -> bool; // compare a T to a T2 with !=
        { b == a } -> bool; // compare a T2 to a T with ==
        { b != a } -> bool; // compare a T2 to a T with !=
    };
```

The `typename T2 =T` says that if we don't specify a second template argument, `T2` will be the same as `T`; `T` is a *default template argument*.

We can test `Equality_comparable` like this:

```
static_assert(Equality_comparable<int,double>); // succeeds
static_assert(Equality_comparable<int>);       // succeeds (T2 is defaulted to int)
static_assert(Equality_comparable<int,string>); // fails
```

For a more complex example, consider a sequence:

```
template<typename S>
concept Sequence = requires(S a) {
    typename Value_type<S>; // S must have a value type.
    typename Iterator_type<S>; // S must have an iterator type.

    { begin(a) } -> Iterator_type<S>; // begin(a) must return an iterator
    { end(a) } -> Iterator_type<S>; // end(a) must return an iterator

    requires Same_type<Value_type<S>,Value_type<Iterator_type<S>>>;
    requires Input_iterator<Iterator_type<S>>;
};
```

For a type `S` to be a `Sequence`, it must provide a `Value_type` (the type of its elements) and an `Iterator_type` (the type of its iterators; see §12.1). It must also ensure that there exist `begin()` and `end()` functions that return iterators, as is idiomatic for standard-library containers (§11.3). Finally, the `Iterator_type` really must be an `input_iterator` with elements of the same type as the elements of `S`.

The hardest concepts to define are the ones that represent fundamental language concepts. Consequently, it is best to use a set from an established library. For a useful collection, see §12.7.

7.3 Generic Programming

The form of *generic programming* supported by C++ centers around the idea of abstracting from concrete, efficient algorithms to obtain generic algorithms that can be combined with different data representations to produce a wide variety of useful software [Stepanov,2009]. The abstractions representing the fundamental operations and data structures are called *concepts*; they appear as requirements for template parameters.

7.3.1 Use of Concepts

Good, useful concepts are fundamental and are discovered more than they are designed. Examples are integer and floating-point number (as defined even in Classic C), sequence, and more general mathematical concepts, such as field and vector space. They represent the fundamental concepts of a field of application. That is why they are called “concepts.” Identifying and formalizing concepts to the degree necessary for effective generic programming can be a challenge.

For basic use, consider the concept **Regular** (§12.7). A type is regular when it behaves much like an **int** or a **vector**. An object of a regular type

- can be default constructed.
- can be copied (with the usual semantics of copy, yielding two objects that are independent and compare equal) using a constructor or an assignment.
- can be compared using `==` and `!=`.
- doesn’t suffer technical problems from overly clever programming tricks.

A **string** is another example of a regular type. Like **int**, **string** is also **StrictTotallyOrdered** (§12.7). That is, two strings can be compared using `<`, `<=`, `>`, and `>=` with the appropriate semantics.

A concept is not just a syntactic notion, it is fundamentally about semantics. For example, don’t define `+` to divide; that would not match the requirements for any reasonable number. Unfortunately, we do not yet have any language support for expressing semantics, so we have to rely on expert knowledge and common sense to get semantically meaningful concepts. Do not define semantically meaningless concepts, such as **Addable** and **Subtractable**. Instead, rely on domain knowledge to define concepts that match fundamental concepts in an application domain.

7.3.2 Abstraction Using Templates

Good abstractions are carefully grown from concrete examples. It is not a good idea to try to “abstract” by trying to prepare for every conceivable need and technique; in that direction lies inelegance and code bloat. Instead, start with one – and preferably more – concrete examples from real use and try to eliminate inessential details. Consider:

```
double sum(const vector<int>& v)
{
    double res = 0;
    for (auto x : v)
        res += x;
    return res;
}
```

This is obviously one of many ways to compute the sum of a sequence of numbers.

Consider what makes this code less general than it needs to be:

- Why just **ints**?
- Why just **vectors**?
- Why accumulate in a **double**?
- Why start at **0**?
- Why add?

Answering the first four questions by making the concrete types into template arguments, we get the simplest form of the standard-library **accumulate** algorithm:

```

template<typename Iter, typename Val>
Val accumulate(Iter first, Iter last, Val res)
{
    for (auto p = first; p!=last; ++p)
        res += *p;
    return res;
}

```

Here, we have:

- The data structure to be traversed has been abstracted into a pair of iterators representing a sequence (§12.1).
- The type of the accumulator has been made into a parameter.
- The initial value is now an input; the type of the accumulator is the type of this initial value.

A quick examination or – even better – measurement will show that the code generated for calls with a variety of data structures is identical to what you get from the hand-coded original example. For example:

```

void use(const vector<int>& vec, const list<double>& lst)
{
    auto sum = accumulate(begin(vec),end(vec),0.0); // accumulate in a double
    auto sum2 = accumulate(begin(lst),end(lst),sum);
    //
}

```

The process of generalizing from a concrete piece of code (and preferably from several) while preserving performance is called *lifting*. Conversely, the best way to develop a template is often to

- first, write a concrete version
- then, debug, test, and measure it
- finally, replace the concrete types with template arguments.

Naturally, the repetition of `begin()` and `end()` is tedious, so we can simplify the user interface a bit:

```

template<Range R, Number Val> // a Range is something with begin() and end()
Val accumulate(const R& r, Val res = 0)
{
    for (auto p = begin(r); p!=end(r); ++p)
        res += *p;
    return res;
}

```

For full generality, we can abstract the `+=` operation also; see §14.3.

7.4 Variadic Templates

A template can be defined to accept an arbitrary number of arguments of arbitrary types. Such a template is called a *variadic template*. Consider a simple function to write out values of any type that has a `<<` operator:

```

void user()
{
    print("first: ", 1, 2.2, "hello\n"s);           // first: 1 2.2 hello

    print("\nsecond: ", 0.2, 'c', "yuck!\n"s, 0, 1, 2, '\n'); // second: 0.2 c yuck! 0 1 2
}

```

Traditionally, implementing a variadic template has been to separate the first argument from the rest and then recursively call the variadic template for the tail of the arguments:

```

void print()
{
    // what we do for no arguments: nothing
}

template<typename T, typename... Tail>
void print(T head, Tail... tail)
{
    // what we do for each argument, e.g.,
    cout << head << ' ';
    print(tail...);
}

```

The `typename...` indicates that `Tail` is a sequence of types. The `Tail...` indicates that `tail` is a sequence of values of the types in `Tail`. A parameter declared with a `...` is called a *parameter pack*. Here, `tail` is a (function argument) parameter pack where the elements are of the types found in the (template argument) parameter pack `Tail`. So, `print()` can take any number of arguments of any types.

A call of `print()` separates the arguments into a head (the first) and a tail (the rest). The head is printed and then `print()` is called for the tail. Eventually, of course, `tail` will become empty, so we need the no-argument version of `print()` to deal with that. If we don't want to allow the zero-argument case, we can eliminate that `print()` using a compile-time `if`:

```

template<typename T, typename... Tail>
void print(T head, Tail... tail)
{
    cout << head << ' ';
    if constexpr(sizeof...(tail) > 0)
        print(tail...);
}

```

I used a compile-time `if` (§6.4.3), rather than a plain run-time `if` to avoid a final, never called, call `print()` from being generated.

The strength of variadic templates (sometimes just called *variadics*) is that they can accept any arguments you care to give them. Weaknesses include

- The recursive implementations can be tricky to get right.
- The recursive implementations can be surprisingly expensive in compile time.
- The type checking of the interface is a possibly elaborate template program.

Because of their flexibility, variadic templates are widely used in the standard library, and occasionally wildly overused.

7.4.1 Fold Expressions

To simplify the implementation of simple variadic templates, C++17 offers a limited form of iteration over elements of a parameter pack. For example:

```
template<Number... T>
int sum(T... v)
{
    return (v + ... + 0);    // add all elements of v starting with 0
}
```

Here, `sum()` can take any number of arguments of any types. Assuming that `sum()` really adds its arguments, we get:

```
int x = sum(1, 2, 3, 4, 5); // x becomes 15
int y = sum('a', 2.4, x);  // y becomes 114 (2.4 is truncated and the value of 'a' is 97)
```

The body of `sum` uses a fold expression:

```
return (v + ... + 0); // add all elements of v to 0
```

Here, `(v+...+0)` means add all the elements of `v` starting with the initial value `0`. The first element to be added is the “rightmost” (the one with the highest index): `(v[0]+(v[1]+(v[2]+(v[3]+(v[4]+0)))))`. That is, starting from the right where the `0` is. It is called a *right fold*. Alternatively, we could have used a *left fold*:

```
template<Number... T>
int sum2(T... v)
{
    return (0 + ... + v); // add all elements of v to 0
}
```

Now, the first element to be added is the “leftmost” (the one with the lowest index): `((((0+v[0])+v[1])+v[2])+v[3])+v[4])`. That is, starting from the left where the `0` is.

Fold is a very powerful abstraction, clearly related to the standard-library `accumulate()`, with a variety of names in different languages and communities. In C++, the fold expressions are currently restricted to simplify the implementation of variadic templates. A fold does not have to perform numeric computations. Consider a famous example:

```
template<typename ...T>
void print(T&&... args)
{
    (std::cout << ... << args) << '\n'; // print all arguments
}

print("Hello!"s, ' ', "World ", 2017); // (((std::cout << "Hello!"s) << ' ') << "World ") << 2017) << '\n';
```

Many use cases simply involve a set of values that can be converted to a common type. In such cases, simply copying the arguments into a vector or the desired type often simplifies further use:

```

template<typename Res, typename... Ts>
vector<Res> to_vector(Ts&&... ts)
{
    vector<Res> res;
    (res.push_back(ts) ...); // no initial value needed
    return res;
}

```

We can use `to_vector` like this:

```

auto x = to_vector<double>(1,2,4.5,'a');

template<typename... Ts>
int fct(Ts&&... ts)
{
    auto args = to_vector<string>(ts...); // args[i] is the ith argument
    // ... use args here ...
}

int y = fct("foo", "bar", s);

```

7.4.2 Forwarding Arguments

Passing arguments unchanged through an interface is an important use of variadic templates. Consider a notion of a network input channel for which the actual method of moving values is a parameter. Different transport mechanisms have different sets of constructor parameters:

```

template<typename Transport>
requires concepts::InputTransport<Transport>
class InputChannel {
public:
    // ...
    InputChannel(TransportArgs&&... transportArgs)
        : _transport(std::forward<TransportArgs>(transportArgs)...)
    {}
    // ...
    Transport _transport;
};

```

The standard-library function `forward()` (§13.2.2) is used to move the arguments unchanged from the `InputChannel` constructor to the `Transport` constructor.

The point here is that the writer of `InputChannel` can construct an object of type `Transport` without having to know what arguments are required to construct a particular `Transport`. The implementer of `InputChannel` needs only to know the common user interface for all `Transport` objects.

Forwarding is very common in foundational libraries where generality and low run-time overhead are necessary and very general interfaces are common.

7.5 Template Compilation Model

Assuming concepts (§7.2), the arguments for a template are checked against its concepts. Errors found here will be reported and the programmer has to fix the problems. What cannot be checked at this point, such as arguments for unconstrained template arguments, is postponed until code is generated for the template and a set of template arguments: “at template instantiation time.” For pre-concept code, this is where all type checking happens. When using concepts, we get here only after concept checking succeeded.

An unfortunate side effect of instantiation-time (late) type checking is that a type error can be found uncomfortably late and can result in spectacularly bad error messages because the compiler found the problem only after combining information from several places in the program.

The instantiation-time type checking provided for templates checks the use of arguments in the template definition. This provides a compile-time variant of what is often called *duck typing* (“If it walks like a duck and it quacks like a duck, it’s a duck”). Or – using more technical terminology – we operate on values, and the presence and meaning of an operation depend solely on its operand values. This differs from the alternative view that objects have types, which determine the presence and meaning of operations. Values “live” in objects. This is the way objects (e.g., variables) work in C++, and only values that meet an object’s requirements can be put into it. What is done at compile time using templates mostly does not involve objects, only values. The exception is local variables in a `constexpr` function (§1.6) that are used as objects inside the compiler.

To use an unconstrained template, its definition (not just its declaration) must be in scope at its point of use. For example, the standard header `<vector>` holds the definition of `vector`. In practice, this means that template definitions are typically found in header files, rather than `.cpp` files. This changes when we start to use modules (§3.3). Using modules, the source code is organized in the same way for ordinary functions and template functions. In both cases, definitions will be protected against the problems of textual inclusion.

7.6 Advice

- [1] Templates provide a general mechanism for compile-time programming; §7.1.
- [2] When designing a template, carefully consider the concepts (requirements) assumed for its template arguments; §7.3.2.
- [3] When designing a template, use a concrete version for initial implementation, debugging, and measurement; §7.3.2.
- [4] Use concepts as a design tool; §7.2.1.
- [5] Specify concepts for all template arguments; §7.2; [CG: T.10].
- [6] Whenever possible use standard concepts (e.g., the Ranges concepts); §7.2.4; [CG: T.11].
- [7] Use a lambda if you need a simple function object in one place only; §6.3.2.
- [8] There is no separate compilation of templates: `#include` template definitions in every translation unit that uses them.
- [9] Use templates to express containers and ranges; §7.3.2; [CG: T.3].
- [10] Avoid “concepts” without meaningful semantics; §7.2; [CG: T.20].
- [11] Require a complete set of operations for a concept; §7.2; [CG: T.21].

- [12] Use variadic templates when you need a function that takes a variable number of arguments of a variety of types; §7.4.
- [13] Don't use variadic templates for homogeneous argument lists (prefer initializer lists for that); §7.4.
- [14] To use a template, make sure its definition (not just its declaration) is in scope; §7.5.
- [15] Templates offer compile-time “duck typing”; §7.5.

This page intentionally left blank

Library Overview

*Why waste time learning
when ignorance is instantaneous?
– Hobbes*

- Introduction
- Standard-Library Components
- Standard-Library Headers and Namespace
- Advice

8.1 Introduction

No significant program is written in just a bare programming language. First, a set of libraries is developed. These then form the basis for further work. Most programs are tedious to write in the bare language, whereas just about any task can be rendered simple by the use of good libraries.

Continuing from Chapters 1–7, Chapters 9–15 give a quick tour of key standard-library facilities. I very briefly present useful standard-library types, such as **string**, **ostream**, **variant**, **vector**, **map**, **path**, **unique_ptr**, **thread**, **regex**, and **complex**, as well as the most common ways of using them.

As in Chapters 1–7, you are strongly encouraged not to be distracted or discouraged by an incomplete understanding of details. The purpose of this chapter is to convey a basic understanding of the most useful library facilities.

The specification of the standard library is over two thirds of the ISO C++ standard. Explore it, and prefer it to home-made alternatives. Much thought has gone into its design, more still into its implementations, and much effort will go into its maintenance and extension.

The standard-library facilities described in this book are part of every complete C++ implementation. In addition to the standard-library components, most implementations offer “graphical user interface” systems (GUIs), Web interfaces, database interfaces, etc. Similarly, most application-development environments provide “foundation libraries” for corporate or industrial “standard” development and/or execution environments. Here, I do not describe such systems and libraries.

The intent is to provide a self-contained description of C++ as defined by the standard and to keep the examples portable. Naturally, a programmer is encouraged to explore the more extensive facilities available on most systems.

8.2 Standard-Library Components

The facilities provided by the standard library can be classified like this:

- Run-time language support (e.g., for allocation and run-time type information).
- The C standard library (with very minor modifications to minimize violations of the type system).
- Strings (with support for international character sets, localization, and read-only views of substrings); see §9.2.
- Support for regular expression matching; see §9.4.
- I/O streams is an extensible framework for input and output to which users can add their own types, streams, buffering strategies, locales, and character sets (Chapter 10). There is also a library for manipulating file systems in a portable manner (§10.10).
- A framework of containers (such as **vector** and **map**) and algorithms (such as **find()**, **sort()**, and **merge()**); see Chapter 11 and Chapter 12. This framework, conventionally called the STL [Stepanov,1994], is extensible so users can add their own containers and algorithms.
- Support for numerical computation (such as standard mathematical functions, complex numbers, vectors with arithmetic operations, and random number generators); see §4.2.1 and Chapter 14.
- Support for concurrent programming, including **threads** and locks; see Chapter 15. The concurrency support is foundational so that users can add support for new models of concurrency as libraries.
- Parallel versions of most STL algorithms and some numerical algorithms (e.g., **sort()** and **reduce()**); see §12.9 and §14.3.1.
- Utilities to support template metaprogramming (e.g., type traits; §13.9), STL-style generic programming (e.g., **pair**; §13.4.3), general programming (e.g., **variant** and **optional**; §13.5.1, §13.5.2), and **clock** (§13.7).
- Support for efficient and safe management of general resources, plus an interface to optional garbage collectors (§5.3).
- “Smart pointers” for resource management (e.g., **unique_ptr** and **shared_ptr**; §13.2.1).
- Special-purpose containers, such as **array** (§13.4.1), **bitset** (§13.4.2), and **tuple** (§13.4.3).
- Suffixes for popular units, such as **ms** for milliseconds and **i** for imaginary (§5.4.4).

The main criteria for including a class in the library were that:

- it could be helpful to almost every C++ programmer (both novices and experts),
- it could be provided in a general form that did not add significant overhead compared to a simpler version of the same facility, and
- simple uses should be easy to learn (relative to the inherent complexity of their task).

Essentially, the C++ standard library provides the most common fundamental data structures together with the fundamental algorithms used on them.

8.3 Standard-Library Headers and Namespace

Every standard-library facility is provided through some standard header. For example:

```
#include<string>
#include<list>
```

This makes the standard `string` and `list` available.

The standard library is defined in a namespace (§3.4) called `std`. To use standard-library facilities, the `std::` prefix can be used:

```
std::string sheep {"Four legs Good; two legs Baaad!"};
std::list<std::string> slogans {"War is Peace", "Freedom is Slavery", "Ignorance is Strength"};
```

For simplicity, I will rarely use the `std::` prefix explicitly in examples. Neither will I always `#include` the necessary headers explicitly. To compile and run the program fragments here, you must `#include` the appropriate headers and make the names they declare accessible. For example:

```
#include<string>           // make the standard string facilities accessible
using namespace std;      // make std names available without std:: prefix
```

```
string s {"C++ is a general-purpose programming language"}; // OK: string is std::string
```

It is generally in poor taste to dump every name from a namespace into the global namespace. However, in this book, I use the standard library exclusively and it is good to know what it offers.

Here is a selection of standard-library headers, all supplying declarations in namespace `std`:

Selected Standard Library Headers		
<code><algorithm></code>	<code>copy()</code> , <code>find()</code> , <code>sort()</code>	Chapter 12
<code><array></code>	<code>array</code>	§13.4.1
<code><chrono></code>	<code>duration</code> , <code>time_point</code>	§13.7
<code><cmath></code>	<code>sqrt()</code> , <code>pow()</code>	§14.2
<code><complex></code>	<code>complex</code> , <code>sqrt()</code> , <code>pow()</code>	§14.4
<code><filesystem></code>	<code>path</code>	§10.10
<code><forward_list></code>	<code>forward_list</code>	§11.6
<code><fstream></code>	<code>fstream</code> , <code>ifstream</code> , <code>ofstream</code>	§10.7
<code><future></code>	<code>future</code> , <code>promise</code>	§15.7
<code><ios></code>	<code>hex</code> , <code>dec</code> , <code>scientific</code> , <code>fixed</code> , <code>defaultfloat</code>	§10.6
<code><iostream></code>	<code>istream</code> , <code>ostream</code> , <code>cin</code> , <code>cout</code>	Chapter 10
<code><map></code>	<code>map</code> , <code>multimap</code>	§11.5
<code><memory></code>	<code>unique_ptr</code> , <code>shared_ptr</code> , <code>allocator</code>	§13.2.1
<code><random></code>	<code>default_random_engine</code> , <code>normal_distribution</code>	§14.5
<code><regex></code>	<code>regex</code> , <code>smatch</code>	§9.4
<code><string></code>	<code>string</code> , <code>basic_string</code>	§9.2
<code><set></code>	<code>set</code> , <code>multiset</code>	§11.6
<code><sstream></code>	<code>istringstream</code> , <code>ostringstream</code>	§10.8

Selected Standard Library Headers (Continued)		
<code><stdexcept></code>	<code>length_error</code> , <code>out_of_range</code> , <code>runtime_error</code>	§3.5.1
<code><thread></code>	<code>thread</code>	§15.2
<code><unordered_map></code>	<code>unordered_map</code> , <code>unordered_multimap</code>	§11.5
<code><utility></code>	<code>move()</code> , <code>swap()</code> , <code>pair</code>	Chapter 13
<code><variant></code>	<code>variant</code>	§13.5.1
<code><vector></code>	<code>vector</code>	§11.2

This listing is far from complete.

Headers from the C standard library, such as `<stdlib.h>` are provided. For each such header there is also a version with its name prefixed by `c` and the `.h` removed. This version, such as `<cstdlib>` places its declarations in the `std` namespace.

8.4 Advice

- [1] Don't reinvent the wheel; use libraries; §8.1; [CG: SL.1.]
- [2] When you have a choice, prefer the standard library over other libraries; §8.1; [CG: SL.2].
- [3] Do not think that the standard library is ideal for everything; §8.1.
- [4] Remember to `#include` the headers for the facilities you use; §8.3.
- [5] Remember that standard-library facilities are defined in namespace `std`; §8.3; [CG: SL.3].

Strings and Regular Expressions

*Prefer the standard to the offbeat.
– Strunk & White*

- Introduction
- Strings
 - `string` Implementation;
- String Views
- Regular Expressions
 - Searching; Regular Expression Notation; Iterators
- Advice

9.1 Introduction

Text manipulation is a major part of most programs. The C++ standard library offers a `string` type to save most users from C-style manipulation of arrays of characters through pointers. A `string_view` type allows us to manipulate sequences of characters however they may be stored (e.g., in a `std::string` or a `char[]`). In addition, regular expression matching is offered to help find patterns in text. The regular expressions are provided in a form similar to what is common in most modern languages. Both `strings` and `regex` objects can use a variety of character types (e.g., Unicode).

9.2 Strings

The standard library provides a `string` type to complement the string literals (§1.2.1); `string` is a **Regular** type (§7.2, §12.7) for owning and manipulating a sequence of characters of various character types. The `string` type provides a variety of useful string operations, such as concatenation. For example:

```
string compose(const string& name, const string& domain)
{
    return name + '@' + domain;
}
```

```
auto addr = compose("dmr", "bell-labs.com");
```

Here, `addr` is initialized to the character sequence `dmr@bell-labs.com`. “Addition” of `strings` means concatenation. You can concatenate a `string`, a string literal, a C-style string, or a character to a `string`. The standard `string` has a move constructor, so returning even long `strings` by value is efficient (§5.2.2).

In many applications, the most common form of concatenation is adding something to the end of a `string`. This is directly supported by the `+=` operation. For example:

```
void m2(string& s1, string& s2)
{
    s1 = s1 + '\n'; // append newline
    s2 += '\n';    // append newline
}
```

The two ways of adding to the end of a `string` are semantically equivalent, but I prefer the latter because it is more explicit about what it does, more concise, and possibly more efficient.

A `string` is mutable. In addition to `=` and `+=`, subscripting (using `[]`) and substring operations are supported. For example:

```
string name = "Niels Stroustrup";

void m3()
{
    string s = name.substr(6,10); // s = "Stroustrup"
    name.replace(0,5,"nicholas"); // name becomes "nicholas Stroustrup"
    name[0] = toupper(name[0]); // name becomes "Nicholas Stroustrup"
}
```

The `substr()` operation returns a `string` that is a copy of the substring indicated by its arguments. The first argument is an index into the `string` (a position), and the second is the length of the desired substring. Since indexing starts from `0`, `s` gets the value `Stroustrup`.

The `replace()` operation replaces a substring with a value. In this case, the substring starting at `0` with length `5` is `Niels`; it is replaced by `nicholas`. Finally, I replace the initial character with its uppercase equivalent. Thus, the final value of `name` is `Nicholas Stroustrup`. Note that the replacement string need not be the same size as the substring that it is replacing.

Among the many useful `string` operations are assignment (using `=`), subscripting (using `[]` or `at()` as for `vector`; §11.2.2), comparison (using `==` and `!=`), and lexicographical ordering (using `<`, `<=`, `>`, and `>=`), iteration (using iterators as for `vector`; §12.2), input (§10.3), and streaming (§10.8).

Naturally, `strings` can be compared against each other, against C-style strings (§1.7.1), and against string literals. For example:

```

string incantation;

void respond(const string& answer)
{
    if (answer == incantation) {
        // perform magic
    }
    else if (answer == "yes") {
        // ...
    }
    // ...
}

```

If you need a C-style string (a zero-terminated array of `char`), `string` offers read-only access to its contained characters. For example:

```

void print(const string& s)
{
    printf("For people who like printf: %s\n", s.c_str());    // s.c_str() returns a pointer to s' characters
    cout << "For people who like streams: " << s << '\n';
}

```

A string literal is by definition a `const char*`. To get a literal of type `std::string` use a `s` suffix. For example:

```

auto s = "Cat"s;    // a std::string
auto p = "Dog";    // a C-style string: a const char*

```

To use the `s` suffix, you need to use the namespace `std::literals::string_literals` (§5.4.4).

9.2.1 string Implementation

Implementing a string class is a popular and useful exercise. However, for general-purpose use, our carefully crafted first attempts rarely match the standard `string` in convenience or performance. These days, `string` is usually implemented using the *short-string optimization*. That is, short string values are kept in the `string` object itself and only longer strings are placed on free store. Consider:

```

string s1 {"Annemarie"};    // short string
string s2 {"Annemarie Stroustrup"};    // long string

```

The memory layout will be something like this:

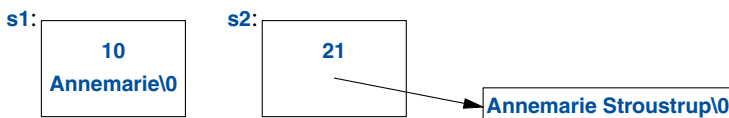

When a `string`'s value changes from a short to a long string (and vice versa) its representation adjusts appropriately. How many characters can a “short” string have? That’s implementation defined, but “about 14 characters” isn’t a bad guess.

The actual performance of **strings** can depend critically on the run-time environment. In particular, in multi-threaded implementations, memory allocation can be relatively costly. Also, when lots of strings of differing lengths are used, memory fragmentation can result. These are the main reasons that the short-string optimization has become ubiquitous.

To handle multiple character sets, **string** is really an alias for a general template **basic_string** with the character type **char**:

```
template<typename Char>
class basic_string {
    // ... string of Char ...
};
```

```
using string = basic_string<char>;
```

A user can define strings of arbitrary character types. For example, assuming we have a Japanese character type **Jchar**, we can write:

```
using Jstring = basic_string<Jchar>;
```

Now we can do all the usual string operations on **Jstring**, a string of Japanese characters.

9.3 String Views

The most common use of a sequence of characters is to pass it to some function to read. This can be achieved by passing a **string** by value, a reference to a string, or a C-style string. In many systems there are further alternatives, such as string types not offered by the standard. In all of these cases, there are extra complexities when we want to pass a substring. To address this, the standard library offers **string_view**; a **string_view** is basically a (pointer,length) pair denoting a sequence of characters:

```
string_view:           { begin() , size() }
```

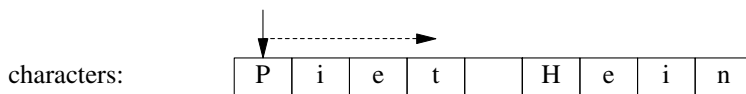

A **string_view** gives access to a contiguous sequence of characters. The characters can be stored in many possible ways, including in a **string** and in a C-style string. A **string_view** is like a pointer or a reference in that it does not own the characters it points to. In that, it resembles an STL pair of iterators (§12.3).

Consider a simple function concatenating two strings:

```
string cat(string_view sv1, string_view sv2)
{
    string res(sv1.length()+sv2.length());
    char* p = &res[0];
    for (char c : sv1)                // one way to copy
        *p++ = c;
    copy(sv2.begin(),sv2.end(),p);    // another way
    return res;
}
```

We can call this `cat()`:

```
string king = "Harold";
auto s1 = cat(king,"William");        // string and const char*
auto s2 = cat(king,king);             // string and string
auto s3 = cat("Edward","Stephen"sv); // const char * and string_view
auto s4 = cat("Canute"sv,king);
auto s5 = cat({&king[0],2},"Henry"sv); // HaHenry
auto s6 = cat({&king[0],2},{&king[2],4}); // Harold
```

This `cat()` has three advantages over the `compose()` that takes `const string&` arguments (§9.2):

- It can be used for character sequences managed in many different ways.
- No temporary `string` arguments are created for C-style string arguments.
- We can easily pass substrings.

Note the use of the `sv` (“string view”) suffix. To use that we need to

```
using namespace std::literals::string_view_literals; // §5.4.4
```

Why bother? The reason is that when we pass `"Edward"` we need to construct a `string_view` from a `const char*` and that requires counting the characters. For `"Stephen"sv` the length is computed at compile time.

When returning a `string_view`, remember that it is very much like a pointer; it needs to point to something:

```
string_view bad()
{
    string s = "Once upon a time";
    return {&s[5],4}; // bad: returning a pointer to a local
}
```

We are returning a pointer to characters of a `string` that will be destroyed before we can use them.

One significant restriction of `string_view` is that it is a read-only view of its characters. For example, you cannot use a `string_view` to pass characters to a function that modifies its argument to lowercase. For that, you might consider using a `gsl::span` or `gsl::string_span` (§13.3).

The behavior of out-of-range access to a `string_view` is unspecified. If you want guaranteed range checking, use `at()`, which throws `out_of_range` for attempted out-of-range access, use a `gsl::string_span` (§13.3), or “just be careful.”

9.4 Regular Expressions

Regular expressions are a powerful tool for text processing. They provide a way to simply and tersely describe patterns in text (e.g., a U.S. postal code such as **TX 77845**, or an ISO-style date, such as **2009-06-07**) and to efficiently find such patterns. In `<regex>`, the standard library provides support for regular expressions in the form of the `std::regex` class and its supporting functions. To give a taste of the style of the `regex` library, let us define and print a pattern:

```
regex pat {R"(w{2}s*d{5}(-d{4})?)"}; // U.S. postal code pattern: XXdddd-dddd and variants
```

People who have used regular expressions in just about any language will find `w{2}s*d{5}(-d{4})?` familiar. It specifies a pattern starting with two letters `w{2}` optionally followed by some space `s*` followed by five digits `d{5}` and optionally followed by a dash and four digits `-d{4}`. If you are not familiar with regular expressions, this may be a good time to learn about them ([Stroustrup,2009], [Maddock,2009], [Friedl,1997]).

To express the pattern, I use a *raw string literal* starting with `R"` (and terminated by `")`. This allows backslashes and quotes to be used directly in the string. Raw strings are particularly suitable for regular expressions because they tend to contain a lot of backslashes. Had I used a conventional string, the pattern definition would have been:

```
regex pat {"\\w{2}\\s*d{5}(-d{4})?"}; // U.S. postal code pattern
```

In `<regex>`, the standard library provides support for regular expressions:

- `regex_match()`: Match a regular expression against a string (of known size) (§9.4.2).
- `regex_search()`: Search for a string that matches a regular expression in an (arbitrarily long) stream of data (§9.4.1).
- `regex_replace()`: Search for strings that match a regular expression in an (arbitrarily long) stream of data and replace them.
- `regex_iterator`: Iterate over matches and submatches (§9.4.3).
- `regex_token_iterator`: Iterate over non-matches.

9.4.1 Searching

The simplest way of using a pattern is to search for it in a stream:

```
int lineno = 0;
for (string line; getline(cin,line); ) { // read into line buffer
    ++lineno;
    smatch matches; // matched strings go here
    if (regex_search(line,matches,pat) // search for pat in line
        cout << lineno << " : " << matches[0] << '\n';
    }
}
```

The `regex_search(line,matches,pat)` searches the `line` for anything that matches the regular expression stored in `pat` and if it finds any matches, it stores them in `matches`. If no match was found, `regex_search(line,matches,pat)` returns `false`. The `matches` variable is of type `smatch`. The “s” stands for “sub” or “string,” and an `smatch` is a `vector` of submatches of type `string`. The first element, here `matches[0]`, is the complete match. The result of a `regex_search()` is a collection of matches, typically represented as an `smatch`:

```

void use()
{
    ifstream in("file.txt");    // input file
    if (!in)                    // check that the file was opened
        cerr << "no file\n";

    regex pat {R"(\w{2}\s*\d{5}(-\d{4})?)"}; // U.S. postal code pattern

    int lineno = 0;
    for (string line; getline(in,line); ) {
        ++lineno;
        smatch matches; // matched strings go here
        if (regex_search(line, matches, pat)) {
            cout << lineno << ": " << matches[0] << "\n"; // the complete match
            if (1 < matches.size() && matches[1].matched) // if there is a sub-pattern
                // and if it is matched
                cout << "\t: " << matches[1] << "\n"; // submatch
        }
    }
}

```

This function reads a file looking for U.S. postal codes, such as **TX77845** and **DC 20500-0001**. An **smatch** type is a container of regex results. Here, **matches[0]** is the whole pattern and **matches[1]** is the optional four-digit subpattern.

The newline character, **\n**, can be part of a pattern, so we can search for multiline patterns. Obviously, we shouldn't read one line at a time if we want to do that.

The regular expression syntax and semantics are designed so that regular expressions can be compiled into state machines for efficient execution [Cox,2007]. The **regex** type performs this compilation at run time.

9.4.2 Regular Expression Notation

The **regex** library can recognize several variants of the notation for regular expressions. Here, I use the default notation, a variant of the ECMA standard used for ECMAScript (more commonly known as JavaScript).

The syntax of regular expressions is based on characters with special meaning:

Regular Expression Special Characters			
.	Any single character (a “wildcard”)	\	Next character has a special meaning
[Begin character class	*	Zero or more (suffix operation)
]	End character class	+	One or more (suffix operation)
{	Begin count	?	Optional (zero or one) (suffix operation)
}	End count		Alternative (or)
(Begin grouping	^	Start of line; negation
)	End grouping	\$	End of line

For example, we can specify a line starting with zero or more **As** followed by one or more **Bs**

followed by an optional **C** like this:

```
^A*B+C?$
```

Examples that match:

```
AAAAAAAAAAAAABBBBBBBBBBC  
BC  
B
```

Examples that do not match:

```
AAAAA           // no B  
AAAABC          // initial space  
AABBCC          // too many Cs
```

A part of a pattern is considered a subpattern (which can be extracted separately from an **smatch**) if it is enclosed in parentheses. For example:

```
\d+~\d+         // no subpatterns  
\d+(-\d+)       // one subpattern  
(\d+)(-\d+)     // two subpatterns
```

A pattern can be optional or repeated (the default is exactly once) by adding a suffix:

Repetition	
{ n }	Exactly n times
{ n, }	n or more times
{n,m}	At least n and at most m times
*	Zero or more, that is, {0,}
+	One or more, that is, {1,}
?	Optional (zero or one), that is {0,1}

For example:

```
A{3}B{2,4}C*
```

Examples that match:

```
AAABBC  
AAABBB
```

Examples that do not match:

```
AABBC           // too few As  
AAABC           // too few Bs  
AAABBBBBCCC    // too many Bs
```

A suffix **?** after any of the repetition notations (**?**, *****, **+**, and **{ }**) makes the pattern matcher “lazy” or “non-greedy.” That is, when looking for a pattern, it will look for the shortest match rather than the longest. By default, the pattern matcher always looks for the longest match; this is known as the *Max Munch rule*. Consider:

```
ababab
```

The pattern `(ab)+` matches all of `ababab`. However, `(ab)+?` matches only the first `ab`.
The most common character classifications have names:

Character Classes	
<code>alnum</code>	Any alphanumeric character
<code>alpha</code>	Any alphabetic character
<code>blank</code>	Any whitespace character that is not a line separator
<code>cntrl</code>	Any control character
<code>d</code>	Any decimal digit
<code>digit</code>	Any decimal digit
<code>graph</code>	Any graphical character
<code>lower</code>	Any lowercase character
<code>print</code>	Any printable character
<code>punct</code>	Any punctuation character
<code>s</code>	Any whitespace character
<code>space</code>	Any whitespace character
<code>upper</code>	Any uppercase character
<code>w</code>	Any word character (alphanumeric characters plus the underscore)
<code>xdigit</code>	Any hexadecimal digit character

In a regular expression, a character class name must be bracketed by `[:]`. For example, `[digit:]` matches a decimal digit. Furthermore, they must be used within a `[]` pair defining a character class.

Several character classes are supported by shorthand notation:

Character Class Abbreviations		
<code>\d</code>	A decimal digit	<code>[[:digit:]]</code>
<code>\s</code>	A space (space, tab, etc.)	<code>[[:space:]]</code>
<code>\w</code>	A letter (a-z) or digit (0-9) or underscore (<code>_</code>)	<code>[[:alnum:]]</code>
<code>\D</code>	Not <code>\d</code>	<code>[^[:digit:]]</code>
<code>\S</code>	Not <code>\s</code>	<code>[^[:space:]]</code>
<code>\W</code>	Not <code>\w</code>	<code>[^[:alnum:]]</code>

In addition, languages supporting regular expressions often provide:

Nonstandard (but Common) Character Class Abbreviations		
<code>\l</code>	A lowercase character	<code>[[:lower:]]</code>
<code>\u</code>	An uppercase character	<code>[[:upper:]]</code>
<code>\L</code>	Not <code>\l</code>	<code>[^[:lower:]]</code>
<code>\U</code>	Not <code>\u</code>	<code>[^[:upper:]]</code>

For full portability, use the character class names rather than these abbreviations.

As an example, consider writing a pattern that describes C++ identifiers: an underscore or a letter followed by a possibly empty sequence of letters, digits, or underscores. To illustrate the subtleties involved, I include a few false attempts:

```

[:alpha:][:alnum:]*           // wrong: characters from the set ":alpha" followed by ...
[[:alpha:]][[:alnum:]]*      // wrong: doesn't accept underscore ('_' is not alpha)
([[:alpha:]]|_|[[:alnum:]])* // wrong: underscore is not part of alnum either

([[:alpha:]]|_|[[:alnum:]]|_)* // OK, but clumsy
[[:alpha:]][[:alnum:]]*      // OK: include the underscore in the character classes
[_[[:alpha:]][_[[:alnum:]]]* // also OK
[_[[:alpha:]]w]*           // w is equivalent to [_[[:alnum:]]]

```

Finally, here is a function that uses the simplest version of `regex_match()` (§9.4.1) to test whether a string is an identifier:

```

bool is_identifier(const string& s)
{
    regex pat {"[_[[:alpha:]]\\w*"}; // underscore or letter
                                   // followed by zero or more underscores, letters, or digits
    return regex_match(s,pat);
}

```

Note the doubling of the backslash to include a backslash in an ordinary string literal. Use raw string literals to alleviate problems with special characters. For example:

```

bool is_identifier(const string& s)
{
    regex pat {R"([_[[:alpha:]]w*)" };
    return regex_match(s,pat);
}

```

Here are some examples of patterns:

```

Ax*           // A, Ax, Axxxx
Ax+          // Ax, Axxx   Not A
\d-?\d       // 1-2, 12    Not 1--2
\w{2}-\d{4,5} // Ab-1234, XX-54321, 22-5432   Digits are in \w
(d*)?(d+)    // 12:3, 1:23, 123, :123   Not 123:
(bs|BS)      // bs, BS     Not bS
[aeiouy]     // a, o, u     An English vowel, not x
[^\aeiouy]   // x, k       Not an English vowel, not e
[a^eiouy]    // a, ^, o, u  An English vowel or ^

```

A **group** (a subpattern) potentially to be represented by a **sub_match** is delimited by parentheses. If you need parentheses that should not define a subpattern, use `(?:` rather than plain `(`. For example:

```

(\s|:|,)*(d*) // optional spaces, colons, and/or commas followed by an optional number

```

Assuming that we were not interested in the characters before the number (presumably separators), we could write:

```

(?:\s|:|,)*(d*) // optional spaces, colons, and/or commas followed by an optional number

```

This would save the regular expression engine from having to store the first characters: the `(?:` variant has only one subpattern.

Regular Expression Grouping Examples	
<code>ld*s\w+</code>	No groups (subpatterns)
<code>(ld*)\s(\w+)</code>	Two groups
<code>(ld*)(\s(\w+))+</code>	Two groups (groups do not nest)
<code>(\s*\w*)+</code>	One group; one or more subpatterns; only the last subpattern is saved as a sub_match
<code><(.*?)>(.*?)</1></code>	Three groups; the <code>\1</code> means “same as group 1”

That last pattern is useful for parsing XML. It finds tag/end-of-tag markers. Note that I used a non-greedy match (a *lazy match*), `.*?`, for the subpattern between the tag and the end tag. Had I used plain `.*`, this input would have caused a problem:

Always look on the bright side of life.

A *greedy match* for the first subpattern would match the first `<` with the last `>`. That would be correct behavior, but unlikely what the programmer wanted.

For a more exhaustive presentation of regular expressions, see [Friedl,1997].

9.4.3 Iterators

We can define a **regex_iterator** for iterating over a sequence of characters finding matches for a pattern. For example, we can use a **sregex_iterator** (a **regex_iterator<string>**) to output all whitespace-separated words in a **string**:

```
void test()
{
    string input = "aa as; asd ++e^asdf asdfg";
    regex pat {R"(\s+(\w+))"};
    for (sregex_iterator p(input.begin(),input.end(),pat); p!=sregex_iterator{}; ++p)
        cout << (*p)[1] << '\n';
}
```

This outputs:

```
as
asd
asdfg
```

We missed the first word, **aa**, because it has no preceding whitespace. If we simplify the pattern to **R"((\w+))"**, we get

```
aa
as
asd
e
asdf
asdfg
```

A **regex_iterator** is a bidirectional iterator, so we cannot directly iterate over an **istream** (which offers only an input iterator). Also, we cannot write through a **regex_iterator**, and the default **regex_iterator** (**regex_iterator{}**) is the only possible end-of-sequence.

9.5 Advice

- [1] Use `std::string` to own character sequences; §9.2; [CG: SL.str.1].
- [2] Prefer `string` operations to C-style string functions; §9.1.
- [3] Use `string` to declare variables and members rather than as a base class; §9.2.
- [4] Return `strings` by value (rely on move semantics); §9.2, §9.2.1.
- [5] Directly or indirectly, use `substr()` to read substrings and `replace()` to write substrings; §9.2.
- [6] A `string` can grow and shrink, as needed; §9.2.
- [7] Use `at()` rather than iterators or `[]` when you want range checking; §9.2.
- [8] Use iterators and `[]` rather than `at()` when you want to optimize speed; §9.2.
- [9] `string` input doesn't overflow; §9.2, §10.3.
- [10] Use `c_str()` to produce a C-style string representation of a `string` (only) when you have to; §9.2.
- [11] Use a `stringstream` or a generic value extraction function (such as `to<X>`) for numeric conversion of strings; §10.8.
- [12] A `basic_string` can be used to make strings of characters on any type; §9.2.1.
- [13] Use the `s` suffix for string literals meant to be standard-library `strings`; §9.3 [CG: SL.str.12].
- [14] Use `string_view` as an argument of functions that needs to read character sequences stored in various ways; §9.3 [CG: SL.str.2].
- [15] Use `gsl::string_span` as an argument of functions that needs to write character sequences stored in various ways; §9.3. [CG: SL.str.2] [CG: SL.str.11].
- [16] Think of a `string_view` as a kind of pointer with a size attached; it does not own its characters; §9.3.
- [17] Use the `sv` suffix for string literals meant to be standard-library `string_views`; §9.3.
- [18] Use `regex` for most conventional uses of regular expressions; §9.4.
- [19] Prefer raw string literals for expressing all but the simplest patterns; §9.4.
- [20] Use `regex_match()` to match a complete input; §9.4, §9.4.2.
- [21] Use `regex_search()` to search for a pattern in an input stream; §9.4.1.
- [22] The regular expression notation can be adjusted to match various standards; §9.4.2.
- [23] The default regular expression notation is that of ECMAScript; §9.4.2.
- [24] Be restrained; regular expressions can easily become a write-only language; §9.4.2.
- [25] Note that `\i` allows you to express a subpattern in terms of a previous subpattern; §9.4.2.
- [26] Use `?` to make patterns “lazy”; §9.4.2.
- [27] Use `regex_iterators` for iterating over a stream looking for a pattern; §9.4.3.

10

Input and Output

What you see is all you get.
– Brian W. Kernighan

- Introduction
- Output
- Input
- I/O State
- I/O of User-Defined Types
- Formatting
- File Streams
- String Streams
- C-style I/O
- File System
- Advice

10.1 Introduction

The I/O stream library provides formatted and unformatted buffered I/O of text and numeric values. An **ostream** converts typed objects to a stream of characters (bytes):

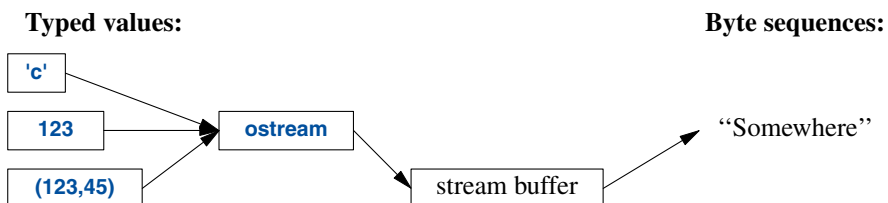

An **istream** converts a stream of characters (bytes) to typed objects:

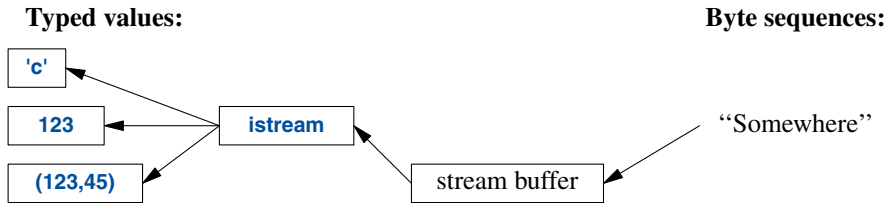

The operations on **istreams** and **ostreams** are described in §10.2 and §10.3. The operations are type-safe, type-sensitive, and extensible to handle user-defined types (§10.5).

Other forms of user interaction, such as graphical I/O, are handled through libraries that are not part of the ISO standard and therefore not described here.

These streams can be used for binary I/O, be used for a variety of character types, be locale specific, and use advanced buffering strategies, but these topics are beyond the scope of this book.

The streams can be used for input into and output from **std::strings** (§10.3), for formatting into **string** buffers (§10.8), and for file I/O (§10.10).

The I/O stream classes all have destructors that free all resources owned (such as buffers and file handles). That is, they are examples of "Resource Acquisition Is Initialization" (RAII; §5.3).

10.2 Output

In **<ostream>**, the I/O stream library defines output for every built-in type. Further, it is easy to define output of a user-defined type (§10.5). The operator **<<** ("put to") is used as an output operator on objects of type **ostream**; **cout** is the standard output stream and **cerr** is the standard stream for reporting errors. By default, values written to **cout** are converted to a sequence of characters. For example, to output the decimal number **10**, we can write:

```
void f()
{
    cout << 10;
}
```

This places the character **1** followed by the character **0** on the standard output stream.

Equivalently, we could write:

```
void g()
{
    int x {10};
    cout << x;
}
```

Output of different types can be combined in the obvious way:

```
void h(int i)
{
    cout << "the value of i is ";
    cout << i;
    cout << '\n';
}
```

For `h(10)`, the output will be:

```
the value of i is 10
```

People soon tire of repeating the name of the output stream when outputting several related items. Fortunately, the result of an output expression can itself be used for further output. For example:

```
void h2(int i)
{
    cout << "the value of i is " << i << '\n';
}
```

This `h2()` produces the same output as `h()`.

A character constant is a character enclosed in single quotes. Note that a character is output as a character rather than as a numerical value. For example:

```
void k()
{
    int b = 'b';    // note: char implicitly converted to int
    char c = 'c';
    cout << 'a' << b << c;
}
```

The integer value of the character `'b'` is **98** (in the ASCII encoding used on the C++ implementation that I used), so this will output **a98c**.

10.3 Input

In `<istream>`, the standard library offers `istream`s for input. Like `ostream`s, `istream`s deal with character string representations of built-in types and can easily be extended to cope with user-defined types.

The operator `>>` (“get from”) is used as an input operator; `cin` is the standard input stream. The type of the right-hand operand of `>>` determines what input is accepted and what is the target of the input operation. For example:

```
void f()
{
    int i;
    cin >> i;    // read an integer into i

    double d;
    cin >> d;    // read a double-precision floating-point number into d
}
```

This reads a number, such as **1234**, from the standard input into the integer variable **i** and a floating-point number, such as **12.34e5**, into the double-precision floating-point variable **d**.

Like output operations, input operations can be chained, so I could equivalently have written:

```
void f()
{
    int i;
    double d;
    cin >> i >> d;    // read into i and d
}
```

In both cases, the read of the integer is terminated by any character that is not a digit. By default, **>>** skips initial whitespace, so a suitable complete input sequence would be

```
1234
12.34e5
```

Often, we want to read a sequence of characters. A convenient way of doing that is to read into a **string**. For example:

```
void hello()
{
    cout << "Please enter your name\n";
    string str;
    cin >> str;
    cout << "Hello, " << str << "!\n";
}
```

If you type in **Eric** the response is:

```
Hello, Eric!
```

By default, a whitespace character, such as a space or a newline, terminates the read, so if you enter **Eric Bloodaxe** pretending to be the ill-fated king of York, the response is still:

```
Hello, Eric!
```

You can read a whole line using the **getline()** function. For example:

```
void hello_line()
{
    cout << "Please enter your name\n";
    string str;
    getline(cin, str);
    cout << "Hello, " << str << "!\n";
}
```

With this program, the input **Eric Bloodaxe** yields the desired output:

```
Hello, Eric Bloodaxe!
```

The newline that terminated the line is discarded, so **cin** is ready for the next input line.

Using the formatted I/O operations is usually less error-prone, more efficient, and less code than manipulating characters one by one. In particular, **istreams** take care of memory management and range checking. We can do formatting to and from memory using **stringstreams** (§10.8).

The standard strings have the nice property of expanding to hold what you put in them; you don't have to pre-calculate a maximum size. So, if you enter a couple of megabytes of semicolons, the program will echo pages of semicolons back at you.

10.4 I/O State

An `istream` has a state that we can examine to determine whether an operation succeeded. The most common use is to read a sequence of values:

```
vector<int> read_ints(istream& is)
{
    vector<int> res;
    for (int i; is>>i; )
        res.push_back(i);
    return res;
}
```

This reads from `is` until something that is not an integer is encountered. That something will typically be the end of input. What is happening here is that the operation `is>>i` returns a reference to `is`, and testing an `istream` yields `true` if the stream is ready for another operation.

In general, the I/O state holds all the information needed to read or write, such as formatting information (§10.6), error state (e.g., has end-of-input been reached?), and what kind of buffering is used. In particular, a user can set the state to reflect that an error has occurred (§10.5) and clear the state if an error wasn't serious. For example, we could imagine a version of `read_ints()` that accepted a terminating string:

```
vector<int> read_ints(istream& is, const string& terminator)
{
    vector<int> res;
    for (int i; is >> i; )
        res.push_back(i);

    if (is.eof())           // fine: end of file
        return res;

    if (is.fail()) {       // we failed to read an int; was it the terminator?
        is.clear();       // reset the state to good()
        is.unget();       // put the non-digit back into the stream
        string s;
        if (cin>>s && s==terminator)
            return res;
        cin.setstate(ios_base::failbit); // add fail() to cin's state
    }

    return res;
}

auto v = read_ints(cin, "stop");
```

10.5 I/O of User-Defined Types

In addition to the I/O of built-in types and standard **strings**, the **iostream** library allows programmers to define I/O for their own types. For example, consider a simple type **Entry** that we might use to represent entries in a telephone book:

```
struct Entry {
    string name;
    int number;
};
```

We can define a simple output operator to write an **Entry** using a `{"name",number}` format similar to the one we use for initialization in code:

```
ostream& operator<<(ostream& os, const Entry& e)
{
    return os << "{" << e.name << "\", " << e.number << "}";
}
```

A user-defined output operator takes its output stream (by reference) as its first argument and returns it as its result.

The corresponding input operator is more complicated because it has to check for correct formatting and deal with errors:

```
istream& operator>>(istream& is, Entry& e)
    // read { "name", number } pair. Note: formatted with { " ", and }
{
    char c, c2;
    if (is>>c && c=='{' && is>>c2 && c2=="") { // start with a { "
        string name; // the default value of a string is the empty string: ""
        while (is.get(c) && c!="") // anything before a " is part of the name
            name+=c;

        if (is>>c && c==',') {
            int number = 0;
            if (is>>number>>c && c=="}") { // read the number and a }
                e = {name,number}; // assign to the entry
                return is;
            }
        }
    }
    is.setstate(ios_base::failbit); // register the failure in the stream
    return is;
}
```

An input operation returns a reference to its **istream** that can be used to test if the operation succeeded. For example, when used as a condition, `is>>c` means “Did we succeed at reading a **char** from **is** into **c**?”

The `is>>c` skips whitespace by default, but `is.get(c)` does not, so this **Entry**-input operator ignores (skips) whitespace outside the name string, but not within it. For example:

```
{ "John Marwood Cleese", 123456    }
{"Michael Edward Palin", 987654}
```

We can read such a pair of values from input into an **Entry** like this:

```
for (Entry ee; cin>>ee; ) // read from cin into ee
    cout << ee << '\n'; // write ee to cout
```

The output is:

```
{"John Marwood Cleese", 123456}
{"Michael Edward Palin", 987654}
```

See §9.4 for a more systematic technique for recognizing patterns in streams of characters (regular expression matching).

10.6 Formatting

The **ostream** library provides a large set of operations for controlling the format of input and output. The simplest formatting controls are called *manipulators* and are found in `<ios>`, `<istream>`, `<ostream>`, and `<iomanip>` (for manipulators that take arguments). For example, we can output integers as decimal (the default), octal, or hexadecimal numbers:

```
cout << 1234 << ',' << hex << 1234 << ',' << oct << 1234 << '\n'; // print 1234,4d2,2322
```

We can explicitly set the output format for floating-point numbers:

```
constexpr double d = 123.456;

cout << d << "; " // use the default format for d
    << scientific << d << "; " // use 1.123e2 style format for d
    << hexfloat << d << "; " // use hexadecimal notation for d
    << fixed << d << "; " // use 123.456 style format for d
    << defaultfloat << d << '\n'; // use the default format for d
```

This produces:

```
123.456; 1.234560e+002; 0x1.edd2f2p+6; 123.456000; 123.456
```

Precision is an integer that determines the number of digits used to display a floating-point number:

- The *general* format (**defaultfloat**) lets the implementation choose a format that presents a value in the style that best preserves the value in the space available. The precision specifies the maximum number of digits.
- The *scientific* format (**scientific**) presents a value with one digit before a decimal point and an exponent. The precision specifies the maximum number of digits after the decimal point.
- The *fixed* format (**fixed**) presents a value as an integer part followed by a decimal point and a fractional part. The precision specifies the maximum number of digits after the decimal point.

Floating-point values are rounded rather than just truncated, and **precision()** doesn't affect integer output. For example:

```
cout.precision(8);
cout << 1234.56789 << ' ' << 1234.56789 << ' ' << 123456 << '\n';

cout.precision(4);
cout << 1234.56789 << ' ' << 1234.56789 << ' ' << 123456 << '\n';
cout << 1234.56789 << '\n';
```

This produces:

```
1234.5679 1234.5679 123456
1235 1235 123456
1235
```

These floating-point manipulators are “sticky”; that is, their effects persist for subsequent floating-point operations.

10.7 File Streams

In `<fstream>`, the standard library provides streams to and from a file:

- `ifstream`s for reading from a file
- `ofstream`s for writing to a file
- `fstream`s for reading from and writing to a file

For example:

```
ofstream ofs {"target"};           // "o" for "output"
if (!ofs)
    error("couldn't open 'target' for writing");
```

Testing that a file stream has been properly opened is usually done by checking its state.

```
ifstream ifs {"source"};         // "i" for "input"
if (!ifs)
    error("couldn't open 'source' for reading");
```

Assuming that the tests succeeded, `ofs` can be used as an ordinary `ostream` (just like `cout`) and `ifs` can be used as an ordinary `istream` (just like `cin`).

File positioning and more detailed control of the way a file is opened is possible, but beyond the scope of this book.

For the composition of file names and file system manipulation, see §10.10.

10.8 String Streams

In `<stringstream>`, the standard library provides streams to and from a `string`:

- `istringstreams` for reading from a `string`
- `ostringstream`s for writing to a `string`
- `stringstream`s for reading from and writing to a `string`.

For example:

```

void test()
{
    ostream oss;

    oss << "temperature," << scientific << 123.4567890 << " ";
    cout << oss.str() << "\n";
}

```

The result from an `ostream` can be read using `str()`. One common use of an `ostream` is to format before giving the resulting string to a GUI. Similarly, a string received from a GUI can be read using formatted input operations (§10.3) by putting it into an `istream`.

A `stringstream` can be used for both reading and writing. For example, we can define an operation that can convert any type with a `string` representation into another that can also be represented as a `string`:

```

template<typename Target =string, typename Source =string>
Target to(Source arg)          // convert Source to Target
{
    stringstream interpreter;
    Target result;

    if (!(interpreter << arg)           // write arg into stream
        || !(interpreter >> result)    // read result from stream
        || !(interpreter >> std::ws).eof()) // stuff left in stream?
        throw runtime_error{"to<>() failed"};

    return result;
}

```

A function template argument needs to be explicitly mentioned only if it cannot be deduced or if there is no default (§7.2.4), so we can write:

```

auto x1 = to<string,double>(1.2); // very explicit (and verbose)
auto x2 = to<string>(1.2);        // Source is deduced to double
auto x3 = to<>(1.2);             // Target is defaulted to string; Source is deduced to double
auto x4 = to(1.2);              // the <> is redundant;
                                // Target is defaulted to string; Source is deduced to double

```

If all function template arguments are defaulted, the `<>` can be left out.

I consider this a good example of the generality and ease of use that can be achieved by a combination of language features and standard-library facilities.

10.9 C-style I/O

The C++ standard library also supports the C standard-library I/O, including `printf()` and `scanf()`. Many uses of this library are unsafe from a type and security point-of-view, so I don't recommend its use. In particular, it can be difficult to use for safe and convenient input. It does not support user-defined types. If you *don't* use C-style I/O and care about I/O performance, call

```
ios_base::sync_with_stdio(false);    // avoid significant overhead
```

Without that call, `iostreams` can be significantly slowed down to be compatible with the C-style I/O.

10.10 File System

Most systems have a notion of a *file system* providing access to permanent information stored as *files*. Unfortunately, the properties of file systems and the ways of manipulating them vary greatly. To deal with that, the file system library in `<filesystem>` offers a uniform interface to most facilities of most file systems. Using `<filesystem>`, we can portably

- express file system paths and navigate through a file system
- examine file types and the permissions associated with them

The `filesystem` library can handle unicode, but explaining how is beyond the scope of this book. I recommend the `cppreference` [Cppreference] and the Boost `filesystem` documentation [Boost] for detailed information.

Consider an example:

```
path f = "dir/hypothetical.cpp";    // naming a file

assert(exists(f));                 // f must exist

if (is_regular_file(f))            // is f an ordinary file?
    cout << f << " is a file; its size is " << file_size(f) << '\n';
```

Note that a program manipulating a file system is usually running on a computer together with other programs. Thus, the contents of a file system can change between two commands. For example, even though we first of all carefully asserted that `f` existed, that may no longer be true when on the next line, we ask if `f` is a regular file.

A `path` is quite a complicated class, capable of handling the native character sets and conventions of many operating systems. In particular, it can handle file names from command lines as presented by `main()`; for example:

```
int main(int argc, char* argv[])
{
    if (argc < 2) {
        cerr << "arguments expected\n";
        return 1;
    }

    path p {argv[1]};    // create a path from the command line

    cout << p << " " << exists(p) << '\n';    // note: a path can be printed like a string
    // ...
}
```

A `path` is not checked for validity until it is used. Even then, its validity depends on the conventions of the system on which the program runs.

Naturally, a `path` can be used to open a file

```
void use(path p)
{
    ofstream f {p};
    if (!f) error("bad file name: ", p);
    f << "Hello, file!";
}
```

In addition to `path`, `<filesystem>` offers types for traversing directories and inquiring about the properties of the files found:

File System Types (partial)	
<code>path</code>	A directory path
<code>filesystem_error</code>	A file system exception
<code>directory_entry</code>	A directory entry
<code>directory_iterator</code>	For iterating over a directory
<code>recursive_directory_iterator</code>	For iterating over a directory and its subdirectories

Consider a simple, but not completely unrealistic, example:

```
void print_directory(path p)
try
{
    if (is_directory(p)) {
        cout << p << "\n";
        for (const directory_entry& x : directory_iterator(p))
            cout << "  " << x.path() << "\n";
    }
}
catch (const filesystem_error& ex) {
    cerr << ex.what() << "\n";
}
```

A string can be implicitly converted to a `path` so we can exercise `print_directory` like this:

```
void use()
{
    print_directory("."); // current directory
    print_directory(".."); // parent directory
    print_directory("/"); // Unix root directory
    print_directory("c:"); // Windows volume C

    for (string s; cin>>s; )
        print_directory(s);
}
```

Had I wanted to list subdirectories also, I would have said `recursive_directory_iterator{p}`. Had I wanted to print entries in lexicographical order, I would have copied the `paths` into a `vector` and sorted that before printing.

Class `path` offers many common and useful operations:

Path Operations (partial) p and p2 are paths	
value_type	Character type used by the native encoding of the filesystem: char on POSIX, wchar_t on Windows
string_type	std::basic_string<value_type>
const_iterator	A const BidirectionalIterator with a value_type of path
iterator	Alias for const_iterator
p=p2	Assign p2 to p
p/=p2	p and p2 concatenated using the file-name separator (by default /)
p+=p2	p and p2 concatenated (no separator)
p.native()	The native format of p
p.string()	p in the native format of p as a string
p.generic_string()	p in the generic format as a string
p.filename()	The filename part of p
p.stem()	The stem part of p
p.extension()	The file extension part of p
p.begin()	The beginning of p 's element sequence
p.end()	The end of p 's element sequence
p==p2, p!=p2	Equality and inequality for p and p2
p<p2, p<=p2, p>p2, p>=p2	Lexicographical comparisons
is>>p, os<<p	Stream I/O to/from p
u8path(s)	A path from a UTF-8 encoded source s

For example:

```
void test(path p)
{
    if (is_directory(p)) {
        cout << p << "\n";
        for (const directory_entry& x : directory_iterator(p)) {
            const path& f = x; // refer to the path part of a directory entry
            if (f.extension() == ".exe")
                cout << f.stem() << " is a Windows executable\n";
            else {
                string n = f.extension().string();
                if (n == ".cpp" || n == ".C" || n == ".cxx")
                    cout << f.stem() << " is a C++ source file\n";
            }
        }
    }
}
```

We use a `path` as a string (e.g., `f.extension()`) and we can extract strings of various types from a `path` (e.g., `f.extension().string()`).

Note that naming conventions, natural languages, and string encodings are rich in complexity. The filesystem-library abstractions offer portability and great simplification.

File System Operations (partial)	
p, p1, and p2 are paths; e is an error_code; b is a bool indicating success or failure	
exists(p)	Does p refer to an existing file system object?
copy(p1,p2)	Copy files or directories from p1 to p2 ; report errors as exceptions
copy(p1,p2,e)	Copy files or directories; report errors as error codes
b=copy_file(p1,p2)	Copy file contents from p1 to p2 ; report errors as exceptions
b=create_directory(p)	Create new directory named p ; all intermediate directories on p must exist
b=create_directories(p)	Create new directory named p ; create all intermediate directories on p
p=current_path()	p is the current working directory
current_path(p)	Make p the current working directory
s=file_size(p)	s is the number of bytes in p
b=remove(p)	Remove p if it is a file or an empty directory

Many operations have overloads that take extra arguments, such as operating systems permissions. The handling of such is far beyond the scope of this book, so look them up if you need them.

Like `copy()`, all operations come in two versions:

- The basic version as listed in the table, e.g., `exists(p)`. The function will throw `filesystem_error` if the operation failed.
- A version with an extra `error_code` argument, e.g., `exists(p,e)`. Check `e` to see if the operations succeeded.

We use the error codes when operations are expected to fail frequently in normal use and the throwing operations when an error is considered exceptional.

Often, using an inquiry function is the simplest and most straightforward approach to examining the properties of a file. The `<filesystem>` library knows about a few common kinds of files and classifies the rest as “other”:

File types	
f Is a path or a file_status	
is_block_file(f)	Is f a block device?
is_character_file(f)	Is f a character device?
is_directory(f)	Is f a directory?
is_empty(f)	Is f an empty file or directory?
is_fifo(f)	Is f a named pipe?
is_other(f)	Is f some other kind of file?
is_regular_file(f)	Is f a regular (ordinary) file?
is_socket(f)	Is f a named IPC socket?
is_symlink(f)	Is f a symbolic link?
status_known(f)	Is f 's file status known?

10.11 Advice

- [1] `iostreams` are type-safe, type-sensitive, and extensible; §10.1.
- [2] Use character-level input only when you have to; §10.3; [CG: SL.io.1].
- [3] When reading, always consider ill-formed input; §10.3; [CG: SL.io.2].
- [4] Avoid `endl` (if you don't know what `endl` is, you haven't missed anything); [CG: SL.io.50].
- [5] Define `<<` and `>>` for user-defined types with values that have meaningful textual representations; §10.1, §10.2, §10.3.
- [6] Use `cout` for normal output and `cerr` for errors; §10.1.
- [7] There are `iostreams` for ordinary characters and wide characters, and you can define an `iostream` for any kind of character; §10.1.
- [8] Binary I/O is supported; §10.1.
- [9] There are standard `iostreams` for standard I/O streams, files, and `strings`; §10.2, §10.3, §10.7, §10.8.
- [10] Chain `<<` operations for a terser notation; §10.2.
- [11] Chain `>>` operations for a terser notation; §10.3.
- [12] Input into `strings` does not overflow; §10.3.
- [13] By default `>>` skips initial whitespace; §10.3.
- [14] Use the stream state `fail` to handle potentially recoverable I/O errors; §10.4.
- [15] You can define `<<` and `>>` operators for your own types; §10.5.
- [16] You don't need to modify `istream` or `ostream` to add new `<<` and `>>` operators; §10.5.
- [17] Use manipulators to control formatting; §10.6.
- [18] `precision()` specifications apply to all following floating-point output operations; §10.6.
- [19] Floating-point format specifications (e.g., `scientific`) apply to all following floating-point output operations; §10.6.
- [20] `#include <ios>` when using standard manipulators; §10.6.
- [21] `#include <iomanip>` when using standard manipulators taking arguments; §10.6.
- [22] Don't try to copy a file stream.
- [23] Remember to check that a file stream is attached to a file before using it; §10.7.
- [24] Use `stringstreams` for in-memory formatting; §10.8.
- [25] You can define conversions between any two types that both have string representation; §10.8.
- [26] C-style I/O is not type-safe; §10.9.
- [27] Unless you use `printf`-family functions call `ios_base::sync_with_stdio(false)`; §10.9; [CG: SL.io.10].
- [28] Prefer `<filesystem>` to direct use of a specific operating system interfaces; §10.10.

Containers

*It was new.
It was singular.
It was simple.
It must succeed!
– H. Nelson*

- Introduction
- **vector**
 - Elements; Range Checking
- **list**
- **map**
- **unordered_map**
- Container Overview
- Advice

11.1 Introduction

Most computing involves creating collections of values and then manipulating such collections. Reading characters into a **string** and printing out the **string** is a simple example. A class with the main purpose of holding objects is commonly called a *container*. Providing suitable containers for a given task and supporting them with useful fundamental operations are important steps in the construction of any program.

To illustrate the standard-library containers, consider a simple program for keeping names and telephone numbers. This is the kind of program for which different approaches appear “simple and obvious” to people of different backgrounds. The **Entry** class from §10.5 can be used to hold a simple phone book entry. Here, we deliberately ignore many real-world complexities, such as the fact that many phone numbers do not have a simple representation as a 32-bit **int**.

11.2 vector

The most useful standard-library container is **vector**. A **vector** is a sequence of elements of a given type. The elements are stored contiguously in memory. A typical implementation of **vector** (§4.2.2, §5.2) will consist of a handle holding pointers to the first element, one-past-the-last element, and one-past-the-last allocated space (§12.1) (or the equivalent information represented as a pointer plus offsets):

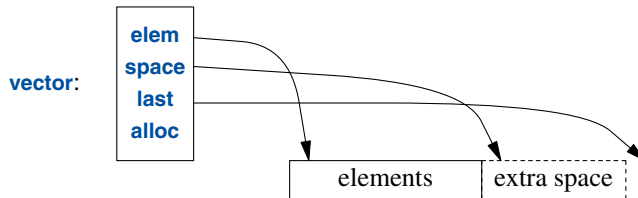

In addition, it holds an allocator (here, **alloc**), from which the **vector** can acquire memory for its elements. The default allocator uses **new** and **delete** to acquire and release memory (§13.6).

We can initialize a **vector** with a set of values of its element type:

```
vector<Entry> phone_book = {
    {"David Hume",123456},
    {"Karl Popper",234567},
    {"Bertrand Arthur William Russell",345678}
};
```

Elements can be accessed through subscripting. So, assuming that we have defined **<<** for **Entry**, we can write:

```
void print_book(const vector<Entry>& book)
{
    for (int i = 0; i!=book.size(); ++i)
        cout << book[i] << '\n';
}
```

As usual, indexing starts at **0** so that **book[0]** holds the entry for **David Hume**. The **vector** member function **size()** gives the number of elements.

The elements of a **vector** constitute a range, so we can use a range-**for** loop (§1.7):

```
void print_book(const vector<Entry>& book)
{
    for (const auto& x : book)    // for "auto" see §1.4
        cout << x << '\n';
}
```

When we define a **vector**, we give it an initial size (initial number of elements):

```
vector<int> v1 = {1, 2, 3, 4};        // size is 4
vector<string> v2;                  // size is 0
vector<Shape*> v3(23);              // size is 23; initial element value: nullptr
vector<double> v4(32,9.9);         // size is 32; initial element value: 9.9
```

An explicit size is enclosed in ordinary parentheses, for example, (23), and by default, the elements are initialized to the element type's default value (e.g., `nullptr` for pointers and `0` for numbers). If you don't want the default value, you can specify one as a second argument (e.g., 9.9 for the 32 elements of `v4`).

The initial size can be changed. One of the most useful operations on a `vector` is `push_back()`, which adds a new element at the end of a `vector`, increasing its size by one. For example, assuming that we have defined `>>` for `Entry`, we can write:

```
void input()
{
    for (Entry e; cin>>e; )
        phone_book.push_back(e);
}
```

This reads `Entries` from the standard input into `phone_book` until either the end-of-input (e.g., the end of a file) is reached or the input operation encounters a format error.

The standard-library `vector` is implemented so that growing a `vector` by repeated `push_back()`s is efficient. To show how, consider an elaboration of the simple `Vector` from (Chapter 4 and Chapter 6) using the representation indicated in the diagram above:

```
template<typename T>
class Vector {
    T* elem;           // pointer to first element
    T* space;         // pointer to first unused (and uninitialized) slot
    T* last;          // pointer to last slot
public:
    // ...
    int size();       // number of elements (space-elem)
    int capacity();  // number of slots available for elements (last-elem)
    // ...
    void reserve(int newsz); // increase capacity() to newsz
    // ...
    void push_back(const T& t); // copy t into Vector
    void push_back(T&& t);     // move t into Vector
};
```

The standard-library `vector` has members `capacity()`, `reserve()`, and `push_back()`. The `reserve()` is used by users of `vector` and other `vector` members to make room for more elements. It may have to allocate new memory and when it does, it moves the elements to the new allocation.

Given `capacity()` and `reserve()`, implementing `push_back()` is trivial:

```
template<typename T>
void Vector<T>::push_back(const T& t)
{
    if (capacity()<size()+1) // make sure we have space for t
        reserve(size()==0?8:2*size()); // double the capacity
    new(space) T{t};        // initialize *space to t
    ++space;
}
```

Now allocation and relocation of elements happens only infrequently. I used to use `reserve()` to try to improve performance, but that turned out to be a waste of effort: the heuristic used by `vector` is on average better than my guesses, so now I only explicitly use `reserve()` to avoid reallocation of elements when I want to use pointers to elements.

A `vector` can be copied in assignments and initializations. For example:

```
vector<Entry> book2 = phone_book;
```

Copying and moving of `vectors` are implemented by constructors and assignment operators as described in §5.2. Assigning a `vector` involves copying its elements. Thus, after the initialization of `book2`, `book2` and `phone_book` hold separate copies of every `Entry` in the phone book. When a `vector` holds many elements, such innocent-looking assignments and initializations can be expensive. Where copying is undesirable, references or pointers (§1.7) or move operations (§5.2.2) should be used.

The standard-library `vector` is very flexible and efficient. Use it as your default container; that is, use it unless you have a solid reason to use some other container. If you avoid `vector` because of concerns about “efficiency,” measure. Our intuition is most fallible in matters of the performance of container uses.

11.2.1 Elements

Like all standard-library containers, `vector` is a container of elements of some type `T`, that is, a `vector<T>`. Just about any type qualifies as an element type: built-in numeric types (such as `char`, `int`, and `double`), user-defined types (such as `string`, `Entry`, `list<int>`, and `Matrix<double,2>`), and pointers (such as `const char*`, `Shape*`, and `double*`). When you insert a new element, its value is copied into the container. For example, when you put an integer with the value `7` into a container, the resulting element really has the value `7`. The element is not a reference or a pointer to some object containing `7`. This makes for nice, compact containers with fast access. For people who care about memory sizes and run-time performance this is critical.

If you have a class hierarchy (§4.5) that relies on `virtual` functions to get polymorphic behavior, do not store objects directly in a container. Instead store a pointer (or a smart pointer; §13.2.1). For example:

```
vector<Shape> vs;           // No, don't - there is no room for a Circle or a Smiley
vector<Shape*> vps;        // better, but see §4.5.3
vector<unique_ptr<Shape>> vups; // OK
```

11.2.2 Range Checking

The standard-library `vector` does not guarantee range checking. For example:

```
void silly(vector<Entry>& book)
{
    int i = book[book.size()].number;    // book.size() is out of range
    // ...
}
```

That initialization is likely to place some random value in `i` rather than giving an error. This is undesirable, and out-of-range errors are a common problem. Consequently, I often use a simple range-checking adaptation of `vector`:

```
template<typename T>
class Vec : public std::vector<T> {
public:
    using vector<T>::vector;           // use the constructors from vector (under the name Vec)

    T& operator[](int i)               // range check
        { return vector<T>::at(i); }

    const T& operator[](int i) const  // range check const objects; §4.2.1
        { return vector<T>::at(i); }
};
```

`Vec` inherits everything from `vector` except for the subscript operations that it redefines to do range checking. The `at()` operation is a `vector` subscript operation that throws an exception of type `out_of_range` if its argument is out of the `vector`'s range (§3.5.1).

For `Vec`, an out-of-range access will throw an exception that the user can catch. For example:

```
void checked(Vec<Entry>& book)
{
    try {
        book[book.size()] = {"Joe",999999}; // will throw an exception
        // ...
    }
    catch (out_of_range&) {
        cerr << "range error\n";
    }
}
```

The exception will be thrown, and then caught (§3.5.1). If the user doesn't catch an exception, the program will terminate in a well-defined manner rather than proceeding or failing in an undefined manner. One way to minimize surprises from uncaught exceptions is to use a `main()` with a `try`-block as its body. For example:

```
int main()
try {
    // your code
}
catch (out_of_range&) {
    cerr << "range error\n";
}
catch (...) {
    cerr << "unknown exception thrown\n";
}
```

This provides default exception handlers so that if we fail to catch some exception, an error message is printed on the standard error-diagnostic output stream `cerr` (§10.2).

Why doesn't the standard guarantee range checking? Many performance-critical applications use **vector** and checking all subscripting implies a cost on the order of 10%. Obviously, that cost can vary dramatically depending on hardware, optimizers, and an application's use of subscripting. However, experience shows that such overhead can lead people to prefer the far more unsafe built-in arrays. Even the mere fear of such overhead can lead to disuse. At least **vector** is easily range checked at debug time and we can build checked versions on top of the unchecked default. Some implementations save you the bother of defining **Vec** (or equivalent) by providing a range-checked version of **vector** (e.g., as a compiler option).

A range-**for** avoids range errors at no cost by accessing elements through iterators in the range [**begin():end()**). As long as their iterator arguments are valid, the standard-library algorithms do the same to ensure the absence of range errors.

If you can use **vector::at()** directly in your code, you don't need my **Vec** workaround. Furthermore, some standard libraries have range-checked **vector** implementations that offer more complete checking than **Vec**.

11.3 list

The standard library offers a doubly-linked list called **list**:

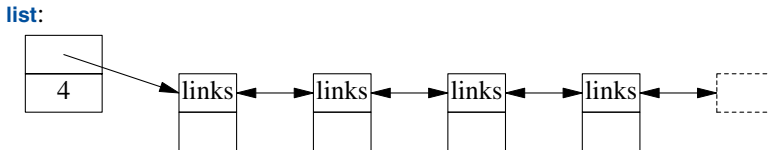

We use a **list** for sequences where we want to insert and delete elements without moving other elements. Insertion and deletion of phone book entries could be common, so a **list** could be appropriate for representing a simple phone book. For example:

```
list<Entry> phone_book = {
    {"David Hume",123456},
    {"Karl Popper",234567},
    {"Bertrand Arthur William Russell",345678}
};
```

When we use a linked list, we tend not to access elements using subscripting the way we commonly do for vectors. Instead, we might search the list looking for an element with a given value. To do this, we take advantage of the fact that a **list** is a sequence as described in Chapter 12:

```
int get_number(const string& s)
{
    for (const auto& x : phone_book)
        if (x.name==s)
            return x.number;
    return 0; // use 0 to represent "number not found"
}
```

The search for **s** starts at the beginning of the list and proceeds until **s** is found or the end of **phone_book** is reached.

Sometimes, we need to identify an element in a **list**. For example, we may want to delete an element or insert a new element before it. To do that we use an *iterator*: a **list** iterator identifies an element of a **list** and can be used to iterate through a **list** (hence its name). Every standard-library container provides the functions **begin()** and **end()**, which return an iterator to the first and to one-past-the-last element, respectively (Chapter 12). Using iterators explicitly, we can – less elegantly – write the **get_number()** function like this:

```
int get_number(const string& s)
{
    for (auto p = phone_book.begin(); p!=phone_book.end(); ++p)
        if (p->name==s)
            return p->number;
    return 0; // use 0 to represent "number not found"
}
```

In fact, this is roughly the way the terser and less error-prone range-**for** loop is implemented by the compiler. Given an iterator **p**, ***p** is the element to which it refers, **++p** advances **p** to refer to the next element, and when **p** refers to a class with a member **m**, then **p->m** is equivalent to **(*p).m**.

Adding elements to a **list** and removing elements from a **list** is easy:

```
void f(const Entry& ee, list<Entry>::iterator p, list<Entry>::iterator q)
{
    phone_book.insert(p,ee); // add ee before the element referred to by p
    phone_book.erase(q);    // remove the element referred to by q
}
```

For a **list**, **insert(p,elem)** inserts an element with a copy of the value **elem** before the element pointed to by **p**. Here, **p** may be an iterator pointing one-beyond-the-end of the **list**. Conversely, **erase(p)** removes the element pointed to by **p** and destroys it.

These **list** examples could be written identically using **vector** and (surprisingly, unless you understand machine architecture) perform better with a small **vector** than with a small **list**. When all we want is a sequence of elements, we have a choice between using a **vector** and a **list**. Unless you have a reason not to, use a **vector**. A **vector** performs better for traversal (e.g., **find()** and **count()**) and for sorting and searching (e.g., **sort()** and **equal_range()**; §12.6, §13.4.3).

The standard library also offers a singly-linked list called **forward_list**:

forward_list:

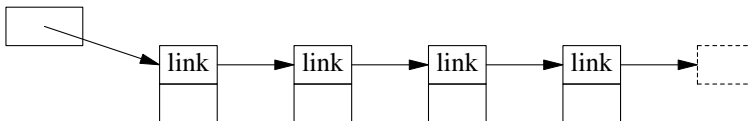

A **forward_list** differs from a **list** by only allowing forward iteration. The point of that is to save space. There is no need to keep a predecessor pointer in each link and the size of an empty **forward_list** is just one pointer. A **forward_list** doesn't even keep its number of elements. If you need the element count, count. If you can't afford to count, you probably shouldn't use a **forward_list**.

11.4 map

Writing code to look up a name in a list of *(name,number)* pairs is quite tedious. In addition, a linear search is inefficient for all but the shortest lists. The standard library offers a balanced binary search tree (usually, a red-black tree) called **map**:

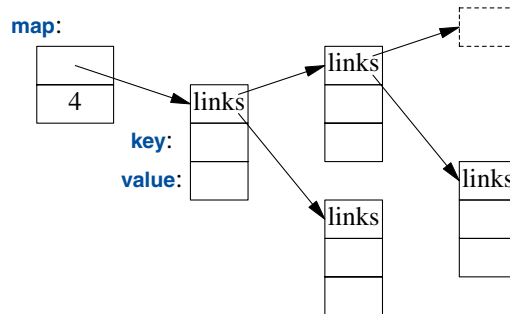

In other contexts, a **map** is known as an associative array or a dictionary. It is implemented as a balanced binary tree.

The standard-library **map** is a container of pairs of values optimized for lookup. We can use the same initializer as for **vector** and **list** (§11.2, §11.3):

```
map<string,int> phone_book {
    {"David Hume",123456},
    {"Karl Popper",234567},
    {"Bertrand Arthur William Russell",345678}
};
```

When indexed by a value of its first type (called the *key*), a **map** returns the corresponding value of the second type (called the *value* or the *mapped type*). For example:

```
int get_number(const string& s)
{
    return phone_book[s];
}
```

In other words, subscripting a **map** is essentially the lookup we called **get_number()**. If a **key** isn't found, it is entered into the **map** with a default value for its **value**. The default value for an integer type is **0**; the value I just happened to choose represents an invalid telephone number.

If we wanted to avoid entering invalid numbers into our phone book, we could use **find()** and **insert()** instead of **[]**.

11.5 unordered_map

The cost of a **map** lookup is $O(\log(n))$ where **n** is the number of elements in the **map**. That's pretty good. For example, for a **map** with 1,000,000 elements, we perform only about 20 comparisons and indirections to find an element. However, in many cases, we can do better by using a hashed

lookup rather than a comparison using an ordering function, such as `<`. The standard-library hashed containers are referred to as “unordered” because they don’t require an ordering function:

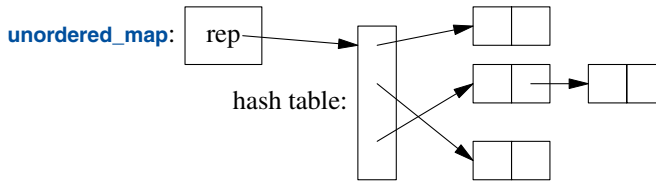

For example, we can use an `unordered_map` from `<unordered_map>` for our phone book:

```
unordered_map<string,int> phone_book {
    {"David Hume",123456},
    {"Karl Popper",234567},
    {"Bertrand Arthur William Russell",345678}
};
```

Like for a `map`, we can subscript an `unordered_map`:

```
int get_number(const string& s)
{
    return phone_book[s];
}
```

The standard library provides a default hash function for `strings` as well as for other built-in and standard-library types. If necessary, you can provide your own (§5.4.6). Possibly, the most common need for a “custom” hash function comes when we want an unordered container of one of our own types. A hash function is often provided as a function object (§6.3.2). For example:

```
struct Record {
    string name;
    int product_code;
    // ...
};

struct Rhash { // a hash function for Record
    size_t operator()(const Record& r) const
    {
        return hash<string>(r.name) ^ hash<int>(r.product_code);
    }
};

unordered_set<Record,Rhash> my_set; // set of Records using Rhash for lookup
```

Designing good hash functions is an art and sometimes requires knowledge of the data to which it will be applied. Creating a new hash function by combining existing hash functions using exclusive-or (`^`) is simple and often very effective.

We can avoid explicitly passing the `hash` operation by defining it as a specialization of the standard-library `hash`:

```

namespace std { // make a hash function for Record

    template<> struct hash<Record> {
        using argument_type = Record;
        using result_type = std::size_t;

        size_t operator()(const Record& r) const
        {
            return hash<string>()(r.name) ^ hash<int>()(r.product_code);
        }
    };
}

```

Note the differences between a **map** and an **unordered_map**:

- A **map** requires an ordering function (the default is `<`) and yields an ordered sequence.
- A **unordered_map** requires an equality function (the default is `==`); it does not maintain an order among its elements.

Given a good hash function, an **unordered_map** is much faster than a **map** for large containers. However, the worst-case behavior of an **unordered_map** with a poor hash function is far worse than that of a **map**.

11.6 Container Overview

The standard library provides some of the most general and useful container types to allow the programmer to select a container that best serves the needs of an application:

Standard Container Summary	
<code>vector<T></code>	A variable-size vector (§11.2)
<code>list<T></code>	A doubly-linked list (§11.3)
<code>forward_list<T></code>	A singly-linked list
<code>deque<T></code>	A double-ended queue
<code>set<T></code>	A set (a map with just a key and no value)
<code>multiset<T></code>	A set in which a value can occur many times
<code>map<K,V></code>	An associative array (§11.4)
<code>multimap<K,V></code>	A map in which a key can occur many times
<code>unordered_map<K,V></code>	A map using a hashed lookup (§11.5)
<code>unordered_multimap<K,V></code>	A multimap using a hashed lookup
<code>unordered_set<T></code>	A set using a hashed lookup
<code>unordered_multiset<T></code>	A multiset using a hashed lookup

The unordered containers are optimized for lookup with a key (often a string); in other words, they are implemented using hash tables.

The containers are defined in namespace `std` and presented in headers `<vector>`, `<list>`, `<map>`, etc. (§8.3). In addition, the standard library provides container adaptors `queue<T>`, `stack<T>`, and `priority_queue<T>`. Look them up if you need them. The standard library also provides more

specialized container-like types, such as `array<T,N>` (§13.4.1) and `bitset<N>` (§13.4.2).

The standard containers and their basic operations are designed to be similar from a notational point of view. Furthermore, the meanings of the operations are equivalent for the various containers. Basic operations apply to every kind of container for which they make sense and can be efficiently implemented:

Standard Container Operations (partial)	
<code>value_type</code>	The type of an element
<code>p=c.begin()</code>	<code>p</code> points to first element of <code>c</code> ; also <code>cbegin()</code> for an iterator to <code>const</code>
<code>p=c.end()</code>	<code>p</code> points to one-past-the-last element of <code>c</code> ; also <code>cend()</code> for an iterator to <code>const</code>
<code>k=c.size()</code>	<code>k</code> is the number of elements in <code>c</code>
<code>c.empty()</code>	Is <code>c</code> empty?
<code>k=c.capacity()</code>	<code>k</code> is the number of elements that <code>c</code> can hold without a new allocation
<code>c.reserve(k)</code>	Make the capacity <code>k</code>
<code>c.resize(k)</code>	Make the number of elements <code>k</code> ; added elements has the value <code>value_type{}</code>
<code>c[k]</code>	The <code>k</code> th element of <code>c</code> ; no range checking
<code>c.at(k)</code>	The <code>k</code> th element of <code>c</code> ; if out of range, throw <code>out_of_range</code>
<code>c.push_back(x)</code>	Add <code>x</code> at the end of <code>c</code> ; increase the size of <code>c</code> by one
<code>c.emplace_back(a)</code>	Add <code>value_type{a}</code> at the end of <code>c</code> ; increase the size of <code>c</code> by one
<code>q=c.insert(p,x)</code>	Add <code>x</code> before <code>p</code> in <code>c</code>
<code>q=c.erase(p)</code>	Remove element at <code>p</code> from <code>c</code>
<code>c=c2</code>	Assignment
<code>b=(c==c2)</code> , also <code>!=</code>	Equality of all elements of <code>c</code> and <code>c2</code> ; <code>b==true</code> if equal
<code>x=(c<c2)</code> , also <code><=</code> , <code>></code> , <code>>=</code>	Lexicographical order of <code>c</code> and <code>c2</code> : <code>x<0</code> if less than, <code>x==0</code> if equal, and <code>0<x</code> if greater than

This notational and semantic uniformity enables programmers to provide new container types that can be used in a very similar manner to the standard ones. The range-checked vector, `Vector` (§3.5.2, Chapter 4), is an example of that. The uniformity of container interfaces allows us to specify algorithms independently of individual container types. However, each has strengths and weaknesses. For example, subscripting and traversing a `vector` is cheap and easy. On the other hand, `vector` elements are moved when we insert or remove elements; `list` has exactly the opposite properties. Please note that a `vector` is usually more efficient than a `list` for short sequences of small elements (even for `insert()` and `erase()`). I recommend the standard-library `vector` as the default type for sequences of elements: you need a reason to choose another.

Consider the singly-linked list, `forward_list`, a container optimized for the empty sequence (§11.3). An empty `forward_list` occupies just one word, whereas an empty `vector` occupy three. Empty sequences, and sequences with only an element or two, are surprisingly common and useful.

An `emplace` operation, such as `emplace_back()` takes arguments for an element's constructor and builds the object in a newly allocated space in the container, rather than copying an object into the container. For example, for a `vector<pair<int,string>>` we could write:

```
v.push_back(pair{1,"copy or move"}); // make a pair and move it into v
v.emplace_back(1,"build in place"); // build a pair in v
```

11.7 Advice

- [1] An STL container defines a sequence; §11.2.
- [2] STL containers are resource handles; §11.2, §11.3, §11.4, §11.5.
- [3] Use **vector** as your default container; §11.2, §11.6; [CG: SL.con.2].
- [4] For simple traversals of a container, use a range-**for** loop or a begin/end pair of iterators; §11.2, §11.3.
- [5] Use **reserve()** to avoid invalidating pointers and iterators to elements; §11.2.
- [6] Don't assume performance benefits from **reserve()** without measurement; §11.2.
- [7] Use **push_back()** or **resize()** on a container rather than **realloc()** on an array; §11.2.
- [8] Don't use iterators into a resized **vector**; §11.2.
- [9] Do not assume that `[]` range checks; §11.2.
- [10] Use **at()** when you need guaranteed range checks; §11.2; [CG: SL.con.3].
- [11] Use range-**for** and standard-library algorithms for cost-free avoidance of range errors; §11.2.2.
- [12] Elements are copied into a container; §11.2.1.
- [13] To preserve polymorphic behavior of elements, store pointers; §11.2.1.
- [14] Insertion operations, such as **insert()** and **push_back()**, are often surprisingly efficient on a **vector**; §11.3.
- [15] Use **forward_list** for sequences that are usually empty; §11.6.
- [16] When it comes to performance, don't trust your intuition: measure; §11.2.
- [17] A **map** is usually implemented as a red-black tree; §11.4.
- [18] An **unordered_map** is a hash table; §11.5.
- [19] Pass a container by reference and return a container by value; §11.2.
- [20] For a container, use the `()`-initializer syntax for sizes and the `{}`-initializer syntax for lists of elements; §4.2.3, §11.2.
- [21] Prefer compact and contiguous data structures; §11.3.
- [22] A **list** is relatively expensive to traverse; §11.3.
- [23] Use unordered containers if you need fast lookup for large amounts of data; §11.5.
- [24] Use ordered associative containers (e.g., **map** and **set**) if you need to iterate over their elements in order; §11.4.
- [25] Use unordered containers for element types with no natural order (e.g., no reasonable `<`); §11.4.
- [26] Experiment to check that you have an acceptable hash function; §11.5.
- [27] A hash function obtained by combining standard hash functions for elements using the exclusive-or operator (`^`) is often good; §11.5.
- [28] Know your standard-library containers and prefer them to handcrafted data structures; §11.6.

12

Algorithms

Do not multiply entities beyond necessity.
– William Occam

- Introduction
- Use of Iterators
- Iterator Types
- Stream Iterators
- Predicates
- Algorithm Overview
- Concepts
- Container Algorithms
- Parallel Algorithms
- Advice

12.1 Introduction

A data structure, such as a list or a vector, is not very useful on its own. To use one, we need operations for basic access such as adding and removing elements (as is provided for **list** and **vector**). Furthermore, we rarely just store objects in a container. We sort them, print them, extract subsets, remove elements, search for objects, etc. Consequently, the standard library provides the most common algorithms for containers in addition to providing the most common container types. For example, we can simply and efficiently sort a **vector** of **Entry**s and place a copy of each unique **vector** element on a **list**:

```
void f(vector<Entry>& vec, list<Entry>& lst)
{
    sort(vec.begin(),vec.end());           // use < for order
    unique_copy(vec.begin(),vec.end(),lst.begin()); // don't copy adjacent equal elements
}
```

For this to work, less than (<) and equal (==) must be defined for **Entry**. For example:

```
bool operator<(const Entry& x, const Entry& y)    // less than
{
    return x.name<y.name;                       // order Entries by their names
}
```

A standard algorithm is expressed in terms of (half-open) sequences of elements. A *sequence* is represented by a pair of iterators specifying the first element and the one-beyond-the-last element:

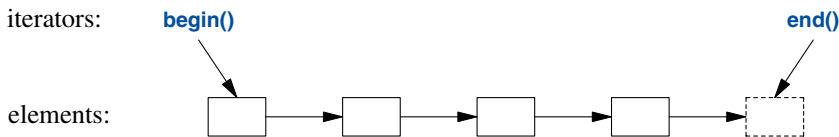

In the example, **sort()** sorts the sequence defined by the pair of iterators **vec.begin()** and **vec.end()**, which just happens to be all the elements of a **vector**. For writing (output), you need only to specify the first element to be written. If more than one element is written, the elements following that initial element will be overwritten. Thus, to avoid errors, **lst** must have at least as many elements as there are unique values in **vec**.

If we wanted to place the unique elements in a new container, we could have written:

```
list<Entry> f(vector<Entry>& vec)
{
    list<Entry> res;
    sort(vec.begin(),vec.end());
    unique_copy(vec.begin(),vec.end(),back_inserter(res));    // append to res
    return res;
}
```

The call **back_inserter(res)** constructs an iterator for **res** that adds elements at the end of a container, extending the container to make room for them. This saves us from first having to allocate a fixed amount of space and then filling it. Thus, the standard containers plus **back_inserter()**s eliminate the need to use error-prone, explicit C-style memory management using **realloc()**. The standard-library **list** has a move constructor (§5.2.2) that makes returning **res** by value efficient (even for **lists** of thousands of elements).

If you find the pair-of-iterators style of code, such as **sort(vec.begin(),vec.end())**, tedious, you can define container versions of the algorithms and write **sort(vec)** (§12.8).

12.2 Use of Iterators

For a container, a few iterators referring to useful elements can be obtained; **begin()** and **end()** are the best examples of this. In addition, many algorithms return iterators. For example, the standard algorithm **find** looks for a value in a sequence and returns an iterator to the element found:

```

bool has_c(const string& s, char c)    // does s contain the character c?
{
    auto p = find(s.begin(),s.end(),c);
    if (p!=s.end())
        return true;
    else
        return false;
}

```

Like many standard-library search algorithms, `find` returns `end()` to indicate “not found.” An equivalent, shorter, definition of `has_c()` is:

```

bool has_c(const string& s, char c)    // does s contain the character c?
{
    return find(s.begin(),s.end(),c)!=s.end();
}

```

A more interesting exercise would be to find the location of all occurrences of a character in a string. We can return the set of occurrences as a `vector` of `string` iterators. Returning a `vector` is efficient because `vector` provides move semantics (§5.2.1). Assuming that we would like to modify the locations found, we pass a non-`const` string:

```

vector<string::iterator> find_all(string& s, char c)    // find all occurrences of c in s
{
    vector<string::iterator> res;
    for (auto p = s.begin(); p!=s.end(); ++p)
        if (*p==c)
            res.push_back(p);
    return res;
}

```

We iterate through the string using a conventional loop, moving the iterator `p` forward one element at a time using `++` and looking at the elements using the dereference operator `*`. We could test `find_all()` like this:

```

void test()
{
    string m {"Mary had a little lamb"};
    for (auto p : find_all(m,'a'))
        if (*p=='a')
            cerr << "a bug!\n";
}

```

That call of `find_all()` could be graphically represented like this:

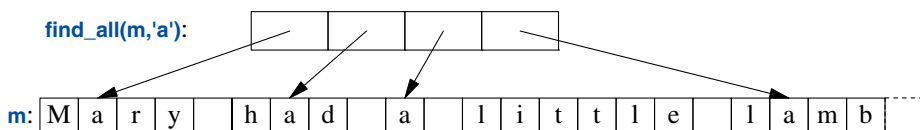

Iterators and standard algorithms work equivalently on every standard container for which their use makes sense. Consequently, we could generalize `find_all()`:

```
template<typename C, typename V>
vector<typename C::iterator> find_all(C& c, V v)      // find all occurrences of v in c
{
    vector<typename C::iterator> res;
    for (auto p = c.begin(); p!=c.end(); ++p)
        if (*p==v)
            res.push_back(p);
    return res;
}
```

The `typename` is needed to inform the compiler that `C`'s `iterator` is supposed to be a type and not a value of some type, say, the integer `7`. We can hide this implementation detail by introducing a type alias (§6.4.2) for `Iterator`:

```
template<typename T>
using Iterator = typename T::iterator;           // T's iterator

template<typename C, typename V>
vector<Iterator<C>> find_all(C& c, V v)          // find all occurrences of v in c
{
    vector<Iterator<C>> res;
    for (auto p = c.begin(); p!=c.end(); ++p)
        if (*p==v)
            res.push_back(p);
    return res;
}
```

We can now write:

```
void test()
{
    string m {"Mary had a little lamb"};

    for (auto p : find_all(m,'a'))           // p is a string::iterator
        if (*p=='a')
            cerr << "string bug!\n";

    list<double> ld {1.1, 2.2, 3.3, 1.1};
    for (auto p : find_all(ld,1.1))         // p is a list<double>::iterator
        if (*p==1.1)
            cerr << "list bug!\n";

    vector<string> vs { "red", "blue", "green", "green", "orange", "green" };
    for (auto p : find_all(vs,"red"))      // p is a vector<string>::iterator
        if (*p=="red")
            cerr << "vector bug!\n";
}
```

```

for (auto p : find_all(vs,"green"))
    *p = "vert";
}
    
```

Iterators are used to separate algorithms and containers. An algorithm operates on its data through iterators and knows nothing about the container in which the elements are stored. Conversely, a container knows nothing about the algorithms operating on its elements; all it does is to supply iterators upon request (e.g., `begin()` and `end()`). This model of separation between data storage and algorithm delivers very general and flexible software.

12.3 Iterator Types

What are iterators really? Any particular iterator is an object of some type. There are, however, many different iterator types, because an iterator needs to hold the information necessary for doing its job for a particular container type. These iterator types can be as different as the containers and the specialized needs they serve. For example, a `vector`'s iterator could be an ordinary pointer, because a pointer is quite a reasonable way of referring to an element of a `vector`:

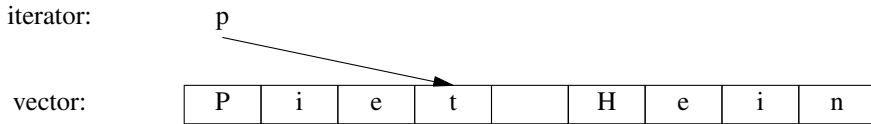

Alternatively, a `vector` iterator could be implemented as a pointer to the `vector` plus an index:

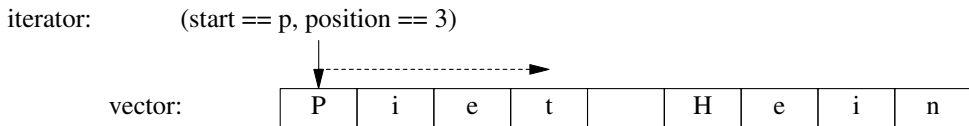

Using such an iterator would allow range checking.

A `list` iterator must be something more complicated than a simple pointer to an element because an element of a `list` in general does not know where the next element of that `list` is. Thus, a `list` iterator might be a pointer to a link:

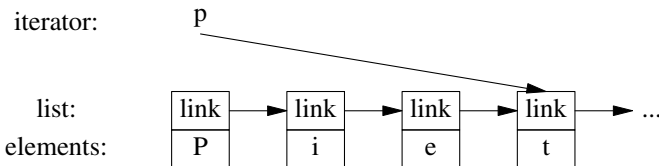

What is common for all iterators is their semantics and the naming of their operations. For example, applying `++` to any iterator yields an iterator that refers to the next element. Similarly, `*` yields

the element to which the iterator refers. In fact, any object that obeys a few simple rules like these is an iterator – *Iterator* is a concept (§7.2, §12.7). Furthermore, users rarely need to know the type of a specific iterator; each container “knows” its iterator types and makes them available under the conventional names `iterator` and `const_iterator`. For example, `list<Entry>::iterator` is the general iterator type for `list<Entry>`. We rarely have to worry about the details of how that type is defined.

12.4 Stream Iterators

Iterators are a general and useful concept for dealing with sequences of elements in containers. However, containers are not the only place where we find sequences of elements. For example, an input stream produces a sequence of values, and we write a sequence of values to an output stream. Consequently, the notion of iterators can be usefully applied to input and output.

To make an `ostream_iterator`, we need to specify which stream will be used and the type of objects written to it. For example:

```
ostream_iterator<string> oo {cout};    // write strings to cout
```

The effect of assigning to `*oo` is to write the assigned value to `cout`. For example:

```
int main()
{
    *oo = "Hello, ";    // meaning cout<<"Hello, "
    ++oo;
    *oo = "world!\n";  // meaning cout<<"world!\n"
}
```

This is yet another way of writing the canonical message to standard output. The `++oo` is done to mimic writing into an array through a pointer.

Similarly, an `istream_iterator` is something that allows us to treat an input stream as a read-only container. Again, we must specify the stream to be used and the type of values expected:

```
istream_iterator<string> ii {cin};
```

Input iterators are used in pairs representing a sequence, so we must provide an `istream_iterator` to indicate the end of input. This is the default `istream_iterator`:

```
istream_iterator<string> eos {};
```

Typically, `istream_iterators` and `ostream_iterators` are not used directly. Instead, they are provided as arguments to algorithms. For example, we can write a simple program to read a file, sort the words read, eliminate duplicates, and write the result to another file:

```
int main()
{
    string from, to;
    cin >> from >> to;                // get source and target file names

    ifstream is {from};                // input stream for file "from"
    istream_iterator<string> ii {is};   // input iterator for stream
    istream_iterator<string> eos {};    // input sentinel
}
```

```

    ofstream os {to};           // output stream for file "to"
    ostream_iterator<string> oo {os, "\n"}; // output iterator for stream

    vector<string> b {ii, eos}; // b is a vector initialized from input
    sort(b.begin(), b.end());  // sort the buffer

    unique_copy(b.begin(), b.end(), oo); // copy buffer to output, discard replicated values

    return !is.eof() || !os;      // return error state (§1.2.1, §10.4)
}

```

An **ifstream** is an **istream** that can be attached to a file, and an **ofstream** is an **ostream** that can be attached to a file (§10.7). The **ostream_iterator**'s second argument is used to delimit output values.

Actually, this program is longer than it needs to be. We read the strings into a **vector**, then we **sort()** them, and then we write them out, eliminating duplicates. A more elegant solution is not to store duplicates at all. This can be done by keeping the **strings** in a **set**, which does not keep duplicates and keeps its elements in order (§11.4). That way, we could replace the two lines using a **vector** with one using a **set** and replace **unique_copy()** with the simpler **copy()**:

```

    set<string> b {ii, eos}; // collect strings from input
    copy(b.begin(), b.end(), oo); // copy buffer to output

```

We used the names **ii**, **eos**, and **oo** only once, so we could further reduce the size of the program:

```

int main()
{
    string from, to;
    cin >> from >> to; // get source and target file names

    ifstream is {from}; // input stream for file "from"
    ofstream os {to};   // output stream for file "to"

    set<string> b {istream_iterator<string>{is}, istream_iterator<string>{}}; // read input
    copy(b.begin(), b.end(), ostream_iterator<string>{os, "\n"}); // copy to output

    return !is.eof() || !os; // return error state (§1.2.1, §10.4)
}

```

It is a matter of taste and experience whether or not this last simplification improves readability.

12.5 Predicates

In the examples so far, the algorithms have simply “built in” the action to be done for each element of a sequence. However, we often want to make that action a parameter to the algorithm. For example, the **find** algorithm (§12.2, §12.6) provides a convenient way of looking for a specific value. A more general variant looks for an element that fulfills a specified requirement, a *predicate*. For example, we might want to search a **map** for the first value larger than **42**. A **map** allows us to access its elements as a sequence of (*key, value*) pairs, so we can search a **map<string, int>**'s sequence for a **pair<const string, int>** where the **int** is greater than **42**:

```
void f(map<string,int>& m)
{
    auto p = find_if(m.begin(),m.end(),Greater_than{42});
    // ...
}
```

Here, `Greater_than` is a function object (§6.3.2) holding the value (42) to be compared against:

```
struct Greater_than {
    int val;
    Greater_than(int v) : val{v} {}
    bool operator()(const pair<string,int>& r) const { return r.second>val; }
};
```

Alternatively, we could use a lambda expression (§6.3.2):

```
auto p = find_if(m.begin(), m.end(), [](const auto& r) { return r.second>42; });
```

A predicate should not modify the elements to which it is applied.

12.6 Algorithm Overview

A general definition of an algorithm is “a finite set of rules which gives a sequence of operations for solving a specific set of problems [and] has five important features: Finiteness ... Definiteness ... Input ... Output ... Effectiveness” [Knuth,1968,§1.1]. In the context of the C++ standard library, an algorithm is a function template operating on sequences of elements.

The standard library provides dozens of algorithms. The algorithms are defined in namespace `std` and presented in the `<algorithm>` header. These standard-library algorithms all take sequences as inputs. A half-open sequence from `b` to `e` is referred to as `[b:e)`. Here are a few examples:

Selected Standard Algorithms <code><algorithm></code>	
<code>f=for_each(b,e,f)</code>	For each element <code>x</code> in <code>[b:e)</code> do <code>f(x)</code>
<code>p=find(b,e,x)</code>	<code>p</code> is the first <code>p</code> in <code>[b:e)</code> so that <code>*p==x</code>
<code>p=find_if(b,e,f)</code>	<code>p</code> is the first <code>p</code> in <code>[b:e)</code> so that <code>f(*p)</code>
<code>n=count(b,e,x)</code>	<code>n</code> is the number of elements <code>*q</code> in <code>[b:e)</code> so that <code>*q==x</code>
<code>n=count_if(b,e,f)</code>	<code>n</code> is the number of elements <code>*q</code> in <code>[b:e)</code> so that <code>f(*q)</code>
<code>replace(b,e,v,v2)</code>	Replace elements <code>*q</code> in <code>[b:e)</code> so that <code>*q==v</code> with <code>v2</code>
<code>replace_if(b,e,f,v2)</code>	Replace elements <code>*q</code> in <code>[b:e)</code> so that <code>f(*q)</code> with <code>v2</code>
<code>p=copy(b,e,out)</code>	Copy <code>[b:e)</code> to <code>[out:p)</code>
<code>p=copy_if(b,e,out,f)</code>	Copy elements <code>*q</code> from <code>[b:e)</code> so that <code>f(*q)</code> to <code>[out:p)</code>
<code>p=move(b,e,out)</code>	Move <code>[b:e)</code> to <code>[out:p)</code>
<code>p=unique_copy(b,e,out)</code>	Copy <code>[b:e)</code> to <code>[out:p)</code> ; don't copy adjacent duplicates
<code>sort(b,e)</code>	Sort elements of <code>[b:e)</code> using <code><</code> as the sorting criterion
<code>sort(b,e,f)</code>	Sort elements of <code>[b:e)</code> using <code>f</code> as the sorting criterion
<code>(p1,p2)=equal_range(b,e,v)</code>	<code>[p1:p2)</code> is the subsequence of the sorted sequence <code>[b:e)</code> with the value <code>v</code> ; basically a binary search for <code>v</code>

Selected Standard Algorithms <algorithm> (continued)	
<code>p=merge(b,e,b2,e2,out)</code>	Merge two sorted sequences [b:e] and [b2:e2] into [out:p]
<code>p=merge(b,e,b2,e2,out,f)</code>	Merge two sorted sequences [b:e] and [b2:e2] into [out:p] using <code>f</code> as the comparison

These algorithms, and many more (e.g., §14.3), can be applied to elements of containers, **strings**, and built-in arrays.

Some algorithms, such as `replace()` and `sort()`, modify element values, but no algorithm adds or subtracts elements of a container. The reason is that a sequence does not identify the container that holds the elements of the sequence. To add or delete elements, you need something that knows about the container (e.g., a `back_inserter`; §12.1) or directly refers to the container itself (e.g., `push_back()` or `erase()`; §11.2).

Lambdas are very common as operations passed as arguments. For example:

```
vector<int> v = {0,1,2,3,4,5};
for_each(v.begin(),v.end(),[](int& x){ x=x*x; }); // v=={0,1,4,9,16,25}
```

The standard-library algorithms tend to be more carefully designed, specified, and implemented than the average hand-crafted loop, so know them and use them in preference to code written in the bare language.

12.7 Concepts (C++20)

In C++20, the standard-library algorithms will be specified using concepts (Chapter 7). The preliminary work on this can be found in the Ranges Technical Specification [RangesTS]. Implementations can be found on the Web. For C++20, the ranges concepts are defined in `<ranges>`.

Range is a generalization of the C++98 sequences defined by `begin()/end()` pairs. **Range** is a concept specifying what it takes to be a sequence of elements. It can be defined by

- A `{begin,end}` pair of iterators
- A `{begin,n}` pair, where `begin` is an iterator and `n` is the number of elements
- A `{begin,pred}` pair, where `begin` is an iterator and `pred` is a predicate; if `pred(p)` is `true` for the iterator `p`, we have reached the end of the sequence. This allows us to have infinite sequences and sequences that are generated “on the fly.”

This **Range** concept is what allows us to say `sort(v)` rather than `sort(v.begin(),v.end())` as we had to using the STL since 1994. For example:

```
template<BoundedRange R>
    requires Sortable<R>
void sort(R& r)
{
    return sort(begin(r),end(r));
}
```

The relation for `Sortable` is defaulted to `less`.

In general, where a standard-library algorithm requires a sequence defined by a pair of iterators, C++20 will allow a **Range** as a notationally simpler alternative.

In addition to `Range`, C++20 offers many useful concepts. These concepts are found in the headers `<ranges>`, `<iterator>`, and `<concepts>`.

Core language concepts <code><concepts></code>	
<code>Same<T,U></code>	<code>T</code> is the same type as <code>U</code>
<code>DerivedFrom<T,U></code>	<code>T</code> is derived from <code>U</code>
<code>ConvertibleTo<T,U></code>	A <code>T</code> can be converted to a <code>U</code>
<code>CommonReference<T,U></code>	<code>T</code> and <code>U</code> share a common reference type
<code>Common<T,U></code>	<code>T</code> and <code>U</code> share a common type
<code>Integral<T></code>	<code>T</code> is an integral type
<code>SignedIntegral<T></code>	<code>T</code> is a signed integral type
<code>UnsignedIntegral<T></code>	<code>T</code> is an unsigned integral type
<code>Assignable<T,U></code>	A <code>U</code> can be assigned to a <code>T</code>
<code>SwappableWith<T,U></code>	A <code>T</code> can be swapped with a <code>U</code>
<code>Swappable<T></code>	<code>SwappableWith<T,T></code>

`Common` is important for specifying algorithms that should work with a variety of related types while still being mathematically sound. `Common<T,U>` is a type `C` that we can use for comparing a `T` with a `U` by first converting both to `C`s. For example, we would like to compare a `std::string` with a C-style string (a `char*`) and an `int` with a `double`, but not a `std::string` with an `int`. To ensure that we specialize `common_type_t`, used in the definition of `Common`, suitably:

```
using common_type_t<std::string,char*> = std::string;
using common_type_t<double,int> = double;
```

The definition of `Common` is a bit tricky but solves a hard fundamental problem. Fortunately, we don't need to define a `common_type_t` specialization unless we want to use operations on mixes of types for which a library doesn't (yet) have suitable definitions. `Common` or `CommonReference` is used in the definitions of most concepts and algorithms that can compare values of different types.

The concepts related to comparison are strongly influenced by [Stepanov,2009].

Comparison concepts <code><concepts></code>	
<code>Boolean<T></code>	A <code>T</code> can be used as a Boolean
<code>WeaklyEqualityComparableWith<T,U></code>	A <code>T</code> and a <code>U</code> can be compared for equality using <code>==</code> and <code>!=</code>
<code>WeaklyEqualityComparable<T></code>	<code>WeaklyEqualityComparableWith<T,T></code>
<code>EqualityComparableWith<T,U></code>	A <code>T</code> and a <code>U</code> can be compared for equivalence using <code>==</code>
<code>EqualityComparable<T></code>	<code>EqualityComparableWith<T,T></code>
<code>StrictTotallyOrderedWith<T,U></code>	A <code>T</code> and a <code>U</code> can be compared using <code><</code> , <code><=</code> , <code>></code> , and <code>>=</code> yielding a total order
<code>StrictTotallyOrdered<T></code>	<code>StrictTotallyOrderedWith<T,T></code>

The use of both `WeaklyEqualityComparableWith` and `WeaklyEqualityComparable` shows a (so far) missed opportunity to overload.

Object concepts <concepts>	
Destructible <T>	A T can be destroyed and have its address taken with unary &
Constructible <T,Args>	A T can be constructed from an argument list of type Args
DefaultConstructible <T>	A T can be default constructed
MoveConstructible <T>	A T can be move constructed
CopyConstructible <T>	A T can be copy constructed and move constructed
Movable <T>	MoveConstructible <T>, Assignable <T&,T>, and Swappable <T>
Copyable <T>	CopyConstructible <T>, Moveable <T>, and Assignable <T, const T&>
SemiRegular <T>	Copyable <T> and DefaultConstructible <T>
Regular <T>	SemiRegular <T> and EqualityComparable <T>

Regular is the ideal for types. A **Regular** type works roughly like an **int** and simplifies much of our thinking about how to use a type (§7.2). The lack of default **==** for classes means that most classes start out as **SemiRegular** even though most could and should be **Regular**.

Callable concepts <concepts>	
Invocable <F,Args>	An F can be invoked with an argument list of type Args
InvocableRegular <F,Args>	Invocable <F,Args> and is equality preserving
Predicate <F,Args>	An F can be invoked with an argument list of type Args returning a bool
Relation <F,T,U>	Predicate <F,T,U>
StrictWeakOrder <F,T,U>	A Relation <F,T,U> that provides strict weak ordering

A function **f()** is *equality preserving* if **x==y** implies that **f(x)==f(y)**.

Strict weak ordering is what the standard library usually assumes for comparisons, such as **<**; look it up if you feel the need to know.

Relation and **StrictWeakOrder** differ only in semantics. We can't (currently) represent that in code so the names simply express our intent.

Iterator concepts <iterators>	
Iterator <I>	An I can be incremented (++) and dereferenced (*)
Sentinel <S,I>	An S is a sentinel for an Iterator type; that is, S is a predicate on I 's value type
SizedSentinel <S,I>	A sentinel S where the - operator can be applied to I
InputIterator <I>	An I is an input iterator; * can be used for reading only
OutputIterator <I>	An I is an output iterator; * can be used for writing only
ForwardIterator <I>	An I is a forward iterator, supporting multi-pass
BidirectionalIterator <I>	An I is a ForwardIterator supporting --
RandomAccessIterator <I>	An I is a BidirectionalIterator supporting + , - , ++ , -- , and []
Permutable <I>	An I is a ForwardIterator <I> where I allows us to move and swap elements
Mergeable <I1,I2,R,O>	Can merge sorted sequences defined by I1 and I2 into O using Relation <R>
Sortable <I>	Can sort sequences defined by I using less
Sortable <I,R>	Can sort sequences defined by I using Relation <R>

The different kinds (categories) of iterators are used to select the best algorithm for a given algorithm; see §7.2.2 and §13.9.1. For an example of an **InputIterator**, see §12.4.

The basic idea of a sentinel is that we can iterate over a range starting at an iterator until the predicate becomes true for an element. That way, an iterator **p** and a sentinel **s** define a range [**p:s(*p)**). For example, we could define a predicate for a sentinel for traversing a C-style string using a pointer as the iterator:

```
[](const char* p) {return *p==0; }
```

The summary of **Mergeable** and **Sortable** are simplified relative to their definition in C++20.

Range concepts <ranges>	
Range <R>	An R is a range with a begin iterator and a sentinel
SizedRange <R>	An R is a range that knows its size in constant time
View <R>	An R is a range with constant time copy, move, and assignment
BoundedRange <R>	An R is a range with identical iterator and sentinel types
InputRange <R>	An R is a range whose iterator type satisfies InputIterator
OutputRange <R>	An R is a range whose iterator type satisfies OutputIterator
ForwardRange <R>	An R is a range whose iterator type satisfies ForwardIterator
BidirectionalRange <R>	An R is a range whose iterator type satisfies BidirectionalIterator
RandomAccessRange <R>	An R is a range whose iterator type satisfies RandomAccessIterator

There are a few more concepts in <ranges>, but this set is a good start.

12.8 Container Algorithms

When we can't wait for Ranges, we can define our own simple range algorithms. For example, we can easily provide the shorthand to say just **sort(v)** instead of **sort(v.begin(),v.end())**:

```
namespace Estd {
    using namespace std;

    template<typename C>
    void sort(C& c)
    {
        sort(c.begin(),c.end());
    }

    template<typename C, typename Pred>
    void sort(C& c, Pred p)
    {
        sort(c.begin(),c.end(),p);
    }

    // ...
}
```

I put the container versions of **sort()** (and other algorithms) into their own namespace **Estd**

(“extended `std`”) to avoid interfering with other programmers’ uses of namespace `std` and also to make it easier to replace this stopgap with `Ranges`.

12.9 Parallel Algorithms

When the same task is to be done to many data items, we can execute it in parallel on each data item provided the computations on different data items are independent:

- *parallel execution*: tasks are done on multiple threads (often running on several processor cores)
- *vectorized execution*: tasks are done on a single thread using vectorization, also known as *SIMD* (“Single Instruction, Multiple Data”).

The standard library offers support for both and we can be specific about wanting sequential execution; in `<execution>`, we find:

- `seq`: sequential execution
- `par`: parallel execution (if feasible)
- `par_unseq`: parallel and/or unsequenced (vectorized) execution (if feasible).

Consider `std::sort()`:

```
sort(v.begin(),v.end());           // sequential
sort(seq,v.begin(),v.end());      // sequential (same as the default)
sort(par,v.begin(),v.end());      // parallel
sort(par_unseq,v.begin(),v.end()); // parallel and/or vectorized
```

Whether it is worthwhile to parallelize and/or vectorize depends on the algorithm, the number of elements in the sequence, the hardware, and the utilization of that hardware by programs running on it. Consequently, the *execution policy indicators* are just hints. A compiler and/or run-time scheduler will decide how much concurrency to use. This is all nontrivial and the rule against making statements about efficiency without measurement is very important here.

Most standard-library algorithms, including all in the table in §12.6 except `equal_range`, can be requested to be parallelized and vectorized using `par` and `par_unseq` as for `sort()`. Why not `equal_range()`? Because so far nobody has come up with a worthwhile parallel algorithm for that.

Many parallel algorithms are used primarily for numeric data; see §14.3.1.

When requesting parallel execution, be sure to avoid data races (§15.2) and deadlock (§15.5).

12.10 Advice

- [1] An STL algorithm operates on one or more sequences; §12.1.
- [2] An input sequence is half-open and defined by a pair of iterators; §12.1.
- [3] When searching, an algorithm usually returns the end of the input sequence to indicate “not found”; §12.2.
- [4] Algorithms do not directly add or subtract elements from their argument sequences; §12.2, §12.6.
- [5] When writing a loop, consider whether it could be expressed as a general algorithm; §12.2.

- [6] Use predicates and other function objects to give standard algorithms a wider range of meanings; §12.5, §12.6.
- [7] A predicate must not modify its argument; §12.5.
- [8] Know your standard-library algorithms and prefer them to hand-crafted loops; §12.6.
- [9] When the pair-of-iterators style becomes tedious, introduce a container/range algorithm; §12.8.

13

Utilities

The time you enjoy wasting is not wasted time.
– Bertrand Russell

- Introduction
- Resource Management
 - `unique_ptr` and `shared_ptr`; `move()` and `forward()`
- Range Checking: `span`
- Specialized Containers
 - `array`; `bitset`; `pair` and `tuple`
- Alternatives
 - `variant`; `optional`; `any`
- Time
- Function Adaption
 - Lambdas as Adaptors; `mem_fn()`; `function`
- Allocators
- Type Functions
 - `iterator_traits`; Type Predicates; `enable_if`
- Advice

13.1 Introduction

Not all standard-library components come as part of obviously labeled facilities, such as “containers” or “I/O.” This section gives a few examples of small, widely useful components. Such components (classes and templates) are often called *vocabulary types* because they are part of the common vocabulary we use to describe our designs and programs. Such library components often act as building blocks for more powerful library facilities, including other components of the standard library. A function or a type need not be complicated or closely tied to a mass of other functions and types to be useful.

<https://t.me/learningnets>

13.2 Resource Management

One of the key tasks of any nontrivial program is to manage resources. A resource is something that must be acquired and later (explicitly or implicitly) released. Examples are memory, locks, sockets, thread handles, and file handles. For a long-running program, failing to release a resource in a timely manner (“a leak”) can cause serious performance degradation and possibly even a miserable crash. Even for short programs, a leak can become an embarrassment, say by a resource shortage increasing the run time by orders of magnitude.

The standard library components are designed not to leak resources. To do this, they rely on the basic language support for resource management using constructor/destructor pairs to ensure that a resource doesn’t outlive an object responsible for it. The use of a constructor/destructor pair in **Vector** to manage the lifetime of its elements is an example (§4.2.2) and all standard-library containers are implemented in similar ways. Importantly, this approach interacts correctly with error handling using exceptions. For example, this technique is used for the standard-library lock classes:

```
mutex m; // used to protect access to shared data
// ...
void f()
{
    scoped_lock<mutex> lck {m}; // acquire the mutex m
    // ... manipulate shared data ...
}
```

A **thread** will not proceed until **lck**’s constructor has acquired the **mutex** (§15.5). The corresponding destructor releases the resources. So, in this example, **scoped_lock**’s destructor releases the **mutex** when the thread of control leaves **f()** (through a **return**, by “falling off the end of the function,” or through an exception throw).

This is an application of RAII (the “Resource Acquisition Is Initialization” technique; §4.2.2). RAII is fundamental to the idiomatic handling of resources in C++. Containers (such as **vector** and **map**, **string**, and **iostream**) manage their resources (such as file handles and buffers) similarly.

13.2.1 unique_ptr and shared_ptr

The examples so far take care of objects defined in a scope, releasing the resources they acquire at the exit from the scope, but what about objects allocated on the free store? In **<memory>**, the standard library provides two “smart pointers” to help manage objects on the free store:

- [1] **unique_ptr** to represent unique ownership
- [2] **shared_ptr** to represent shared ownership

The most basic use of these “smart pointers” is to prevent memory leaks caused by careless programming. For example:

```
void f(int i, int j)    // X* vs. unique_ptr<X>
{
    X* p = new X;           // allocate a new X
    unique_ptr<X> sp {new X}; // allocate a new X and give its pointer to unique_ptr
    // ...
}
```

```

    if (i<99) throw Z{};           // may throw an exception
    if (j<77) return;           // may return "early"
    // ... use p and sp ..
    delete p;                   // destroy *p
}

```

Here, we “forgot” to delete `p` if `i<99` or if `j<77`. On the other hand, `unique_ptr` ensures that its object is properly destroyed whichever way we exit `f()` (by throwing an exception, by executing `return`, or by “falling off the end”). Ironically, we could have solved the problem simply by *not* using a pointer and *not* using `new`:

```

void f(int i, int j)    // use a local variable
{
    X x;
    // ...
}

```

Unfortunately, overuse of `new` (and of pointers and references) seems to be an increasing problem.

However, when you really need the semantics of pointers, `unique_ptr` is a very lightweight mechanism with no space or time overhead compared to correct use of a built-in pointer. Its further uses include passing free-store allocated objects in and out of functions:

```

unique_ptr<X> make_X(int i)
    // make an X and immediately give it to a unique_ptr
{
    // ... check i, etc. ...
    return unique_ptr<X>{new X{i}};
}

```

A `unique_ptr` is a handle to an individual object (or an array) in much the same way that a `vector` is a handle to a sequence of objects. Both control the lifetime of other objects (using RAII) and both rely on move semantics to make `return` simple and efficient.

The `shared_ptr` is similar to `unique_ptr` except that `shared_ptr`s are copied rather than moved. The `shared_ptr`s for an object share ownership of an object; that object is destroyed when the last of its `shared_ptr`s is destroyed. For example:

```

void f(shared_ptr<fstream>);
void g(shared_ptr<fstream>);

void user(const string& name, ios_base::openmode mode)
{
    shared_ptr<fstream> fp {new fstream(name,mode)};
    if (!*fp)                // make sure the file was properly opened
        throw No_file{};

    f(fp);
    g(fp);
    // ...
}

```

Now, the file opened by `fp`'s constructor will be closed by the last function to (explicitly or implicitly) destroy a copy of `fp`. Note that `f()` or `g()` may spawn a task holding a copy of `fp` or in some other way store a copy that outlives `user()`. Thus, `shared_ptr` provides a form of garbage collection that respects the destructor-based resource management of the memory-managed objects. This is neither cost free nor exorbitantly expensive, but it does make the lifetime of the shared object hard to predict. Use `shared_ptr` only if you actually need shared ownership.

Creating an object on the free store and then passing the pointer to it to a smart pointer is a bit verbose. It also allows for mistakes, such as forgetting to pass a pointer to a `unique_ptr` or giving a pointer to something that is not on the free store to a `shared_ptr`. To avoid such problems, the standard library (in `<memory>`) provides functions for constructing an object and returning an appropriate smart pointer, `make_shared()` and `make_unique()`. For example:

```
struct S {
    int i;
    string s;
    double d;
    // ...
};

auto p1 = make_shared<S>(1,"Ankh Morpork",4.65);    // p1 is a shared_ptr<S>
auto p2 = make_unique<S>(2,"Oz",7.62);           // p2 is a unique_ptr<S>
```

Now, `p2` is a `unique_ptr<S>` pointing to a free-store-allocated object of type `S` with the value `{2,"Oz"s,7.62}`.

Using `make_shared()` is not just more convenient than separately making an object using `new` and then passing it to a `shared_ptr`, it is also notably more efficient because it does not need a separate allocation for the use count that is essential in the implementation of a `shared_ptr`.

Given `unique_ptr` and `shared_ptr`, we can implement a complete “no naked `new`” policy (§4.2.2) for many programs. However, these “smart pointers” are still conceptually pointers and therefore only my second choice for resource management – after containers and other types that manage their resources at a higher conceptual level. In particular, `shared_ptr`s do not in themselves provide any rules for which of their owners can read and/or write the shared object. Data races (§15.7) and other forms of confusion are not addressed simply by eliminating the resource management issues.

Where do we use “smart pointers” (such as `unique_ptr`) rather than resource handles with operations designed specifically for the resource (such as `vector` or `thread`)? Unsurprisingly, the answer is “when we need pointer semantics.”

- When we share an object, we need pointers (or references) to refer to the shared object, so a `shared_ptr` becomes the obvious choice (unless there is an obvious single owner).
- When we refer to a polymorphic object in classical object-oriented code (§4.5), we need a pointer (or a reference) because we don't know the exact type of the object referred to (or even its size), so a `unique_ptr` becomes the obvious choice.
- A shared polymorphic object typically requires `shared_ptr`s.

We do *not* need to use a pointer to return a collection of objects from a function; a container that is a resource handle will do that simply and efficiently (§5.2.2).

13.2.2 move() and forward()

The choice between moving and copying is mostly implicit (§3.6). A compiler will prefer to move when an object is about to be destroyed (as in a `return`) because that's assumed to be the simpler and more efficient operation. However, sometimes we must be explicit. For example, a `unique_ptr` is the sole owner of an object. Consequently, it cannot be copied:

```
void f1()
{
    auto p = make_unique<int>(2);
    auto q = p;           // error: we can't copy a unique_ptr
    // ...
}
```

If you want a `unique_ptr` elsewhere, you must move it. For example:

```
void f1()
{
    auto p = make_unique<int>(2);
    auto q = move(p);    // p now holds nullptr
    // ...
}
```

Confusingly, `std::move()` doesn't move anything. Instead, it casts its argument to an rvalue reference, thereby saying that its argument will not be used again and therefore may be moved (§5.2.2). It should have been called something like `rvalue_cast`. Like other casts, it's error-prone and best avoided. It exists to serve a few essential cases. Consider a simple swap:

```
template <typename T>
void swap(T& a, T& b)
{
    T tmp {move(a)};    // the T constructor sees an rvalue and moves
    a = move(b);       // the T assignment sees an rvalue and moves
    b = move(tmp);     // the T assignment sees an rvalue and moves
}
```

We don't want to repeatedly copy potentially large objects, so we request moves using `std::move()`. Like for other casts, there are tempting, but dangerous, uses of `std::move()`. Consider:

```
string s1 = "Hello";
string s2 = "World";
vector<string> v;
v.push_back(s1);    // use a "const string&" argument; push_back() will copy
v.push_back(move(s2)); // use a move constructor
```

Here `s1` is copied (by `push_back()`) whereas `s2` is moved. This sometimes (only sometimes) makes the `push_back()` of `s2` cheaper. The problem is that a moved-from object is left behind. If we use `s2` again, we have a problem:

```
cout << s1[2];    // write 'l'
cout << s2[2];    // crash?
```

I consider this use of `std::move()` to be too error-prone for widespread use. Don't use it unless you

can demonstrate significant and necessary performance improvement. Later maintenance may accidentally lead to unanticipated use of the moved-from object.

The state of a moved-from object is in general unspecified, but all standard-library types leave a moved-from object in a state where it can be destroyed and assigned to. It would be unwise not to follow that lead. For a container (e.g., **vector** or **string**), the moved-from state will be “empty.” For many types, the default value is a good empty state: meaningful and cheap to establish.

Forwarding arguments is an important use case that requires moves (§7.4.2). We sometimes want to transmit a set of arguments on to another function without changing anything (to achieve “perfect forwarding”):

```
template<typename T, typename... Args>
unique_ptr<T> make_unique(Args&&... args)
{
    return unique_ptr<T>{new T{std::forward<Args>(args)...}}; // forward each argument
}
```

The standard-library **forward()** differs from the simpler **std::move()** by correctly handling subtleties to do with lvalue and rvalue (§5.2.2). Use **std::forward()** exclusively for forwarding and don’t **forward()** something twice; once you have forwarded an object, it’s not yours to use anymore.

13.3 Range Checking: **gsl::span**

Traditionally, range errors have been a major source of serious errors in C and C++ programs. The use of containers (Chapter 11), algorithms (Chapter 12), and range-**for** has significantly reduced this problem, but more can be done. A key source of range errors is that people pass pointers (raw or smart) and then rely on convention to know the number of elements pointed to. The best advice for code outside resource handles is to assume that at most one object is pointed to [CG: F.22], but without support that advice is unmanageable. The standard-library **string_view** (§9.3) can help, but that is read-only and for characters only. Most programmers need more.

The Core Guidelines [Stroustrup,2015] offer guidelines and a small Guidelines Support Library [GSL], including a **span** type for referring to a range of elements. This **span** is being proposed for the standard, but for now it is just something you can download if needed.

A **string_span** is basically a (pointer,length) pair denoting a sequence of elements:

```
span<int>:      { begin() , size() }
```

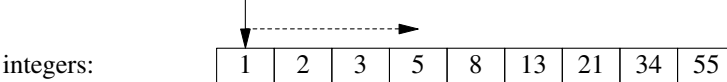

integers:

1	2	3	5	8	13	21	34	55
---	---	---	---	---	----	----	----	----

A **span** gives access to a contiguous sequence of elements. The elements can be stored in many ways, including in **vectors** and built-in arrays. Like a pointer, a **span** does not own the characters it points to. In that, it resembles a **string_view** (§9.3) and an STL pair of iterators (§12.3).

Consider a common interface style:

```
void fpn(int* p, int n)
{
    for (int i = 0; i<n; ++i)
        p[i] = 0;
}
```

We assume that `p` points to `n` integers. Unfortunately, this assumption is simply a convention, so we can't use it to write a range-`for` loop and the compiler cannot implement cheap and effective range checking. Also, our assumption can be wrong:

```
void use(int x)
{
    int a[100];
    fpn(a,100);           // OK
    fpn(a,1000);        // oops, my finger slipped! (range error in fpn)
    fpn(a+10,100);      // range error in fpn
    fpn(a,x);           // suspect, but looks innocent
}
```

We can do better using a `span`:

```
void fs(span<int> p)
{
    for (int& x : p)
        x = 0;
}
```

We can use `fs` like this:

```
void use(int x)
{
    int a[100];
    fs(a);                 // implicitly creates a span<int>{a,100}
    fs(a,1000);           // error: span expected
    fs({a+10,100});       // a range error in fs
    fs({a,x});            // obviously suspect
}
```

That is, the common case, creating a `span` directly from an array, is now safe (the compiler computes the element count) and notationally simple. For other cases, the probability of mistakes is lowered because the programmer has to explicitly compose a `span`.

The common case where a `span` is passed along from function to function is simpler than for (pointer,count) interfaces and obviously doesn't require extra checking:

```
void f1(span<int> p);

void f2(span<int> p)
{
    // ...
    f1(p);
}
```

When used for subscripting (e.g., `r[i]`), range checking is done and a `gsl::fail_fast` is thrown in case of a range error. Range checks can be suppressed for performance critical code. When `span` makes it into the standard, I expect that `std::span` will use contracts [Garcia,2016] [Garcia,2018] to control responses to range violation.

Note that just a single range check is needed for the loop. Thus, for the common case where the body of a function using a `span` is a loop over the `span`, range checking is almost free.

A `span` of characters is supported directly and called `gsl::string_span`.

13.4 Specialized Containers

The standard library provides several containers that don't fit perfectly into the STL framework (Chapter 11, Chapter 12). Examples are built-in arrays, `array`, and `string`. I sometimes refer to those as “almost containers,” but that is not quite fair: they hold elements, so they are containers, but each has restrictions or added facilities that make them awkward in the context of the STL. Describing them separately also simplifies the description of the STL.

“Almost Containers”	
<code>T[N]</code>	Built-in array: a fixed-size contiguously allocated sequence of N elements of type T ; implicitly converts to a T*
<code>array<T,N></code>	A fixed-size contiguously allocated sequence of N elements of type T ; like the built-in array, but with most problems solved
<code>bitset<N></code>	A fixed-size sequence of N bits
<code>vector<bool></code>	A sequence of bits compactly stored in a specialization of <code>vector</code>
<code>pair<T,U></code>	Two elements of types T and U
<code>tuple<T...></code>	A sequence of an arbitrary number of elements of arbitrary types
<code>basic_string<C></code>	A sequence of characters of type C ; provides string operations
<code>valarray<T></code>	An array of numeric values of type T ; provides numeric operations

Why does the standard library provide so many containers? They serve common but different (often overlapping) needs. If the standard library didn't provide them, many people would have to design and implement their own. For example:

- `pair` and `tuple` are heterogeneous; all other containers are homogeneous (all elements are of the same type).
- `array`, `vector`, and `tuple` elements are contiguously allocated; `forward_list` and `map` are linked structures.
- `bitset` and `vector<bool>` hold bits and access them through proxy objects; all other standard-library containers can hold a variety of types and access elements directly.
- `basic_string` requires its elements to be some form of character and to provide string manipulation, such as concatenation and locale-sensitive operations.
- `valarray` requires its elements to be numbers and to provide numerical operations.

All of these containers can be seen as providing specialized services needed by large communities of programmers. No single container could serve all of these needs because some needs are contradictory, for example, “ability to grow” vs. “guaranteed to be allocated in a fixed location,” and “elements do not move when elements are added” vs. “contiguously allocated.”

13.4.1 array

An **array**, defined in `<array>`, is a fixed-size sequence of elements of a given type where the number of elements is specified at compile time. Thus, an **array** can be allocated with its elements on the stack, in an object, or in static storage. The elements are allocated in the scope where the **array** is defined. An **array** is best understood as a built-in array with its size firmly attached, without implicit, potentially surprising conversions to pointer types, and with a few convenience functions provided. There is no overhead (time or space) involved in using an **array** compared to using a built-in array. An **array** does *not* follow the “handle to elements” model of STL containers. Instead, an **array** directly contains its elements.

An **array** can be initialized by an initializer list:

```
array<int,3> a1 = {1,2,3};
```

The number of elements in the initializer must be equal to or less than the number of elements specified for the **array**.

The element count is not optional:

```
array<int> ax = {1,2,3};      // error size not specified
```

The element count must be a constant expression:

```
void f(int n)
{
    array<string,n> aa = {"John's", "Queens' "};    // error: size not a constant expression
    //
}
```

If you need the element count to be a variable, use **vector**.

When necessary, an **array** can be explicitly passed to a C-style function that expects a pointer. For example:

```
void f(int* p, int sz);    // C-style interface

void g()
{
    array<int,10> a;

    f(a,a.size());        // error: no conversion
    f(&a[0],a.size());    // C-style use
    f(a.data(),a.size()); // C-style use

    auto p = find(a.begin(),a.end(),777);    // C++/STL-style use
    // ...
}
```

Why would we use an **array** when **vector** is so much more flexible? An **array** is less flexible so it is simpler. Occasionally, there is a significant performance advantage to be had by directly accessing elements allocated on the stack rather than allocating elements on the free store, accessing them indirectly through the **vector** (a handle), and then deallocating them. On the other hand, the stack is a limited resource (especially on some embedded systems), and stack overflow is nasty.

For this example, it is simpler to directly use the `bitset` output operator:

```
void binary2(int i)
{
    bitset<8*sizeof(int)> b = i;    // assume 8-bit byte (see also §14.7)
    cout << b << '\n';           // write out the bits of i
}
```

13.4.3 pair and tuple

Often, we need some data that is just data; that is, a collection of values, rather than an object of a class with well-defined semantics and an invariant for its value (§3.5.2). In such cases, a simple `struct` with an appropriate set of appropriately named members is often ideal. Alternatively, we could let the standard library write the definition for us. For example, the standard-library algorithm `equal_range` returns a `pair` of iterators specifying a subsequence meeting a predicate:

```
template<typename Forward_iterator, typename T, typename Compare>
pair<Forward_iterator,Forward_iterator>
equal_range(Forward_iterator first, Forward_iterator last, const T& val, Compare cmp);
```

Given a sorted sequence [`first:last`), `equal_range()` will return the `pair` representing the subsequence that matches the predicate `cmp`. We can use that to search in a sorted sequence of `Records`:

```
auto less = [](const Record& r1, const Record& r2) { return r1.name<r2.name;};    // compare names

void f(const vector<Record>& v)           // assume that v is sorted on its "name" field
{
    auto er = equal_range(v.begin(),v.end(),Record{"Reg"},less);

    for (auto p = er.first; p!=er.second; ++p)    // print all equal records
        cout << *p;                             // assume that << is defined for Record
}
```

The first member of a `pair` is called `first` and the second member is called `second`. This naming is not particularly creative and may look a bit odd at first, but such consistent naming is a boon when we want to write generic code. Where the names `first` and `second` are too generic, we can use structured binding (§3.6.3):

```
void f2(const vector<Record>& v)         // assume that v is sorted on its "name" field
{
    auto [first,last] = equal_range(v.begin(),v.end(),Record{"Reg"},less);

    for (auto p = first; p!=last; ++p)    // print all equal records
        cout << *p;                     // assume that << is defined for Record
}
```

The standard-library `pair` (from `<utility>`) is quite frequently used in the standard library and elsewhere. A `pair` provides operators, such as `=`, `==`, and `<`, if its elements do. Type deduction makes it easy to create a `pair` without explicitly mentioning its type. For example:

```

void f(vector<string>& v)
{
    pair p1 {v.begin(),2};           // one way
    auto p2 = make_pair(v.begin(),2); // another way
    // ...
}

```

Both `p1` and `p2` are of type `pair<vector<string>::iterator,int>`.

If you need more than two elements (or less), you can use `tuple` (from `<utility>`). A `tuple` is a heterogeneous sequence of elements; for example:

```

tuple<string,int,double> t1 {"Shark",123,3.14}; // the type is explicitly specified
auto t2 = make_tuple(string{"Herring"},10,1.23); // the type is deduced to tuple<string,int,double>
tuple t3 {"Cod"s,20,9.99}; // the type is deduced to tuple<string,int,double>

```

Older code tends to use `make_tuple()` because template argument type deduction from constructor arguments is C++17.

Access to `tuple` members is through a `get` function template:

```

string s = get<0>(t1); // get the first element: "Shark"
int x = get<1>(t1); // get the second element: 123
double d = get<2>(t1); // get the third element: 3.14

```

The elements of a `tuple` are numbered (starting with zero) and the indices must be constants.

Accessing members of a `tuple` by their index is general, ugly, and somewhat error-prone. Fortunately, an element of a `tuple` with a unique type in that `tuple` can be “named” by its type:

```

auto s = get<string>(t1); // get the string: "Shark"
auto x = get<int>(t1); // get the int: 123
auto d = get<double>(t1); // get the double: 3.14

```

We can use `get<>` for writing also:

```

get<string>(t1) = "Tuna"; // write to the string
get<int>(t1) = 7; // write to the int
get<double>(t1) = 312; // write to the double

```

Like `pairs`, `tuples` can be assigned and compared if their elements can be. Like `tuple` elements, `pair` elements can be accessed using `get<>()`.

Like for `pair`, structured binding (§3.6.3) can be used for `tuple`. However, when code doesn’t need to be generic, a simple struct with named members often leads to more maintainable code.

13.5 Alternatives

The standard library offers three types to express alternatives:

- **variant** to represent one of a specified set of alternatives (in `<variant>`)
- **optional** to represent a value of a specified type or no value (in `<optional>`)
- **any** to represent one of an unbounded set of alternative types (in `<any>`)

These three types offer related functionality to the user. Unfortunately, they don’t offer a unified interface.

13.5.1 variant

A `variant<A,B,C>` is often a safer and more convenient alternative to explicitly using a `union` (§2.4). Possibly the simplest example is to return either a value or an error code:

```
variant<string,int> compose_message(istream& s)
{
    string mess;
    // ... read from s and compose message ...
    if (no_problems)
        return mess;           // return a string
    else
        return error_number;   // return an int
}
```

When you assign or initialize a `variant` with a value, it remembers the type of that value. Later, we can inquire what type the `variant` holds and extract the value. For example:

```
auto m = compose_message(cin);

if (holds_alternative<string>(m)) {
    cout << m.get<string>();
}
else {
    int err = m.get<int>();
    // ... handle error ...
}
```

This style appeals to some people who dislike exceptions (see §3.5.3), but there are more interesting uses. For example, a simple compiler may need to distinguish between different kind of nodes with different representations:

```
using Node = variant<Expression,Statement,Declaration,Type>;

void check(Node* p)
{
    if (holds_alternative<Expression>(*p)) {
        Expression& e = get<Expression>(*p);
        // ...
    }
    else if (holds_alternative<Statement>(*p)) {
        Statement& s = get<Statement>(*p);
        // ...
    }
    // ... Declaration and Type ...
}
```

This pattern of checking alternatives to decide on the appropriate action is so common and relatively inefficient that it deserves direct support:

```

void check(Node* p)
{
    visit(overloaded {
        [](Expression& e) { /* ... */ },
        [](Statement& s) { /* ... */ },
        // ... Declaration and Type ...
    }, *p);
}

```

This is basically equivalent to a virtual function call, but potentially faster. As with all claims of performance, this “potentially faster” should be verified by measurements when performance is critical. For most uses, the difference in performance is insignificant.

Unfortunately, the `overloaded` is necessary and not standard. It’s a “piece of magic” that builds an overload set from a set of arguments (usually lambdas):

```

template<class... Ts>
struct overloaded : Ts... {
    using Ts::operator()...;
};

template<class... Ts>
overloaded(Ts...) -> overloaded<Ts...>; // deduction guide

```

The “visitor” `visit` then applies `()` to the `overload`, which selects the most appropriate lambda to call according to the overload rules.

A *deduction guide* is a mechanism for resolving subtle ambiguities, primarily for constructors of class templates in foundation libraries (§6.2.3).

If we try to access a `variant` holding a different type than the expected one, `bad_variant_access` is thrown.

13.5.2 optional

An `optional<A>` can be seen as a special kind of `variant` (like a `variant<A,nothing>`) or as a generalization of the idea of an `A*` either pointing to an object or being `nullptr`.

An `optional` can be useful for functions that may or may not return an object:

```

optional<string> compose_message(istream& s)
{
    string mess;

    // ... read from s and compose message ...

    if (no_problems)
        return mess;
    return {}; // the empty optional
}

```

Given that, we can write

```

if (auto m = compose_message(cin))
    cout << *m;           // note the dereference (*)
else {
    // ... handle error ...
}

```

This appeals to some people who dislike exceptions (see §3.5.3). Note the curious use of `*`. An **optional** is treated as a pointer to its object rather than the object itself.

The **optional** equivalent to **nullptr** is the empty object, `{}`. For example:

```

int cat(optional<int> a, optional<int> b)
{
    int res = 0;
    if (a) res += *a;
    if (b) res += *b;
    return res;
}

int x = cat(17, 19);
int y = cat(17, {});
int z = cat({}, {});

```

If we try to access an **optional** that does not hold a value, the result is undefined; an exception is *not* thrown. Thus, **optional** is not guaranteed type safe.

13.5.3 any

An **any** can hold an arbitrary type and know which type (if any) it holds. It is basically an unconstrained version of **variant**:

```

any compose_message(istream& s)
{
    string mess;

    // ... read from s and compose message ...

    if (no_problems)
        return mess;           // return a string
    else
        return error_number;   // return an int
}

```

When you assign or initialize an **any** with a value, it remembers the type of that value. Later, we can inquire what type the **any** holds and extract the value. For example:

```

auto m = compose_message(cin);
string& s = any_cast<string>(m);
cout << s;

```

If we try to access an **any** holding a different type than the expected one, **bad_any_access** is thrown. There are also ways of accessing an **any** that do not rely on exceptions.

13.6 Allocators

By default, standard-library containers allocate space using `new`. Operators `new` and `delete` provide a general free store (also called dynamic memory or heap) that can hold objects of arbitrary size and user-controlled lifetime. This implies time and space overheads that can be eliminated in many special cases. Therefore, the standard-library containers offer the opportunity to install allocators with specific semantics where needed. This has been used to address a wide variety of concerns related to performance (e.g., pool allocators), security (allocators that clean-up memory as part of deletion), per-thread allocation, and non-uniform memory architectures (allocating in specific memories with pointer types to match). This is not the place to discuss these important, but very specialized and often advanced techniques. However, I will give one example motivated by a real-world problem for which a pool allocator was the solution.

An important, long-running system used an event queue (see §15.6) using `vectors` as events that were passed as `shared_ptrs`. That way, the last user of an event implicitly deleted it:

```
struct Event {
    vector<int> data = vector<int>(512);
};

list<shared_ptr<Event>> q;

void producer()
{
    for (int n = 0; n!=LOTS; ++n) {
        lock_guard lk {m}; // m is a mutex (§15.5)
        q.push_back(make_shared<Event>());
        cv.notify_one();
    }
}
```

From a logical point of view this worked nicely. It is logically simple, so the code is robust and maintainable. Unfortunately, this led to massive fragmentation. After 100,000 events had been passed among 16 producers and 4 consumers, more than 6GB memory had been consumed.

The traditional solution to fragmentation problems is to rewrite the code to use a pool allocator. A pool allocator is an allocator that manages objects of a single fixed size and allocates space for many objects at a time, rather than using individual allocations. Fortunately, C++17 offers direct support for that. The pool allocator is defined in the `pmr` (“polymorphic memory resource”) sub-namespace of `std`:

```
pmr::synchronized_pool_resource pool; // make a pool

struct Event {
    vector<int> data = vector<int>{512,&pool}; // let Events use the pool
};

list<shared_ptr<Event>> q {&pool}; // let q use the pool
```

```

void producer()
{
    for (int n = 0; n!=LOTS; ++n) {
        scoped_lock lk {m};    // m is a mutex (§15.5)
        q.push_back(allocate_shared<Event,pmr::polymorphic_allocator<Event>>(&pool));
        cv.notify_one();
    }
}

```

Now, after 100,000 events had been passed among 16 producers and 4 consumers, less than 3MB memory had been consumed. That’s about a 2000-fold improvement! Naturally, the amount of memory actually in use (as opposed to memory wasted to fragmentation) is unchanged. After eliminating fragmentation, memory use was stable over time so the system could run for months.

Techniques like this have been applied with good effects from the earliest days of C++, but generally they required code to be rewritten to use specialized containers. Now, the standard containers optionally take allocator arguments. The default is for the containers to use **new** and **delete**.

13.7 Time

In **<chrono>**, the standard library provides facilities for dealing with time. For example, here is the basic way of timing something:

```

using namespace std::chrono;    // in sub-namespace std::chrono; see §3.4

auto t0 = high_resolution_clock::now();
do_work();
auto t1 = high_resolution_clock::now();
cout << duration_cast<milliseconds>(t1-t0).count() << "msec\n";

```

The clock returns a **time_point** (a point in time). Subtracting two **time_points** gives a **duration** (a period of time). Various clocks give their results in various units of time (the clock I used measures **nanoseconds**), so it is usually a good idea to convert a **duration** into a known unit. That’s what **duration_cast** does.

Don’t make statements about “efficiency” of code without first doing time measurements. Guesses about performance are most unreliable.

To simplify notation and minimize errors, **<chrono>** offers time-unit suffixes (§5.4.4). For example:

```

this_thread::sleep(10ms+33us);    // wait for 10 milliseconds and 33 microseconds

```

The chrono suffixes are defined in namespace **std::chrono_literals**.

An elegant and efficient extension to **<chrono>**, supporting longer time intervals (e.g., years and months), calendars, and time zones, is being added to the standard for C++20. It is currently available and in wide production use [Hinnant,2018] [Hinnant,2018b]. You can say things like

```

auto spring_day = apr/7/2018;
cout << weekday(spring_day) << "\n";    // Saturday

```

It even handles leap seconds.

13.8 Function Adaption

When passing a function as a function argument, the type of the argument must exactly match the expectations expressed in the called function's declaration. If the intended argument “almost matches expectations,” we have three good alternatives:

- Use a lambda (§13.8.1).
- Use `std::mem_fn()` to make a function object from a member function (§13.8.2).
- Define the function to accept a `std::function` (§13.8.3).

There are many other ways, but usually one of these three ways works best.

13.8.1 Lambdas as Adaptors

Consider the classical “draw all shapes” example:

```
void draw_all(vector<Shape*>& v)
{
    for_each(v.begin(),v.end(),[](Shape* p) { p->draw(); });
}
```

Like all standard-library algorithms, `for_each()` calls its argument using the traditional function call syntax `f(x)`, but `Shape's draw()` uses the conventional OO notation `x->f()`. A lambda easily mediates between the two notations.

13.8.2 mem_fn()

Given a member function, the function adaptor `mem_fn(mf)` produces a function object that can be called as a nonmember function. For example:

```
void draw_all(vector<Shape*>& v)
{
    for_each(v.begin(),v.end(),mem_fn(&Shape::draw));
}
```

Before the introduction of lambdas in C++11, `mem_fn()` and equivalents were the main way to map from the object-oriented calling style to the functional one.

13.8.3 function

The standard-library `function` is a type that can hold any object you can invoke using the call operator `()`. That is, an object of type `function` is a function object (§6.3.2). For example:

```
int f1(double);
function<int(double)> fct1 {f1};           // initialize to f1

int f2(string);
function fct2 {f2};                     // fct2's type is function<int(string)>

function fct3 = [](Shape* p) { p->draw(); }; // fct3's type is function<void(Shape*)>
```

For `fct2`, I let the type of the `function` be deduced from the initializer: `int(string)`.

Obviously, **functions** are useful for callbacks, for passing operations as arguments, for passing function objects, etc. However, it may introduce some run-time overhead compared to direct calls, and a **function**, being an object, does not participate in overloading. If you need to overload function objects (including lambdas), consider **overloaded** (§13.5.1).

13.9 Type Functions

A *type function* is a function that is evaluated at compile time given a type as its argument or returning a type. The standard library provides a variety of type functions to help library implementers (and programmers in general) to write code that takes advantage of aspects of the language, the standard library, and code in general.

For numerical types, **numeric_limits** from `<limits>` presents a variety of useful information (§14.7). For example:

```
constexpr float min = numeric_limits<float>::min();    // smallest positive float
```

Similarly, object sizes can be found by the built-in **sizeof** operator (§1.4). For example:

```
constexpr int sz = sizeof(int);    // the number of bytes in an int
```

Such type functions are part of C++'s mechanisms for compile-time computation that allow tighter type checking and better performance than would otherwise have been possible. Use of such features is often called *metaprogramming* or (when templates are involved) *template metaprogramming*. Here, I just present the use of two facilities provided by the standard library: **iterator_traits** (§13.9.1) and type predicates (§13.9.2). Concepts (§7.2) make some of these techniques redundant and simplify many of the rest, but concepts are still not standard or universally available, so the techniques presented here are in wide use.

13.9.1 iterator_traits

The standard-library **sort()** takes a pair of iterators supposed to define a sequence (Chapter 12). Furthermore, those iterators must offer random access to that sequence, that is, they must be *random-access iterators*. Some containers, such as **forward_list**, do not offer that. In particular, a **forward_list** is a singly-linked list so subscripting would be expensive and there is no reasonable way to refer back to a previous element. However, like most containers, **forward_list** offers *forward iterators* that can be used to traverse the sequence by algorithms and **for**-statements (§6.2).

The standard library provides a mechanism, **iterator_traits**, that allows us to check which kind of iterator is provided. Given that, we can improve the range **sort()** from §12.8 to accept either a **vector** or a **forward_list**. For example:

```
void test(vector<string>& v, forward_list<int>& lst)
{
    sort(v);    // sort the vector
    sort(lst);  // sort the singly-linked list
}
```

The techniques needed to make that work are generally useful.

First, I write two helper functions that take an extra argument indicating whether they are to be used for random-access iterators or forward iterators. The version taking random-access iterator arguments is trivial:

```
template<typename Ran>                                // for random-access iterators
void sort_helper(Ran beg, Ran end, random_access_iterator_tag) // we can subscript into [beg:end]
{
    sort(beg,end);    // just sort it
}
```

The version for forward iterators simply copies the list into a **vector**, sorts, and copies back:

```
template<typename For>                                // for forward iterators
void sort_helper(For beg, For end, forward_iterator_tag) // we can traverse [beg:end]
{
    vector<Value_type<For>> v {beg,end}; // initialize a vector from [beg:end]
    sort(v.begin(),v.end());           // use the random access sort
    copy(v.begin(),v.end(),beg);       // copy the elements back
}
```

Value_type<For> is the type of **For**'s elements, called it's *value type*. Every standard-library iterator has a member **value_type**. I get the **Value_type<For>** notation by defining a type alias (§6.4.2):

```
template<typename C>
using Value_type = typename C::value_type; // C's value type
```

Thus, for a **vector<X>**, **Value_type<X>** is **X**.

The real “type magic” is in the selection of helper functions:

```
template<typename C>
void sort(C& c)
{
    using Iter = Iterator_type<C>;
    sort_helper(c.begin(),c.end(),Iterator_category<Iter>{});
}
```

Here, I use two type functions: **Iterator_type<C>** returns the iterator type of **C** (that is, **C::iterator**) and then **Iterator_category<Iter>{}** constructs a “tag” value indicating the kind of iterator provided:

- **std::random_access_iterator_tag** if **C**'s iterator supports random access
- **std::forward_iterator_tag** if **C**'s iterator supports forward iteration

Given that, we can select between the two sorting algorithms at compile time. This technique, called *tag dispatch*, is one of several used in the standard library and elsewhere to improve flexibility and performance.

We could define **Iterator_type** like this:

```
template<typename C>
using Iterator_type = typename C::iterator; // C's iterator type
```

However, to extend this idea to types without member types, such as pointers, the standard-library support for tag dispatch comes in the form of a class template **iterator_traits** from **<iterator>**. The specialization for pointers looks like this:

```

template<class T>
struct iterator_traits<T*> {
    using difference_type = ptrdiff_t;
    using value_type = T;
    using pointer = T*;
    using reference = T&;
    using iterator_category = random_access_iterator_tag;
};

```

We can now write:

```

template<typename Iter>
    using iterator_category = typename std::iterator_traits<Iter>::iterator_category; // Iter's category

```

Now an `int*` can be used as a random-access iterator despite not having a member type; `iterator_category<int*>` is `random_access_iterator_tag`.

Many traits and traits-based techniques will be made redundant by concepts (§7.2). Consider the concepts version of the `sort()` example:

```

template<RandomAccessIterator Iter>
void sort(Iter p, Iter q); // use for std::vector and other types supporting random access

template<ForwardIterator Iter>
void sort(Iter p, Iter q)
    // use for std::list and other types supporting just forward traversal
{
    vector<Value_type<Iter>> v {p,q};
    sort(v); // use the random-access sort
    copy(v.begin(),v.end(),p);
}

template<Range R>
void sort(R& r)
{
    sort(r.begin(),r.end()); // use the appropriate sort
}

```

Progress happens.

13.9.2 Type Predicates

In `<type_traits>`, the standard library offers simple type functions, called *type predicates* that answers a fundamental question about types. For example:

```

bool b1 = std::is_arithmetic<int>(); // yes, int is an arithmetic type
bool b2 = std::is_arithmetic<string>(); // no, std::string is not an arithmetic type

```

Other examples are `is_class`, `is_pod`, `is_literal_type`, `has_virtual_destructor`, and `is_base_of`. They are most useful when we write templates. For example:

```

template<typename Scalar>
class complex {
    Scalar re, im;
public:
    static_assert(is_arithmetic<Scalar>(), "Sorry, I only support complex of arithmetic types");
    // ...
};

```

To improve readability, the standard library defines template aliases. For example:

```

template<typename T>
constexpr bool is_arithmetic_v = std::is_arithmetic<T>();

```

I'm no great fan of the `_v` suffix notation, but the technique for defining aliases is immensely useful. For example, the standard library defines the concept **Regular** (§12.7) like this:

```

template<class T>
concept Regular = Semiregular<T> && EqualityComparable<T>;

```

13.9.3 `enable_if`

Obvious ways of using type predicates includes conditions for **static_asserts**, compile-time **ifs**, and **enable_ifs**. The standard-library **enable_if** is a widely used mechanism for conditionally introducing definitions. Consider defining a “smart pointer”:

```

template<typename T>
class Smart_pointer {
    // ...
    T& operator*();
    T& operator->();    // -> should work if and only if T is a class
};

```

The `->` should be defined if and only if **T** is a class type. For example, **Smart_pointer<vector<T>>** should have `->`, but **Smart_pointer<int>** should not.

We cannot use a compile-time **if** because we are not inside a function. Instead, we write

```

template<typename T>
class Smart_pointer {
    // ...
    T& operator*();
    std::enable_if<is_class<T>(),T&> operator->();    // -> is defined if and only if T is a class
};

```

If **is_class<T>()** is **true**, the return type of **operator->()** is **T&**; otherwise, the definition of **operator->()** is ignored.

The syntax of **enable_if** is odd, awkward to use, and will in many cases be rendered redundant by concepts (§7.2). However, **enable_if** is the basis for much current template metaprogramming and for many standard-library components. It relies on a subtle language feature called SFINAE (“Substitution Failure Is Not An Error”).

13.10 Advice

- [1] A library doesn't have to be large or complicated to be useful; §13.1.
- [2] A resource is anything that has to be acquired and (explicitly or implicitly) released; §13.2.
- [3] Use resource handles to manage resources (RAII); §13.2; [CG: R.1].
- [4] Use `unique_ptr` to refer to objects of polymorphic type; §13.2.1; [CG: R.20].
- [5] Use `shared_ptr` to refer to shared objects (only); §13.2.1; [CG: R.20].
- [6] Prefer resource handles with specific semantics to smart pointers; §13.2.1.
- [7] Prefer `unique_ptr` to `shared_ptr`; §5.3, §13.2.1.
- [8] Use `make_unique()` to construct `unique_ptrs`; §13.2.1; [CG: R.22].
- [9] Use `make_shared()` to construct `shared_ptrs`; §13.2.1; [CG: R.23].
- [10] Prefer smart pointers to garbage collection; §5.3, §13.2.1.
- [11] Don't use `std::move()`; §13.2.2; [CG: ES.56].
- [12] Use `std::forward()` exclusively for forwarding; §13.2.2.
- [13] Never read from an object after `std::move()`ing or `std::forward()`ing it; §13.2.2.
- [14] Prefer `spans` to pointer-plus-count interfaces; §13.3; [CG: F.24].
- [15] Use `array` where you need a sequence with a `constexpr` size; §13.4.1.
- [16] Prefer `array` over built-in arrays; §13.4.1; [CG: SL.con.2].
- [17] Use `bitset` if you need `N` bits and `N` is not necessarily the number of bits in a built-in integer type; §13.4.2.
- [18] Don't overuse `pair` and `tuple`; named `structs` often lead to more readable code; §13.4.3.
- [19] When using `pair`, use template argument deduction or `make_pair()` to avoid redundant type specification; §13.4.3.
- [20] When using `tuple`, use template argument deduction and `make_tuple()` to avoid redundant type specification; §13.4.3; [CG: T.44].
- [21] Prefer `variant` to explicit use of `unions`; §13.5.1; [CG: C.181].
- [22] Use allocators to prevent memory fragmentation; §13.6.
- [23] Time your programs before making claims about efficiency; §13.7.
- [24] Use `duration_cast` to report time measurements with proper units; §13.7.
- [25] When specifying a `duration`, use proper units; §13.7.
- [26] Use `mem_fn()` or a lambda to create function objects that can invoke a member function when called using the traditional function call notation; §13.8.2.
- [27] Use `function` when you need to store something that can be called; §13.8.3.
- [28] You can write code to explicitly depend on properties of types; §13.9.
- [29] Prefer concepts over traits and `enable_if` whenever you can; §13.9.
- [30] Use aliases and type predicates to simplify notation; §13.9.1, §13.9.2.

This page intentionally left blank

Numerics

The purpose of computing is insight, not numbers.
– R. W. Hamming

*... but for the student,
numbers are often the best road to insight.*
– A. Ralston

- Introduction
- Mathematical Functions
- Numerical Algorithms
 - Parallel Numerical Algorithms
- Complex Numbers
- Random Numbers
- Vector Arithmetic
- Numeric Limits
- Advice

14.1 Introduction

C++ was not designed primarily with numeric computation in mind. However, numeric computation typically occurs in the context of other work – such as database access, networking, instrument control, graphics, simulation, and financial analysis – so C++ becomes an attractive vehicle for computations that are part of a larger system. Furthermore, numeric methods have come a long way from being simple loops over vectors of floating-point numbers. Where more complex data structures are needed as part of a computation, C++'s strengths become relevant. The net effect is that C++ is widely used for scientific, engineering, financial, and other computation involving sophisticated numerics. Consequently, facilities and techniques supporting such computation have emerged. This chapter describes the parts of the standard library that support numerics.

14.2 Mathematical Functions

In `<cmath>`, we find the *standard mathematical functions*, such as `sqrt()`, `log()`, and `sin()` for arguments of type `float`, `double`, and `long double`:

Standard Mathematical Functions	
<code>abs(x)</code>	Absolute value
<code>ceil(x)</code>	Smallest integer $\geq x$
<code>floor(x)</code>	Largest integer $\leq x$
<code>sqrt(x)</code>	Square root; x must be non-negative
<code>cos(x)</code>	Cosine
<code>sin(x)</code>	Sine
<code>tan(x)</code>	Tangent
<code>acos(x)</code>	Arccosine; the result is non-negative
<code>asin(x)</code>	Arcsine; the result nearest to 0 is returned
<code>atan(x)</code>	Arctangent
<code>sinh(x)</code>	Hyperbolic sine
<code>cosh(x)</code>	Hyperbolic cosine
<code>tanh(x)</code>	Hyperbolic tangent
<code>exp(x)</code>	Base e exponential
<code>log(x)</code>	Natural logarithm, base e; x must be positive
<code>log10(x)</code>	Base 10 logarithm

The versions for `complex` (§14.4) are found in `<complex>`. For each function, the return type is the same as the argument type.

Errors are reported by setting `errno` from `<cerrno>` to `EDOM` for a domain error and to `ERANGE` for a range error. For example:

```
void f()
{
    errno = 0; // clear old error state
    sqrt(-1);
    if (errno==EDOM)
        cerr << "sqrt() not defined for negative argument";

    errno = 0; // clear old error state
    pow(numeric_limits<double>::max(),2);
    if (errno == ERANGE)
        cerr << "result of pow() too large to represent as a double";
}
```

A few more mathematical functions are found in `<cstdliblib>` and the so-called *special mathematical functions*, such as `beta()`, `rieman_zeta()`, and `sph_bessel()`, are also in `<cmath>`.

14.3 Numerical Algorithms

In `<numeric>`, we find a small set of generalized numerical algorithms, such as `accumulate()`.

Numerical Algorithms	
<code>x=accumulate(b,e,i)</code>	<code>x</code> is the sum of <code>i</code> and the elements of <code>[b:e)</code>
<code>x=accumulate(b,e,i,f)</code>	<code>accumulate</code> using <code>f</code> instead of <code>+</code>
<code>x=inner_product(b,e,b2,i)</code>	<code>x</code> is the inner product of <code>[b:e)</code> and <code>[b2:b2+(e-b))</code> , that is, the sum of <code>i</code> and <code>(*p1)*(*p2)</code> for each <code>p1</code> in <code>[b:e)</code> and the corresponding <code>p2</code> in <code>[b2:b2+(e-b))</code>
<code>x=inner_product(b,e,b2,i,f,f2)</code>	<code>inner_product</code> using <code>f</code> and <code>f2</code> instead of <code>+</code> and <code>*</code>
<code>p=partial_sum(b,e,out)</code>	Element <code>i</code> of <code>[out:p)</code> is the sum of elements <code>[b:b+i)</code>
<code>p=partial_sum(b,e,out,f)</code>	<code>partial_sum</code> using <code>f</code> instead of <code>+</code>
<code>p=adjacent_difference(b,e,out)</code>	Element <code>i</code> of <code>[out:p)</code> is <code>*(b+i)-*(b+i-1)</code> for <code>i>0</code> ; if <code>e-b>0</code> , then <code>*out</code> is <code>*b</code>
<code>p=adjacent_difference(b,e,out,f)</code>	<code>adjacent_difference</code> using <code>f</code> instead of <code>-</code>
<code>iota(b,e,v)</code>	For each element in <code>[b:e)</code> assign <code>++v</code> ; thus the sequence becomes <code>v+1, v+2, ...</code>
<code>x=gcd(n,m)</code>	<code>x</code> is the greatest common denominator of integers <code>n</code> and <code>m</code>
<code>x=lcm(n,m)</code>	<code>x</code> is the least common multiple of integers <code>n</code> and <code>m</code>

These algorithms generalize common operations such as computing a sum by letting them apply to all kinds of sequences. They also make the operation applied to elements of those sequences a parameter. For each algorithm, the general version is supplemented by a version applying the most common operator for that algorithm. For example:

```
list<double> lst {1, 2, 3, 4, 5, 9999.99999};
auto s = accumulate(lst.begin(),lst.end(),0.0); // calculate the sum: 10014.9999
```

These algorithms work for every standard-library sequence and can have operations supplied as arguments (§14.3).

14.3.1 Parallel Algorithms

In `<numeric>`, the numerical algorithms have parallel versions (§12.9) that are slightly different:

Parallel Numerical Algorithms	
<code>x=reduce(b,e,v)</code>	<code>x=accumulate(b,e,v)</code> , except out of order
<code>x=reduce(b,e)</code>	<code>x=reduce(b,e,V{})</code> , where <code>V</code> is <code>b</code> 's value type
<code>x=reduce(pol,b,e,v)</code>	<code>x=reduce(b,e,v)</code> with execution policy <code>pol</code>
<code>x=reduce(pol,b,e)</code>	<code>x=reduce(pol,b,e,V{})</code> , where <code>V</code> is <code>b</code> 's value type
<code>p=exclusive_scan(pol,b,e,out)</code>	<code>p=partial_sum(b,e,out)</code> according to <code>pol</code> , excludes the <code>i</code> th input element from the <code>i</code> th sum
<code>p=inclusive_scan(pol,b,e,out)</code>	<code>p=partial_sum(b,e,out)</code> according to <code>pol</code> includes the <code>i</code> th input element in the <code>i</code> th sum

Parallel Numerical Algorithms (continued)	
<code>p=transform_reduce(pol,b,e,f,v)</code>	<code>f(x)</code> for each <code>x</code> in <code>[b:e)</code> , then <code>reduce</code>
<code>p=transform_exclusive_scan(pol,b,e,out,f,v)</code>	<code>f(x)</code> for each <code>x</code> in <code>[b:e)</code> , then <code>exclusive_scan</code>
<code>p=transform_inclusive_scan(pol,b,e,out,f,v)</code>	<code>f(x)</code> for each <code>x</code> in <code>[b:e)</code> , then <code>inclusive_scan</code>

For simplicity, I left out the versions of these algorithms that take functor arguments, rather than just using `+` and `=`. Except for `reduce()`, I also left out the versions with default policy (sequential) and default value.

Just as for the parallel algorithms in `<algorithm>` (§12.9), we can specify an execution policy:

```
vector<double> v {1, 2, 3, 4, 5, 9999.99999};
auto s = reduce(v.begin(),v.end());           // calculate the sum using a double as the accumulator

vector<double> large;
// ... fill large with lots of values ...
auto s2 = reduce(par_unseq,large.begin(),large.end()); // calculate the sum using available parallelism
```

The parallel algorithms (e.g., `reduce()`) differ from the sequential ones (e.g., `accumulate()`) by allowing operations on elements in unspecified order.

14.4 Complex Numbers

The standard library supports a family of complex number types along the lines of the `complex` class described in §4.2.1. To support complex numbers where the scalars are single-precision floating-point numbers (`floats`), double-precision floating-point numbers (`doubles`), etc., the standard library `complex` is a template:

```
template<typename Scalar>
class complex {
public:
    complex(const Scalar& re = {}, const Scalar& im = {}); // default function arguments; see §3.6.1
    // ...
};
```

The usual arithmetic operations and the most common mathematical functions are supported for complex numbers. For example:

```
void f(complex<float> fl, complex<double> db)
{
    complex<long double> ld {fl+sqrt(db)};
    db += fl*3;
    fl = pow(1/fl,2);
    // ...
}
```

The `sqrt()` and `pow()` (exponentiation) functions are among the usual mathematical functions defined in `<complex>` (§14.2).

14.5 Random Numbers

Random numbers are useful in many contexts, such as testing, games, simulation, and security. The diversity of application areas is reflected in the wide selection of random number generators provided by the standard library in `<random>`. A random number generator consists of two parts:

- [1] An *engine* that produces a sequence of random or pseudo-random values
- [2] A *distribution* that maps those values into a mathematical distribution in a range

Examples of distributions are `uniform_int_distribution` (where all integers produced are equally likely), `normal_distribution` (“the bell curve”), and `exponential_distribution` (exponential growth); each for some specified range. For example:

```
using my_engine = default_random_engine;           // type of engine
using my_distribution = uniform_int_distribution<>; // type of distribution

my_engine re {};                                  // the default engine
my_distribution one_to_six {1,6};                 // distribution that maps to the ints 1..6
auto die = [](){ return one_to_six(re); }         // make a generator

int x = die();                                    // roll the die: x becomes a value in [1:6]
```

Thanks to its uncompromising attention to generality and performance, one expert has deemed the standard-library random number component “what every random number library wants to be when it grows up.” However, it can hardly be deemed “novice friendly.” The `using` statements and the lambda make what is being done a bit more obvious.

For novices (of any background) the fully general interface to the random number library can be a serious obstacle. A simple uniform random number generator is often sufficient to get started. For example:

```
Rand_int rnd {1,10};           // make a random number generator for [1:10]
int x = rnd();                 // x is a number in [1:10]
```

So, how could we get that? We have to get something that, like `die()`, combines an engine with a distribution inside a class `Rand_int`:

```
class Rand_int {
public:
    Rand_int(int low, int high) :dist{low,high} { }
    int operator()() { return dist(re); }           // draw an int
    void seed(int s) { re.seed(s); }               // choose new random engine seed
private:
    default_random_engine re;
    uniform_int_distribution<> dist;
};
```

That definition is still “expert level,” but the *use* of `Rand_int()` is manageable in the first week of a C++ course for novices. For example:

```

int main()
{
    constexpr int max = 9;
    Rand_int rnd {0,max};           // make a uniform random number generator

    vector<int> histogram(max+1);   // make a vector of appropriate size
    for (int i=0; i!=200; ++i)
        ++histogram[rnd()];       // fill histogram with the frequencies of numbers [0:max]

    for (int i = 0; i!=histogram.size(); ++i) { // write out a bar graph
        cout << i << '\t';
        for (int j=0; j!=histogram[i]; ++j) cout << '!';
        cout << endl;
    }
}

```

The output is a (reassuringly boring) uniform distribution (with reasonable statistical variation):

```

0 *****
1 *****
2 *****
3 *****
4 *****
5 *****
6 *****
7 *****
8 *****
9 *****

```

There is no standard graphics library for C++, so I use “ASCII graphics.” Obviously, there are lots of open source and commercial graphics and GUI libraries for C++, but in this book I restrict myself to ISO standard facilities.

14.6 Vector Arithmetic

The **vector** described in §11.2 was designed to be a general mechanism for holding values, to be flexible, and to fit into the architecture of containers, iterators, and algorithms. However, it does not support mathematical vector operations. Adding such operations to **vector** would be easy, but its generality and flexibility preclude optimizations that are often considered essential for serious numerical work. Consequently, the standard library provides (in `<valarray>`) a **vector**-like template, called **valarray**, that is less general and more amenable to optimization for numerical computation:

```

template<typename T>
class valarray {
    // ...
};

```

The usual arithmetic operations and the most common mathematical functions are supported for **valarrays**. For example:

```

void f(valarray<double>& a1, valarray<double>& a2)
{
    valarray<double> a = a1*3.14+a2/a1;           // numeric array operators *, +, /, and =
    a2 += a1*3.14;
    a = abs(a);
    double d = a2[7];
    // ...
}

```

In addition to arithmetic operations, `valarray` offers stride access to help implement multidimensional computations.

14.7 Numeric Limits

In `<limits>`, the standard library provides classes that describe the properties of built-in types – such as the maximum exponent of a `float` or the number of bytes in an `int`. For example, we can assert that a `char` is signed:

```

static_assert(numeric_limits<char>::is_signed,"unsigned characters!");
static_assert(100000<numeric_limits<int>::max(),"small ints!");

```

Note that the second assert (only) works because `numeric_limits<int>::max()` is a `constexpr` function (§1.6).

14.8 Advice

- [1] Numerical problems are often subtle. If you are not 100% certain about the mathematical aspects of a numerical problem, either take expert advice, experiment, or do both; §14.1.
- [2] Don't try to do serious numeric computation using only the bare language; use libraries; §14.1.
- [3] Consider `accumulate()`, `inner_product()`, `partial_sum()`, and `adjacent_difference()` before you write a loop to compute a value from a sequence; §14.3.
- [4] Use `std::complex` for complex arithmetic; §14.4.
- [5] Bind an engine to a distribution to get a random number generator; §14.5.
- [6] Be careful that your random numbers are sufficiently random; §14.5.
- [7] Don't use the C standard-library `rand()`; it isn't insufficiently random for real uses; §14.5.
- [8] Use `valarray` for numeric computation when run-time efficiency is more important than flexibility with respect to operations and element types; §14.6.
- [9] Properties of numeric types are accessible through `numeric_limits`; §14.7.
- [10] Use `numeric_limits` to check that the numeric types are adequate for their use; §14.7.

This page intentionally left blank

Concurrency

*Keep it simple:
as simple as possible,
but no simpler.
– A. Einstein*

- Introduction
- Tasks and **threads**
- Passing Arguments
- Returning Results
- Sharing Data
- Waiting for Events
- Communicating Tasks
 - **future** and **promise**; **packaged_task**; **async()**
- Advice

15.1 Introduction

Concurrency – the execution of several tasks simultaneously – is widely used to improve throughput (by using several processors for a single computation) or to improve responsiveness (by allowing one part of a program to progress while another is waiting for a response). All modern programming languages provide support for this. The support provided by the C++ standard library is a portable and type-safe variant of what has been used in C++ for more than 20 years and is almost universally supported by modern hardware. The standard-library support is primarily aimed at supporting systems-level concurrency rather than directly providing sophisticated higher-level concurrency models; those can be supplied as libraries built using the standard-library facilities.

The standard library directly supports concurrent execution of multiple threads in a single address space. To allow that, C++ provides a suitable memory model and a set of atomic operations. The atomic operations allow lock-free programming [Dechev,2010]. The memory model

ensures that as long as a programmer avoids data races (uncontrolled concurrent access to mutable data), everything works as one would naively expect. However, most users will see concurrency only in terms of the standard library and libraries built on top of that. This section briefly gives examples of the main standard-library concurrency support facilities: `threads`, `mutexes`, `lock()` operations, `packaged_tasks`, and `utures`. These features are built directly upon what operating systems offer and do not incur performance penalties compared with those. Neither do they guarantee significant performance improvements compared to what the operating system offers.

Do not consider concurrency a panacea. If a task can be done sequentially, it is often simpler and faster to do so.

As an alternative to using explicit concurrency features, we can often use a parallel algorithm to exploit multiple execution engines for better performance (§12.9, §14.3.1).

15.2 Tasks and threads

We call a computation that can potentially be executed concurrently with other computations a *task*. A *thread* is the system-level representation of a task in a program. A task to be executed concurrently with other tasks is launched by constructing a `std::thread` (found in `<thread>`) with the task as its argument. A task is a function or a function object:

```
void f();           // function

struct F {         // function object
    void operator(); // F's call operator (§6.3.2)
};

void user()
{
    thread t1 {f}; // f() executes in separate thread
    thread t2 {F()}; // F() executes in separate thread

    t1.join();    // wait for t1
    t2.join();    // wait for t2
}
```

The `join()`s ensure that we don't exit `user()` until the threads have completed. To “join” a `thread` means to “wait for the thread to terminate.”

Threads of a program share a single address space. In this, threads differ from processes, which generally do not directly share data. Since threads share an address space, they can communicate through shared objects (§15.5). Such communication is typically controlled by locks or other mechanisms to prevent data races (uncontrolled concurrent access to a variable).

Programming concurrent tasks can be *very* tricky. Consider possible implementations of the tasks `f` (a function) and `F` (a function object):

```
void f()
{
    cout << "Hello ";
}
```

```
struct F {
    void operator() { cout << "Parallel World!\n"; }
};
```

This is an example of a bad error: here, `f` and `F()` each use the object `cout` without any form of synchronization. The resulting output would be unpredictable and could vary between different executions of the program because the order of execution of the individual operations in the two tasks is not defined. The program may produce “odd” output, such as

```
PaHerallllel o World!
```

Only a specific guarantee in the standard saves us from a data race within the definition of `ostream` that could lead to a crash.

When defining tasks of a concurrent program, our aim is to keep tasks completely separate except where they communicate in simple and obvious ways. The simplest way of thinking of a concurrent task is as a function that happens to run concurrently with its caller. For that to work, we just have to pass arguments, get a result back, and make sure that there is no use of shared data in between (no data races).

15.3 Passing Arguments

Typically, a task needs data to work upon. We can easily pass data (or pointers or references to the data) as arguments. Consider:

```
void f(vector<double>& v);    // function: do something with v

struct F {                  // function object: do something with v
    vector<double>& v;
    F(vector<double>& vv) :v{vv} { }
    void operator();        // application operator; §6.3.2
};

int main()
{
    vector<double> some_vec {1,2,3,4,5,6,7,8,9};
    vector<double> vec2 {10,11,12,13,14};

    thread t1 {f,ref(some_vec)};    // f(some_vec) executes in a separate thread
    thread t2 {F{vec2}};           // F(vec2)() executes in a separate thread

    t1.join();
    t2.join();
}
```

Obviously, `F{vec2}` saves a reference to the argument vector in `F`. `F` can now use that vector and hopefully no other task accesses `vec2` while `F` is executing. Passing `vec2` by value would eliminate that risk.

The initialization with `{f,ref(some_vec)}` uses a `thread` variadic template constructor that can accept an arbitrary sequence of arguments (§7.4). The `ref()` is a type function from `<functional>` that

unfortunately is needed to tell the variadic template to treat `some_vec` as a reference, rather than as an object. Without that `ref()`, `some_vec` would be passed by value. The compiler checks that the first argument can be invoked given the following arguments and builds the necessary function object to pass to the thread. Thus, if `F::operator()` and `f()` perform the same algorithm, the handling of the two tasks are roughly equivalent: in both cases, a function object is constructed for the `thread` to execute.

15.4 Returning Results

In the example in §15.3, I pass the arguments by non-`const` reference. I only do that if I expect the task to modify the value of the data referred to (§1.7). That's a somewhat sneaky, but not uncommon, way of returning a result. A less obscure technique is to pass the input data by `const` reference and to pass the location of a place to deposit the result as a separate argument:

```
void f(const vector<double>& v, double* res);    // take input from v; place result in *res

class F {
public:
    F(const vector<double>& vv, double* p) :v{vv}, res{p} {}
    void operator()();                        // place result in *res
private:
    const vector<double>& v;                   // source of input
    double* res;                             // target for output
};

double g(const vector<double>&); // use return value

void user(vector<double>& vec1, vector<double> vec2, vector<double> vec3)
{
    double res1;
    double res2;
    double res3;

    thread t1 {f, cref(vec1), &res1};        // f(vec1, &res1) executes in a separate thread
    thread t2 {F{vec2, &res2}};             // F{vec2, &res2}() executes in a separate thread
    thread t3 { [&](){ res3 = g(vec3); } }; // capture local variables by reference

    t1.join();
    t2.join();
    t3.join();

    cout << res1 << ' ' << res2 << ' ' << res3 << '\n';
}
```

This works and the technique is very common, but I don't consider returning results through references particularly elegant, so I return to this topic in §15.7.1.

15.5 Sharing Data

Sometimes tasks need to share data. In that case, the access has to be synchronized so that at most one task at a time has access. Experienced programmers will recognize this as a simplification (e.g., there is no problem with many tasks simultaneously reading immutable data), but consider how to ensure that at most one task at a time has access to a given set of objects.

The fundamental element of the solution is a **mutex**, a “mutual exclusion object.” A **thread** acquires a **mutex** using a **lock()** operation:

```
mutex m; // controlling mutex
int sh;  // shared data

void f()
{
    scoped_lock lck {m};           // acquire mutex
    sh += 7;                       // manipulate shared data
} // release mutex implicitly
```

The type of **lck** is deduced to be **scoped_lock<mutex>** (§6.2.3). The **scoped_lock**’s constructor acquires the mutex (through a call **m.lock()**). If another thread has already acquired the mutex, the thread waits (“blocks”) until the other thread completes its access. Once a thread has completed its access to the shared data, the **scoped_lock** releases the **mutex** (with a call **m.unlock()**). When a **mutex** is released, **threads** waiting for it resume executing (“are woken up”). The mutual exclusion and locking facilities are found in **<mutex>**.

Note the use of RAII (§5.3). Use of resource handles, such as **scoped_lock** and **unique_lock** (§15.6), is simpler and far safer than explicitly locking and unlocking **mutexes**.

The correspondence between the shared data and a **mutex** is conventional: the programmer simply has to know which **mutex** is supposed to correspond to which data. Obviously, this is error-prone, and equally obviously we try to make the correspondence clear through various language means. For example:

```
class Record {
public:
    mutex rm;
    // ...
};
```

It doesn’t take a genius to guess that for a **Record** called **rec**, you are supposed to acquire **rec.rm** before accessing the rest of **rec**, though a comment or a better name might have helped the reader.

It is not uncommon to need to simultaneously access several resources to perform some action. This can lead to deadlock. For example, if **thread1** acquires **mutex1** and then tries to acquire **mutex2** while **thread2** acquires **mutex2** and then tries to acquire **mutex1**, then neither task will ever proceed further. The **scoped_lock** helps by enabling us to acquire several locks simultaneously:

```
void f()
{
    scoped_lock lck {mutex1,mutex2,mutex3}; // acquire all three locks
    // ... manipulate shared data ...
} // implicitly release all mutexes
```

This `scoped_lock` will proceed only after acquiring all its `mutexes` arguments and will never block (“go to sleep”) while holding a `mutex`. The destructor for `scoped_lock` ensures that the `mutexes` are released when a `thread` leaves the scope.

Communicating through shared data is pretty low level. In particular, the programmer has to devise ways of knowing what work has and has not been done by various tasks. In that regard, use of shared data is inferior to the notion of call and return. On the other hand, some people are convinced that sharing must be more efficient than copying arguments and returns. That can indeed be so when large amounts of data are involved, but locking and unlocking are relatively expensive operations. On the other hand, modern machines are very good at copying data, especially compact data, such as `vector` elements. So don’t choose shared data for communication because of “efficiency” without thought and preferably not without measurement.

The basic `mutex` allows one thread at a time to access data. One of the most common ways of sharing data is among many readers and a single writer. This “reader-writer lock” idiom is supported by `shared_mutex`. A reader will acquire the mutex “shared” so that other readers can still gain access, whereas a writer will demand exclusive access. For example:

```
shared_mutex mx;      // a mutex that can be shared

void reader()
{
    shared_lock lck {mx};      // willing to share access with other readers
    // ... read ...
}

void writer()
{
    unique_lock lck {mx};      // needs exclusive (unique) access
    // ... write ...
}
```

15.6 Waiting for Events

Sometimes, a `thread` needs to wait for some kind of external event, such as another `thread` completing a task or a certain amount of time having passed. The simplest “event” is simply time passing. Using the time facilities found in `<chrono>` I can write:

```
using namespace std::chrono;      // see §13.7

auto t0 = high_resolution_clock::now();
this_thread::sleep_for(milliseconds{20});
auto t1 = high_resolution_clock::now();

cout << duration_cast<nanoseconds>(t1-t0).count() << " nanoseconds passed\n";
```

Note that I didn’t even have to launch a `thread`; by default, `this_thread` refers to the one and only thread.

I used `duration_cast` to adjust the clock's units to the nanoseconds I wanted.

The basic support for communicating using external events is provided by `condition_variables` found in `<condition_variable>`. A `condition_variable` is a mechanism allowing one `thread` to wait for another. In particular, it allows a `thread` to wait for some `condition` (often called an `event`) to occur as the result of work done by other `threads`.

Using `condition_variables` supports many forms of elegant and efficient sharing but can be rather tricky. Consider the classical example of two `threads` communicating by passing messages through a `queue`. For simplicity, I declare the `queue` and the mechanism for avoiding race conditions on that `queue` global to the producer and consumer:

```
class Message {    // object to be communicated
    // ...
};

queue<Message> mqueue;    // the queue of messages
condition_variable mcond;    // the variable communicating events
mutex mmutex;    // for synchronizing access to mcond
```

The types `queue`, `condition_variable`, and `mutex` are provided by the standard library.

The `consumer()` reads and processes `Messages`:

```
void consumer()
{
    while(true) {
        unique_lock lck {mmutex};    // acquire mmutex
        mcond.wait(lck, [] { return !mqueue.empty(); });    // release lck and wait;
        // re-acquire lck upon wakeup
        // don't wake up unless mqueue is non-empty

        auto m = mqueue.front();    // get the message
        mqueue.pop();
        lck.unlock();    // release lck
        // ... process m ...
    }
}
```

Here, I explicitly protect the operations on the `queue` and on the `condition_variable` with a `unique_lock` on the `mutex`. Waiting on `condition_variable` releases its lock argument until the wait is over (so that the queue is non-empty) and then reacquires it. The explicit check of the condition, here `!mqueue.empty()`, protects against waking up just to find that some other task has “gotten there first” so that the condition no longer holds.

I used a `unique_lock` rather than a `scoped_lock` for two reasons:

- We need to pass the lock to the `condition_variable`'s `wait()`. A `scoped_lock` cannot be copied, but a `unique_lock` can be.
- We want to unlock the `mutex` protecting the condition variable before processing the message. A `unique_lock` offers operations, such as `lock()` and `unlock()`, for low-level control of synchronization.

On the other hand, `unique_lock` can only handle a single `mutex`.

The corresponding **producer** looks like this:

```
void producer()
{
    while(true) {
        Message m;
        // ... fill the message ...
        scoped_lock lck {mutex};           // protect operations
        mqueue.push(m);
        mcond.notify_one();                // notify
    }                                       // release lock (at end of scope)
}
```

15.7 Communicating Tasks

The standard library provides a few facilities to allow programmers to operate at the conceptual level of tasks (work to potentially be done concurrently) rather than directly at the lower level of threads and locks:

- **future** and **promise** for returning a value from a task spawned on a separate thread
- **packaged_task** to help launch tasks and connect up the mechanisms for returning a result
- **async()** for launching of a task in a manner very similar to calling a function

These facilities are found in `<future>`.

15.7.1 future and promise

The important point about **future** and **promise** is that they enable a transfer of a value between two tasks without explicit use of a lock; “the system” implements the transfer efficiently. The basic idea is simple: when a task wants to pass a value to another, it puts the value into a **promise**. Somehow, the implementation makes that value appear in the corresponding **future**, from which it can be read (typically by the launcher of the task). We can represent this graphically:

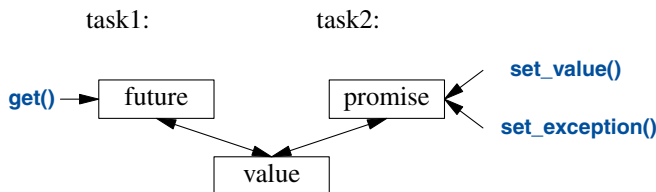

If we have a **future<X>** called **fx**, we can **get()** a value of type **X** from it:

```
X v = fx.get(); // if necessary, wait for the value to get computed
```

If the value isn't there yet, our thread is blocked until it arrives. If the value couldn't be computed, **get()** might throw an exception (from the system or transmitted from the task from which we were trying to **get()** the value).

The main purpose of a **promise** is to provide simple “put” operations (called **set_value()** and **set_exception()**) to match **future**’s **get()**. The names “future” and “promise” are historical; please don’t blame or credit me. They are yet another fertile source of puns.

If you have a **promise** and need to send a result of type **X** to a **future**, you can do one of two things: pass a value or pass an exception. For example:

```
void f(promise<X>& px) // a task: place the result in px
{
    // ...
    try {
        X res;
        // ... compute a value for res ...
        px.set_value(res);
    }
    catch (...) { // oops: couldn't compute res
        px.set_exception(current_exception()); // pass the exception to the future's thread
    }
}
```

The **current_exception()** refers to the caught exception.

To deal with an exception transmitted through a **future**, the caller of **get()** must be prepared to catch it somewhere. For example:

```
void g(future<X>& fx) // a task: get the result from fx
{
    // ...
    try {
        X v = fx.get(); // if necessary, wait for the value to get computed
        // ... use v ...
    }
    catch (...) { // oops: someone couldn't compute v
        // ... handle error ...
    }
}
```

If the error doesn’t need to be handled by **g()** itself, the code reduces to the minimal:

```
void g(future<X>& fx) // a task: get the result from fx
{
    // ...
    X v = fx.get(); // if necessary, wait for the value to get computed
    // ... use v ...
}
```

15.7.2 packaged_task

How do we get a **future** into the task that needs a result and the corresponding **promise** into the thread that should produce that result? The **packaged_task** type is provided to simplify setting up tasks connected with **futures** and **promises** to be run on **threads**. A **packaged_task** provides wrapper code to put the return value or exception from the task into a **promise** (like the code shown in

§15.7.1). If you ask it by calling `get_future`, a `packaged_task` will give you the `future` corresponding to its `promise`. For example, we can set up two tasks to each add half of the elements of a `vector<double>` using the standard-library `accumulate()` (§14.3):

```
double accum(double* beg, double* end, double init)
    // compute the sum of [beg:end) starting with the initial value init
{
    return accumulate(beg,end,init);
}

double comp2(vector<double>& v)
{
    using Task_type = double(double*,double*,double);           // type of task

    packaged_task<Task_type> pt0 {accum};                       // package the task (i.e., accum)
    packaged_task<Task_type> pt1 {accum};

    future<double> f0 {pt0.get_future()};                       // get hold of pt0's future
    future<double> f1 {pt1.get_future()};                       // get hold of pt1's future

    double* first = &v[0];
    thread t1 {move(pt0),first,first+v.size()/2,0};             // start a thread for pt0
    thread t2 {move(pt1),first+v.size()/2,first+v.size(),0};    // start a thread for pt1

    // ...

    return f0.get()+f1.get();                                   // get the results
}
```

The `packaged_task` template takes the type of the task as its template argument (here `Task_type`, an alias for `double(double*,double*,double)`) and the task as its constructor argument (here, `accum`). The `move()` operations are needed because a `packaged_task` cannot be copied. The reason that a `packaged_task` cannot be copied is that it is a resource handle: it owns its `promise` and is (indirectly) responsible for whatever resources its task may own.

Please note the absence of explicit mention of locks in this code: we are able to concentrate on tasks to be done, rather than on the mechanisms used to manage their communication. The two tasks will be run on separate threads and thus potentially in parallel.

15.7.3 `async()`

The line of thinking I have pursued in this chapter is the one I believe to be the simplest yet still among the most powerful: treat a task as a function that may happen to run concurrently with other tasks. It is far from the only model supported by the C++ standard library, but it serves well for a wide range of needs. More subtle and tricky models (e.g., styles of programming relying on shared memory), can be used as needed.

To launch tasks to potentially run asynchronously, we can use `async()`:

```

double comp4(vector<double>& v)
    // spawn many tasks if v is large enough
{
    if (v.size()<10000)        // is it worth using concurrency?
        return accum(v.begin(),v.end(),0.0);

    auto v0 = &v[0];
    auto sz = v.size();

    auto f0 = async(accum,v0,v0+sz/4,0.0);           // first quarter
    auto f1 = async(accum,v0+sz/4,v0+sz/2,0.0);     // second quarter
    auto f2 = async(accum,v0+sz/2,v0+sz*3/4,0.0);   // third quarter
    auto f3 = async(accum,v0+sz*3/4,v0+sz,0.0);     // fourth quarter

    return f0.get()+f1.get()+f2.get()+f3.get(); // collect and combine the results
}

```

Basically, `async()` separates the “call part” of a function call from the “get the result part” and separates both from the actual execution of the task. Using `async()`, you don’t have to think about threads and locks. Instead, you think just in terms of tasks that potentially compute their results asynchronously. There is an obvious limitation: don’t even think of using `async()` for tasks that share resources needing locking. With `async()` you don’t even know how many `threads` will be used because that’s up to `async()` to decide based on what it knows about the system resources available at the time of a call. For example, `async()` may check whether any idle cores (processors) are available before deciding how many `threads` to use.

Using a guess about the cost of computation relative to the cost of launching a `thread`, such as `v.size()<10000`, is very primitive and prone to gross mistakes about performance. However, this is not the place for a proper discussion about how to manage `threads`. Don’t take this estimate as more than a simple and probably poor guess.

It is rarely necessary to manually parallelize a standard-library algorithm, such as `accumulate()`, because the parallel algorithms, such as `reduce(par_unseq,/*...*/)`, usually do a better job at that (§14.3.1). However, the technique is general.

Please note that `async()` is not just a mechanism specialized for parallel computation for increased performance. For example, it can also be used to spawn a task for getting information from a user, leaving the “main program” active with something else (§15.7.3).

15.8 Advice

- [1] Use concurrency to improve responsiveness or to improve throughput; §15.1.
- [2] Work at the highest level of abstraction that you can afford; §15.1.
- [3] Consider processes as an alternative to threads; §15.1.
- [4] The standard-library concurrency facilities are type safe; §15.1.
- [5] The memory model exists to save most programmers from having to think about the machine architecture level of computers; §15.1.

- [6] The memory model makes memory appear roughly as naively expected; §15.1.
- [7] Atomics allow for lock-free programming; §15.1.
- [8] Leave lock-free programming to experts; §15.1.
- [9] Sometimes, a sequential solution is simpler and faster than a concurrent solution; §15.1.
- [10] Avoid data races; §15.1, §15.2.
- [11] Prefer parallel algorithms to direct use of concurrency; §15.1, §15.7.3.
- [12] A **thread** is a type-safe interface to a system thread; §15.2.
- [13] Use **join()** to wait for a **thread** to complete; §15.2.
- [14] Avoid explicitly shared data whenever you can; §15.2.
- [15] Prefer RAII to explicit lock/unlock; §15.5; [CG: CP.20].
- [16] Use **scoped_lock** to manage **mutexes**; §15.5.
- [17] Use **scoped_lock** to acquire multiple locks; §15.5; [CG: CP.21].
- [18] Use **shared_lock** to implement reader-write locks; §15.5;
- [19] Define a **mutex** together with the data it protects; §15.5; [CG: CP.50].
- [20] Use **condition_variables** to manage communication among **threads**; §15.6.
- [21] Use **unique_lock** (rather than **scoped_lock**) when you need to copy a lock or need lower-level manipulation of synchronization; §15.6.
- [22] Use **unique_lock** (rather than **scoped_lock**) with **condition_variables**; §15.6.
- [23] Don't wait without a condition; §15.6; [CG: CP.42].
- [24] Minimize time spent in a critical section; §15.6 [CG: CP.43].
- [25] Think in terms of tasks that can be executed concurrently, rather than directly in terms of **threads**; §15.7.
- [26] Value simplicity; §15.7.
- [27] Prefer **packaged_task** and **futures** over direct use of **threads** and **mutexes**; §15.7.
- [28] Return a result using a **promise** and get a result from a **future**; §15.7.1; [CG: CP.60].
- [29] Use **packaged_tasks** to handle exceptions thrown by tasks and to arrange for value return; §15.7.2.
- [30] Use a **packaged_task** and a **future** to express a request to an external service and wait for its response; §15.7.2.
- [31] Use **async()** to launch simple tasks; §15.7.3; [CG: CP.61].

History and Compatibility

*Hurry Slowly
(festina lente).
– Octavius, Caesar Augustus*

- History
 - Timeline; The Early Years; The ISO C++ Standards; Standards and Programming Style
 - C++ Use
- C++ Feature Evolution
 - C++11 Language Features; C++14 Language Features; C++17 Language Features;
 - C++11 Standard-Library Components; C++14 Standard-Library Components; C++17 Standard-Library Components; Removed and Deprecated Features
- C/C++ Compatibility
 - C and C++ Are Siblings; Compatibility Problems
- Bibliography
- Advice

16.1 History

I invented C++, wrote its early definitions, and produced its first implementation. I chose and formulated the design criteria for C++, designed its major language features, developed or helped to develop many of the early libraries, and for 25 years was responsible for the processing of extension proposals in the C++ standards committee.

C++ was designed to provide Simula's facilities for program organization [Dahl,1970] together with C's efficiency and flexibility for systems programming [Kernighan,1978]. Simula was the initial source of C++'s abstraction mechanisms. The class concept (with derived classes and virtual functions) was borrowed from it. However, templates and exceptions came to C++ later with different sources of inspiration.

The evolution of C++ was always in the context of its use. I spent a lot of time listening to users and seeking out the opinions of experienced programmers. In particular, my colleagues at AT&T Bell Laboratories were essential for the growth of C++ during its first decade.

This section is a brief overview; it does not try to mention every language feature and library component. Furthermore, it does not go into details. For more information, and in particular for more names of people who contributed, see my two papers from the ACM History of Programming Languages conferences [Stroustrup,1993] [Stroustrup,2007] and my *Design and Evolution of C++* book (known as “D&E”) [Stroustrup,1994]. They describe the design and evolution of C++ in detail and document influences from other programming languages.

Most of the documents produced as part of the ISO C++ standards effort are available online [WG21]. In my FAQ, I try to maintain a connection between the standard facilities and the people who proposed and refined those facilities [Stroustrup,2010]. C++ is not the work of a faceless, anonymous committee or of a supposedly omnipotent “dictator for life”; it is the work of many dedicated, experienced, hard-working individuals.

16.1.1 Timeline

The work that led to C++ started in the fall of 1979 under the name “C with Classes.” Here is a simplified timeline:

- 1979 Work on “C with Classes” started. The initial feature set included classes and derived classes, public/private access control, constructors and destructors, and function declarations with argument checking. The first library supported non-preemptive concurrent tasks and random number generators.
- 1984 “C with Classes” was renamed to C++. By then, C++ had acquired virtual functions, function and operator overloading, references, and the I/O stream and complex number libraries.
- 1985 First commercial release of C++ (October 14). The library included I/O streams, complex numbers, and tasks (non-preemptive scheduling).
- 1985 *The C++ Programming Language* (“TC++PL,” October 14) [Stroustrup,1986].
- 1989 *The Annotated C++ Reference Manual* (“the ARM”) [Ellis,1989].
- 1991 *The C++ Programming Language, Second Edition* [Stroustrup,1991], presenting generic programming using templates and error handling based on exceptions, including the “Resource Acquisition Is Initialization” (RAII) general resource-management idiom.
- 1997 *The C++ Programming Language, Third Edition* [Stroustrup,1997] introduced ISO C++, including namespaces, `dynamic_cast`, and many refinements of templates. The standard library added the STL framework of generic containers and algorithms.
- 1998 ISO C++ standard [C++,1998].
- 2002 Work on a revised standard, colloquially named C++0x, started.
- 2003 A “bug fix” revision of the ISO C++ standard was issued. A C++ Technical Report introduced new standard-library components, such as regular expressions, unordered containers (hash tables), and resource management pointers, which later became part of C++11.
- 2006 An ISO C++ Technical Report on Performance addressed questions of cost, predictability, and techniques, mostly related to embedded systems programming [C++,2004].

2011 ISO C++11 standard [C++,2011]. It provided uniform initialization, move semantics, types deduced from initializers (**auto**), range-**for**, variadic template arguments, lambda expressions, type aliases, a memory model suitable for concurrency, and much more. The standard library added several components, including threads, locks, and most of the components from the 2003 Technical Report.

2013 The first complete C++11 implementations emerged.

2013 *The C++ Programming Language, Fourth Edition* introduced C++11.

2014 ISO C++14 standard [C++,2014] completing C++11 with variable templates, digit separators, generic lambdas, and a few standard-library improvements. The first C++14 implementations were completed.

2015 The C++ Core Guidelines projects started [Stroustrup,2015].

2015 The concepts TS was approved.

2017 ISO C++17 standard [C++,2017] offering a diverse set of new features, including order of evaluation guarantees, structured bindings, fold expressions, a file system library, parallel algorithms, and **variant** and **optional** types. The first C++17 implementations were completed.

2017 The modules TS and the Ranges TS were approved.

2020 ISO C++20 standard (scheduled).

During development, C++11 was known as C++0x. As is not uncommon in large projects, we were overly optimistic about the completion date. Towards the end, we joked that the 'x' in C++0x was hexadecimal so that C++0x became C++0B. On the other hand, the committee shipped C++14 and C++17 on time, as did the major compiler providers.

16.1.2 The Early Years

I originally designed and implemented the language because I wanted to distribute the services of a UNIX kernel across multiprocessors and local-area networks (what are now known as multicores and clusters). For that, I needed to precisely specify parts of a system and how they communicated. Simula [Dahl,1970] would have been ideal for that, except for performance considerations. I also needed to deal directly with hardware and provide high-performance concurrent programming mechanisms for which C would have been ideal, except for its weak support for modularity and type checking. The result of adding Simula-style classes to C (Classic C; §16.3.1), “C with Classes,” was used for major projects in which its facilities for writing programs that use minimal time and space were severely tested. It lacked operator overloading, references, virtual functions, templates, exceptions, and many, many details [Stroustrup,1982]. The first use of C++ outside a research organization started in July 1983.

The name C++ (pronounced “see plus plus”) was coined by Rick Mascitti in the summer of 1983 and chosen as the replacement for “C with Classes” by me. The name signifies the evolutionary nature of the changes from C; “++” is the C increment operator. The slightly shorter name “C+” is a syntax error; it had also been used as the name of an unrelated language. Connoisseurs of C semantics find C++ inferior to ++C. The language was not called D, because it was an extension of C, because it did not attempt to remedy problems by removing features, and because there already existed several would-be C successors named D. For yet another interpretation of the name C++, see the appendix of [Orwell,1949].

C++ was designed primarily so that my friends and I would not have to program in assembler, C, or various then-fashionable high-level languages. Its main purpose was to make writing good programs easier and more pleasant for the individual programmer. In the early years, there was no C++ paper design; design, documentation, and implementation went on simultaneously. There was no “C++ project” either, or a “C++ design committee.” Throughout, C++ evolved to cope with problems encountered by users and as a result of discussions among my friends, my colleagues, and me.

The very first design of C++ (then called “C with Classes”) included function declarations with argument type checking and implicit conversions, classes with the **public/private** distinction between the interface and the implementation, derived classes, and constructors and destructors. I used macros to provide primitive parameterization [Stroustrup,1982]. This was in non-experimental use by mid-1980. Late that year, I was able to present a set of language facilities supporting a coherent set of programming styles. In retrospect, I consider the introduction of constructors and destructors most significant. In the terminology of the time [Stroustrup,1979]:

A “new function” creates the execution environment for the member functions and the “delete function” reverses that.

Soon after, “new function” and “delete function” were renamed “constructor” and “destructor.” Here is the root of C++’s strategies for resource management (causing a demand for exceptions) and the key to many techniques for making user code short and clear. If there were other languages at the time that supported multiple constructors capable of executing general code, I didn’t (and don’t) know of them. Destructors were new in C++.

C++ was released commercially in October 1985. By then, I had added inlining (§1.3, §4.2.1), **consts** (§1.6), function overloading (§1.3), references (§1.7), operator overloading (§4.2.1), and virtual functions (§4.4). Of these features, support for run-time polymorphism in the form of virtual functions was by far the most controversial. I knew its worth from Simula but found it impossible to convince most people in the systems programming world of its value. Systems programmers tended to view indirect function calls with suspicion, and people acquainted with other languages supporting object-oriented programming had a hard time believing that **virtual** functions could be fast enough to be useful in systems code. Conversely, many programmers with an object-oriented background had (and many still have) a hard time getting used to the idea that you use virtual function calls only to express a choice that must be made at run time. The resistance to virtual functions may be related to a resistance to the idea that you can get better systems through more regular structure of code supported by a programming language. Many C programmers seem convinced that what really matters is complete flexibility and careful individual crafting of every detail of a program. My view was (and is) that we need every bit of help we can get from languages and tools: the inherent complexity of the systems we are trying to build is always at the edge of what we can express.

Early documents (e.g., [Stroustrup,1985] and [Stroustrup,1994]) described C++ like this:

C++ is a general-purpose programming language that

- *is a better C*
- *supports data abstraction*
- *supports object-oriented programming*

Note *not* “C++ is an object-oriented programming language.” Here, “supports data abstraction” refers to information hiding, classes that are not part of class hierarchies, and generic programming.

Initially, generic programming was poorly supported through the use of macros [Stroustrup,1982]. Templates and concepts came much later.

Much of the design of C++ was done on the blackboards of my colleagues. In the early years, the feedback from Stu Feldman, Alexander Fraser, Steve Johnson, Brian Kernighan, Doug McIlroy, and Dennis Ritchie was invaluable.

In the second half of the 1980s, I continued to add language features in response to user comments. The most important of those were templates [Stroustrup,1988] and exception handling [Koenig,1990], which were considered experimental at the time the standards effort started. In the design of templates, I was forced to decide among flexibility, efficiency, and early type checking. At the time, nobody knew how to simultaneously get all three. To compete with C-style code for demanding systems applications, I felt that I had to choose the first two properties. In retrospect, I think the choice was the correct one, and the search for better type checking of templates continues [DosReis,2006] [Gregor,2006] [Sutton,2011] [Stroustrup,2012a]. The design of exceptions focused on multilevel propagation of exceptions, the passing of arbitrary information to an error handler, and the integration between exceptions and resource management by using local objects with destructors to represent and release resources. I clumsily named that critical technique *Resource Acquisition Is Initialization* and others soon reduced that to the acronym *RAII* (§4.2.2).

I generalized C++'s inheritance mechanisms to support multiple base classes [Stroustrup,1987]. This was called *multiple inheritance* and was considered difficult and controversial. I considered it far less important than templates or exceptions. Multiple inheritance of abstract classes (often called *interfaces*) is now universal in languages supporting static type checking and object-oriented programming.

The C++ language evolved hand-in-hand with some of the key library facilities. For example, I designed the complex [Stroustrup,1984], vector, stack, and (I/O) stream classes [Stroustrup,1985] together with the operator overloading mechanisms. The first string and list classes were developed by Jonathan Shapiro and me as part of the same effort. Jonathan's string and list classes were the first to see extensive use as part of a library. The string class from the standard C++ library has its roots in these early efforts. The task library described in [Stroustrup,1987b] was part of the first "C with Classes" program ever written in 1980. It provided coroutines and a scheduler. I wrote it and its associated classes to support Simula-style simulations. Unfortunately, we had to wait until 2011 (30 years!) to get concurrency support standardized and universally available (Chapter 15). Coroutines are likely to be part of C++20 [CoroutinesTS]. The development of the template facility was influenced by a variety of **vector**, **map**, **list**, and **sort** templates devised by Andrew Koenig, Alex Stepanov, me, and others.

The most important innovation in the 1998 standard library was the STL, a framework of algorithms and containers (Chapter 11, Chapter 12). It was the work of Alex Stepanov (with Dave Musser, Meng Lee, and others) based on more than a decade's work on generic programming. The STL has been massively influential within the C++ community and beyond.

C++ grew up in an environment with a multitude of established and experimental programming languages (e.g., Ada [Ichbiah,1979], Algol 68 [Woodward,1974], and ML [Paulson,1996]). At the time, I was comfortable in about 25 languages, and their influences on C++ are documented in [Stroustrup,1994] and [Stroustrup,2007]. However, the determining influences always came from the applications I encountered. It was a deliberate policy to have the development of C++ "problem driven" rather than imitative.

16.1.3 The ISO C++ Standards

The explosive growth of C++ use caused some changes. Sometime during 1987, it became clear that formal standardization of C++ was inevitable and that we needed to start preparing the ground for a standardization effort [Stroustrup,1994]. The result was a conscious effort to maintain contact between implementers of C++ compilers and their major users. This was done through paper and electronic mail and through face-to-face meetings at C++ conferences and elsewhere.

AT&T Bell Labs made a major contribution to C++ and its wider community by allowing me to share drafts of revised versions of the C++ reference manual with implementers and users. Because many of those people worked for companies that could be seen as competing with AT&T, the significance of this contribution should not be underestimated. A less enlightened company could have caused major problems of language fragmentation simply by doing nothing. As it happened, about a hundred individuals from dozens of organizations read and commented on what became the generally accepted reference manual and the base document for the ANSI C++ standardization effort. Their names can be found in *The Annotated C++ Reference Manual* (“the ARM”) [Ellis,1989]. The X3J16 committee of ANSI was convened in December 1989 at the initiative of Hewlett-Packard. In June 1991, this ANSI (American national) standardization of C++ became part of an ISO (international) standardization effort for C++. The ISO C++ committee is called WG21. From 1990, these joint C++ standards committees have been the main forum for the evolution of C++ and the refinement of its definition. I served on these committees throughout. In particular, as the chairman of the working group for extensions (later called the evolution group) from 1990 to 2014, I was directly responsible for handling proposals for major changes to C++ and the addition of new language features. An initial draft standard for public review was produced in April 1995. The first ISO C++ standard (ISO/IEC 14882-1998) [C++,1998] was ratified by a 22-0 national vote in 1998. A “bug fix release” of this standard was issued in 2003, so you sometimes hear people refer to C++03, but that is essentially the same language as C++98.

C++11, known for years as C++0x, is the work of the members of WG21. The committee worked under increasingly onerous self-imposed processes and procedures. These processes probably led to a better (and more rigorous) specification, but they also limited innovation [Stroustrup,2007]. An initial draft standard for public review was produced in 2009. The second ISO C++ standard (ISO/IEC 14882-2011) [C++,2011] was ratified by a 21-0 national vote in August 2011.

One reason for the long gap between the two standards is that most members of the committee (including me) were under the mistaken impression that the ISO rules required a “waiting period” after a standard was issued before starting work on new features. Consequently, serious work on new language features did not start until 2002. Other reasons included the increased size of modern languages and their foundation libraries. In terms of pages of standards text, the language grew by about 30% and the standard library by about 100%. Much of the increase was due to more detailed specification, rather than new functionality. Also, the work on a new C++ standard obviously had to take great care not to compromise older code through incompatible changes. There are billions of lines of C++ code in use that the committee must not break. Stability over decades is an essential “feature.”

C++11 added massively to the standard library and pushed to complete the feature set needed for a programming style that is a synthesis of the “paradigms” and idioms that had proven successful with C++98.

The overall aims for the C++11 effort were:

- Make C++ a better language for systems programming and library building.
- Make C++ easier to teach and learn.

The aims are documented and detailed in [Stroustrup,2007].

A major effort was made to make concurrent systems programming type-safe and portable. This involved a memory model (§15.1) and support for lock-free programming. This was the work of Hans Boehm, Brian McKnight, and others in the concurrency working group. On top of that, we added the `threads` library.

After C++11, there was wide agreement that 13 years between standards were far too many. Herb Sutter proposed that the committee adopt a policy of shipping on time at fixed intervals, the “train model.” I argued strongly for a short interval between standards to minimize the chance of delays because someone insisted on extra time to allow inclusion of “just one more essential feature.” We agreed on an ambitious 3-year schedule with the idea that we should alternate between minor and major releases.

C++14 was deliberately a minor release aiming at “completing C++11.” This reflects the reality that with a fixed release date, there will be features that we know we want, but can’t deliver on time. Also, once in widespread use, gaps in the feature set will inevitably be discovered.

To allow work to progress faster, to allow parallel development of independent features, and to better utilize the enthusiasm and skills of the many volunteers, the committee makes use of the ISO mechanisms of developing and publishing “Technical Specifications” (TSs). That seems to work well for standard-library components, though it can lead to more stages in the development process, and thus delays. For language features, TSs seems to work less well. Possibly the reason is that few significant language features are truly independent, because the work of crafting standards wording isn’t all that different between a standard and a TS, and because fewer people can experiment with compiler implementations.

C++17 was meant to be a major release. By “major,” I mean containing features that will change the way we think about design and structure our software. By this definition, C++17 was at best a medium release. It included a lot of minor extensions, but the features that would have made dramatic changes (e.g., concepts, modules, and coroutines) were either not ready or became mired in controversy and lack of design direction. As a result, C++17 includes a little bit for everyone, but nothing that will significantly change the life of a C++ programmer who has already absorbed the lessons of C++11 and C++14. I hope that C++20 will be the promised and much-needed major revision, and that the major new features will become widely available well before 2020. The dangers are “Design by committee,” feature bloat, lack of consistent style, and short-sighted decisions. In a committee with well over 100 members present at each meeting and more participating on-line, such undesirable phenomena are almost unavoidable. Making progress toward a simpler-to-use and more coherent language is very hard.

16.1.4 Standards and Style

A standard says what will work, and how. It does not say what constitutes good and effective use. There are significant differences between understanding the technical details of programming language features and using them effectively in combination with other features, libraries, and tools to produce better software. By “better” I mean “more maintainable, less error-prone, and faster.”

We need to develop, popularize, and support coherent programming styles. Further, we must support the evolution of older code to these more modern, effective, and coherent styles.

With the growth of the language and its standard library, the problem of popularizing effective programming styles became critical. It is extremely difficult to make large groups of programmers depart from something that works for something better. There are still people who see C++ as a few minor additions to C and people who consider 1980s Object-Oriented programming styles based on massive class hierarchies the pinnacle of development. Many are struggling to use C++11 well in environments with lots of old C++ code. On the other hand, there are also many who enthusiastically overuse novel facilities. For example, some programmers are convinced that only code using massive amounts of template metaprogramming is true C++.

What is *Modern C++*? In 2015, I set out to answer this question by developing a set of coding guidelines supported by articulated rationales. I soon found that I was not alone in grappling with that problem and together with people from many parts of the world, notably from Microsoft, Red Hat, and Facebook, we started the “C++ Core Guidelines” project [Stroustrup,2015]. This is an ambitious project aiming at complete type-safety and complete resource-safety as a base for simpler, faster, and more maintainable code [Stroustrup,2015b]. In addition to specific coding rules with rationales, we back up the guidelines with static analysis tools and a tiny support library. I see something like that as necessary for moving the C++ community at large forward to benefit from the improvements in language features, libraries, and supporting tools.

16.1.5 C++ Use

C++ is now a very widely used programming language. Its user populations grew quickly from one in 1979 to about 400,000 in 1991; that is, the number of users doubled about every 7.5 months for more than a decade. Naturally, the growth rate slowed since that initial growth spurt, but my best estimate is that there are about 4.5 million C++ programmers in 2018 [Kazakova,2015]. Much of that growth happened after 2005 when the exponential explosion of processor speed stopped so that language performance grew in importance. This growth was achieved without formal marketing or an organized user community.

C++ is primarily an industrial language; that is, it is more prominent in industry than in education or programming language research. It grew up in Bell Labs inspired by the varied and stringent needs of telecommunications and of systems programming (including device drivers, networking, and embedded systems). From there, C++ use has spread into essentially every industry: microelectronics, Web applications and infrastructure, operating systems, financial, medical, automobile, aerospace, high-energy physics, biology, energy production, machine learning, video games, graphics, animation, virtual reality, and much more. It is primarily used where problems require C++’s combination of the ability to use hardware effectively and to manage complexity. This seems to be a continuously expanding set of applications [Stroustrup,1993] [Stroustrup,2014].

16.2 C++ Feature Evolution

Here, I list the language features and standard-library components that have been added to C++ for the C++11, C++14, and C++17 standards.

16.2.1 C++11 Language Features

Looking at a list of language features can be quite bewildering. Remember that a language feature is not meant to be used in isolation. In particular, most features that are new in C++11 make no sense in isolation from the framework provided by older features.

- [1] Uniform and general initialization using `{}`-lists (§1.4, §4.2.3)
- [2] Type deduction from initializer: `auto` (§1.4)
- [3] Prevention of narrowing (§1.4)
- [4] Generalized and guaranteed constant expressions: `constexpr` (§1.6)
- [5] Range-`for`-statement (§1.7)
- [6] Null pointer keyword: `nullptr` (§1.7)
- [7] Scoped and strongly typed `enums`: `enum class` (§2.5)
- [8] Compile-time assertions: `static_assert` (§3.5.5)
- [9] Language mapping of `{}`-list to `std::initializer_list` (§4.2.3)
- [10] Rvalue references, enabling move semantics (§5.2.2)
- [11] Nested template arguments ending with `>>` (no space between the `>`s)
- [12] Lambdas (§6.3.2)
- [13] Variadic templates (§7.4)
- [14] Type and template aliases (§6.4.2)
- [15] Unicode characters
- [16] `long long` integer type
- [17] Alignment controls: `alignas` and `alignof`
- [18] The ability to use the type of an expression as a type in a declaration: `decltype`
- [19] Raw string literals (§9.4)
- [20] Generalized POD (“Plain Old Data”)
- [21] Generalized `unions`
- [22] Local classes as template arguments
- [23] Suffix return type syntax
- [24] A syntax for attributes and two standard attributes: `[[carries_dependency]]` and `[[noreturn]]`
- [25] Preventing exception propagation: the `noexcept` specifier (§3.5.1)
- [26] Testing for the possibility of a `throw` in an expression: the `noexcept` operator.
- [27] C99 features: extended integral types (i.e., rules for optional longer integer types); concatenation of narrow/wide strings; `__STDC_HOSTED__`; `_Pragma(X)`; vararg macros and empty macro arguments
- [28] `__func__` as the name of a string holding the name of the current function
- [29] `inline` namespaces
- [30] Delegating constructors
- [31] In-class member initializers (§5.1.3)
- [32] Control of defaults: `default` and `delete` (§5.1.1)
- [33] Explicit conversion operators
- [34] User-defined literals (§5.4.4)
- [35] More explicit control of `template` instantiation: `extern templates`
- [36] Default template arguments for function templates

- [37] Inheriting constructors
- [38] Override controls: **override** and **final** (§4.5.1)
- [39] A simpler and more general SFINAE (Substitution Failure Is Not An Error) rule
- [40] Memory model (§15.1)
- [41] Thread-local storage: **thread_local**

For a more complete description of the changes to C++98 in C++11, see [Stroustrup,2013].

16.2.2 C++14 Language Features

- [1] Function return-type deduction; §3.6.2
- [2] Improved **constexpr** functions, e.g., **for**-loops allowed (§1.6)
- [3] Variable templates (§6.4.1)
- [4] Binary literals (§1.4)
- [5] Digit separators (§1.4)
- [6] Generic lambdas (§6.3.3)
- [7] More general lambda capture
- [8] **[[deprecated]]** attribute
- [9] A few more minor extensions

16.2.3 C++17 Language Features

- [1] Guaranteed copy elision (§5.2.2)
- [2] Dynamic allocation of over-aligned types
- [3] Stricter order of evaluation (§1.4)
- [4] UTF-8 literals (**u8**)
- [5] Hexadecimal floating-point literals
- [6] Fold expressions (§7.4.1)
- [7] Generic value template arguments (**auto** template parameters)
- [8] Class template argument type deduction (§6.2.3)
- [9] Compile-time **if** (§6.4.3)
- [10] Selection statements with initializers (§1.8)
- [11] **constexpr** lambdas
- [12] **inline** variables
- [13] Structured bindings (§3.6.3)
- [14] New standard attributes: **[[fallthrough]]**, **[[nodiscard]]**, and **[[maybe_unused]]**
- [15] **std::byte** type
- [16] Initialization of an **enum** by a value of its underlying type (§2.5)
- [17] A few more minor extensions

16.2.4 C++11 Standard-Library Components

The C++11 additions to the standard library come in two forms: new components (such as the regular expression matching library) and improvements to C++98 components (such as move constructors for containers).

- [1] `initializer_list` constructors for containers (§4.2.3)
- [2] Move semantics for containers (§5.2.2, §11.2)
- [3] A singly-linked list: `forward_list` (§11.6)
- [4] Hash containers: `unordered_map`, `unordered_multimap`, `unordered_set`, and `unordered_multiset` (§11.6, §11.5)
- [5] Resource management pointers: `unique_ptr`, `shared_ptr`, and `weak_ptr` (§13.2.1)
- [6] Concurrency support: `thread` (§15.2), mutexes (§15.5), locks (§15.5), and condition variables (§15.6)
- [7] Higher-level concurrency support: `packaged_thread`, `future`, `promise`, and `async()` (§15.7)
- [8] `tuples` (§13.4.3)
- [9] Regular expressions: `regex` (§9.4)
- [10] Random numbers: distributions and engines (§14.5)
- [11] Integer type names, such as `int16_t`, `uint32_t`, and `int_fast64_t`
- [12] A fixed-sized contiguous sequence container: `array` (§13.4.1)
- [13] Copying and rethrowing exceptions (§15.7.1)
- [14] Error reporting using error codes: `system_error`
- [15] `emplace()` operations for containers (§11.6)
- [16] Wide use of `constexpr` functions
- [17] Systematic use of `noexcept` functions
- [18] Improved function adaptors: `function` and `bind()` (§13.8)
- [19] `string` to numeric value conversions
- [20] Scoped allocators
- [21] Type traits, such as `is_integral` and `is_base_of` (§13.9.2)
- [22] Time utilities: `duration` and `time_point` (§13.7)
- [23] Compile-time rational arithmetic: `ratio`
- [24] Abandoning a process: `quick_exit`
- [25] More algorithms, such as `move()`, `copy_if()`, and `is_sorted()` (Chapter 12)
- [26] Garbage collection API (§5.3)
- [27] Low-level concurrency support: `atomics`

16.2.5 C++14 Standard-Library Components

- [1] `shared_mutex` (§15.5)
- [2] User-defined literals (§5.4.4)
- [3] Tuple addressing by type (§13.4.3)
- [4] Associative container heterogeneous lookup
- [5] A few more minor features

16.2.6 C++17 Standard-Library Components

- [1] File system (§10.10)
- [2] Parallel algorithms (§12.9, §14.3.1)
- [3] Mathematical special functions (§14.2)
- [4] `string_view` (§9.3)

- [5] **any** (§13.5.3)
- [6] **variant** (§13.5.1)
- [7] **optional** (§13.5.2)
- [8] **invoke()**
- [9] Elementary string conversions: **to_chars** and **from_chars**
- [10] Polymorphic allocator (§13.6)
- [11] A few more minor extensions

16.2.7 Removed and Deprecated Features

There are billions of lines of C++ “out there” and nobody knows exactly what features are in critical use. Consequently, the ISO committee removes older features only reluctantly and after years of warning. However, sometimes troublesome features are removed:

- C++17 finally removed exceptions specifications:

```
void f() throw(X,Y); // C++98; now an error
```

The support facilities for exception specifications, **unexpected_handler**, **set_unexpected()**, **get_unexpected()**, and **unexpected()**, are similarly removed. Instead, use **noexcept** (§3.5.1).

- Trigraphs are no longer supported.
- The **auto_ptr** is deprecated. Instead, use **unique_ptr** (§13.2.1).
- The use of the storage specifier **register** is removed.
- The use of **++** on a **bool** is removed.
- The C++98 **export** feature was removed because it was complex and not shipped by the major vendors. Instead, **export** is used as a keyword for modules (§3.3).
- Generation of copy operations is deprecated for a class with a destructor (§5.1.1).
- Assignment of a string literal to a **char*** is removed. Instead use **const char*** or **auto**.
- Some C++ standard-library function objects and associated functions are deprecated. Most relate to argument binding. Instead use lambdas and **function** (§13.8).

By deprecating a feature, the standards committee expresses the wish that the feature will go away. However, the committee does not have a mandate to immediately remove a heavily used feature – however redundant or dangerous it may be. Thus, a deprecation is a strong hint to avoid the feature. It may disappear in the future. Compilers are likely to issue warnings for uses of deprecated features. However, deprecated features are part of the standard and history shows that they tend to remain supported “forever” for reasons of compatibility.

16.3 C/C++ Compatibility

With minor exceptions, C++ is a superset of C (meaning C11; [C,2011]). Most differences stem from C++’s greater emphasis on type checking. Well-written C programs tend to be C++ programs as well. A compiler can diagnose every difference between C++ and C. The C99/C++11 incompatibilities are listed in Appendix C of the standard.

16.3.1 C and C++ Are Siblings

Classic C has two main descendants: ISO C and ISO C++. Over the years, these languages have evolved at different paces and in different directions. One result of this is that each language provides support for traditional C-style programming in slightly different ways. The resulting incompatibilities can make life miserable for people who use both C and C++, for people who write in one language using libraries implemented in the other, and for implementers of libraries and tools for C and C++.

How can I call C and C++ siblings? Look at a simplified family tree:

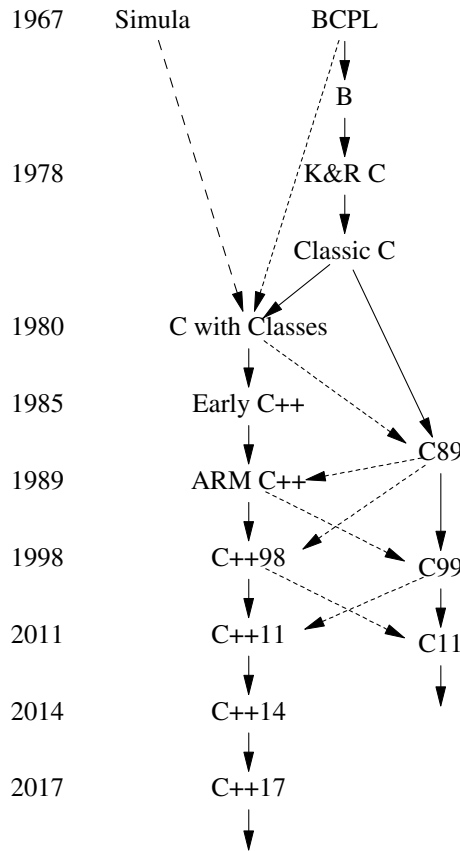

A solid line means a massive inheritance of features, a dashed line a borrowing of major features, and a dotted line a borrowing of minor features. From this, ISO C and ISO C++ emerge as the two major descendants of K&R C [Kernighan,1978], and as siblings. Each carries with it the key aspects of Classic C, and neither is 100% compatible with Classic C. I picked the term “Classic C” from a sticker that used to be affixed to Dennis Ritchie’s terminal. It is K&R C plus enumerations and `struct` assignment. BCPL is defined by [Richards,1980] and C89 by [C1990].

Note that differences between C and C++ are not necessarily the result of changes to C made in C++. In several cases, the incompatibilities arise from features adopted incompatibly into C long after they were common in C++. Examples are the ability to assign a **T*** to a **void*** and the linkage of global **consts** [Stroustrup,2002]. Sometimes, a feature was even incompatibly adopted into C after it was part of the ISO C++ standard, such as details of the meaning of **inline**.

16.3.2 Compatibility Problems

There are many minor incompatibilities between C and C++. All can cause problems for a programmer, but all can be coped with in the context of C++. If nothing else, C code fragments can be compiled as C and linked to using the **extern "C"** mechanism.

The major problems for converting a C program to C++ are likely to be:

- Suboptimal design and programming style.
- A **void*** implicitly converted to a **T*** (that is, converted without a cast).
- C++ keywords, such as **class** and **private**, used as identifiers in C code.
- Incompatible linkage of code fragments compiled as C and fragments compiled as C++.

16.3.2.1 Style Problems

Naturally, a C program is written in a C style, such as the style used in K&R [Kernighan,1988]. This implies widespread use of pointers and arrays, and probably many macros. These facilities are hard to use reliably in a large program. Resource management and error handling are often ad hoc, documented (rather than language and tool supported), and often incompletely documented and adhered to. A simple line-for-line conversion of a C program into a C++ program yields a program that is often a bit better checked. In fact, I have never converted a C program into C++ without finding some bug. However, the fundamental structure is unchanged, and so are the fundamental sources of errors. If you had incomplete error handling, resource leaks, or buffer overflows in the original C program, they will still be there in the C++ version. To obtain major benefits, you must make changes to the fundamental structure of the code:

- [1] Don't think of C++ as C with a few features added. C++ can be used that way, but only suboptimally. To get really major advantages from C++ as compared to C, you need to apply different design and implementation styles.
- [2] Use the C++ standard library as a teacher of new techniques and programming styles. Note the difference from the C standard library (e.g., **=** rather than **strcpy()** for copying and **==** rather than **strcmp()** for comparing).
- [3] Macro substitution is almost never necessary in C++. Use **const** (§1.6), **constexpr** (§1.6), **enum** or **enum class** (§2.5) to define manifest constants, **inline** (§4.2.1) to avoid function-calling overhead, **templates** (Chapter 6) to specify families of functions and types, and **namespaces** (§3.4) to avoid name clashes.
- [4] Don't declare a variable before you need it and initialize it immediately. A declaration can occur anywhere a statement can (§1.8), in **for**-statement initializers (§1.7), and in conditions (§4.5.2).
- [5] Don't use **malloc()**. The **new** operator (§4.2.2) does the same job better, and instead of **realloc()**, try a **vector** (§4.2.3, §12.1). Don't just replace **malloc()** and **free()** with "naked" **new** and **delete** (§4.2.2).

- [6] Avoid `void*`, unions, and casts, except deep within the implementation of some function or class. Their use limits the support you can get from the type system and can harm performance. In most cases, a cast is an indication of a design error.
- [7] If you must use an explicit type conversion, use an appropriate named cast (e.g., `static_cast`; §16.2.7) for a more precise statement of what you are trying to do.
- [8] Minimize the use of arrays and C-style strings. C++ standard-library `strings` (§9.2), `arrays` (§13.4.1), and `vectors` (§11.2) can often be used to write simpler and more maintainable code compared to the traditional C style. In general, try not to build yourself what has already been provided by the standard library.
- [9] Avoid pointer arithmetic except in very specialized code (such as a memory manager) and for simple array traversal (e.g., `++p`).
- [10] Do not assume that something laboriously written in C style (avoiding C++ features such as classes, templates, and exceptions) is more efficient than a shorter alternative (e.g., using standard-library facilities). Often (but of course not always), the opposite is true.

16.3.2.2 `void*`

In C, a `void*` may be used as the right-hand operand of an assignment to or initialization of a variable of any pointer type; in C++ it may not. For example:

```
void f(int n)
{
    int* p = malloc(n*sizeof(int)); /* not C++; in C++, allocate using "new" */
    // ...
}
```

This is probably the single most difficult incompatibility to deal with. Note that the implicit conversion of a `void*` to a different pointer type is *not* in general harmless:

```
char ch;
void* pv = &ch;
int* pi = pv;           // not C++
*pi = 666;             // overwrite ch and other bytes near ch
```

In both languages, cast the result of `malloc()` to the right type. If you use only C++, avoid `malloc()`.

16.3.2.3 Linkage

C and C++ can (and often are) implemented to use different linkage conventions. The most basic reason for that is C++'s greater emphasis on type checking. A practical reason is that C++ supports overloading, so there can be two global functions called `open()`. This has to be reflected in the way the linker works.

To give a C++ function C linkage (so that it can be called from a C program fragment) or to allow a C function to be called from a C++ program fragment, declare it `extern "C"`. For example:

```
extern "C" double sqrt(double);
```

Now `sqrt(double)` can be called from a C or a C++ code fragment. The definition of `sqrt(double)` can also be compiled as a C function or as a C++ function.

Only one function of a given name in a scope can have C linkage (because C doesn't allow function overloading). A linkage specification does not affect type checking, so the C++ rules for function calls and argument checking still apply to a function declared `extern "C"`.

16.4 Bibliography

- [Boost] *The Boost Libraries: free peer-reviewed portable C++ source libraries.* www.boost.org.
- [C,1990] X3 Secretariat: *Standard – The C Language.* X3J11/90-013. ISO Standard ISO/IEC 9899-1990. Computer and Business Equipment Manufacturers Association. Washington, DC.
- [C,1999] ISO/IEC 9899. *Standard – The C Language.* X3J11/90-013-1999.
- [C,2011] ISO/IEC 9899. *Standard – The C Language.* X3J11/90-013-2011.
- [C++,1998] ISO/IEC JTC1/SC22/WG21 (editor: Andrew Koenig): *International Standard – The C++ Language.* ISO/IEC 14882:1998.
- [C++,2004] ISO/IEC JTC1/SC22/WG21 (editor: Lois Goldtwaite): *Technical Report on C++ Performance.* ISO/IEC TR 18015:2004(E)
- [C++Math,2010] *International Standard – Extensions to the C++ Library to Support Mathematical Special Functions.* ISO/IEC 29124:2010.
- [C++,2011] ISO/IEC JTC1/SC22/WG21 (editor: Pete Becker): *International Standard – The C++ Language.* ISO/IEC 14882:2011.
- [C++,2014] ISO/IEC JTC1/SC22/WG21 (editor: Stefanus du Toit): *International Standard – The C++ Language.* ISO/IEC 14882:2014.
- [C++,2017] ISO/IEC JTC1/SC22/WG21 (editor: Richard Smith): *International Standard – The C++ Language.* ISO/IEC 14882:2017.
- [ConceptsTS] ISO/IEC JTC1/SC22/WG21 (editor: Gabriel Dos Reis): *Technical Specification: C++ Extensions for Concepts.* ISO/IEC TS 19217:2015.
- [CoroutinesTS] ISO/IEC JTC1/SC22/WG21 (editor: Gor Nishanov): *Technical Specification: C++ Extensions for Coroutines.* ISO/IEC TS 22277:2017.
- [Cplusplusreference] *Online source for C++ language and standard library facilities.* www.cppreference.com.
- [Cox,2007] Russ Cox: *Regular Expression Matching Can Be Simple And Fast.* January 2007. swtch.com/~rsc/regexp/regexp1.html.
- [Dahl,1970] O-J. Dahl, B. Myrhaug, and K. Nygaard: *SIMULA Common Base Language.* Norwegian Computing Center S-22. Oslo, Norway. 1970.
- [Dechev,2010] D. Dechev, P. Pirkelbauer, and B. Stroustrup: *Understanding and Effectively Preventing the ABA Problem in Descriptor-based Lock-free Designs.* 13th IEEE Computer Society ISORC 2010 Symposium. May 2010.
- [DosReis,2006] Gabriel Dos Reis and Bjarne Stroustrup: *Specifying C++ Concepts.* POPL06. January 2006.
- [Ellis,1989] Margaret A. Ellis and Bjarne Stroustrup: *The Annotated C++ Reference Manual.* Addison-Wesley. Reading, Massachusetts. 1990. ISBN 0-201-51459-1.

- [Garcia,2015] J. Daniel Garcia and B. Stroustrup: *Improving performance and maintainability through refactoring in C++11*. Isocpp.org. August 2015. http://www.stroustrup.com/improving_garcia_stroustrup_2015.pdf.
- [Garcia,2016] G. Dos Reis, J. D. Garcia, J. Lakos, A. Meredith, N. Myers, B. Stroustrup: *A Contract Design*. P0380R1. 2016-7-11.
- [Garcia,2018] G. Dos Reis, J. D. Garcia, J. Lakos, A. Meredith, N. Myers, B. Stroustrup: *Support for contract based programming in C++*. P0542R4. 2018-4-2.
- [Friedl,1997] Jeffrey E. F. Friedl: *Mastering Regular Expressions*. O'Reilly Media. Sebastopol, California. 1997. ISBN 978-1565922570.
- [GSL] N. MacIntosh (Editor): *Guidelines Support Library*. <https://github.com/microsoft/gsl>.
- [Gregor,2006] Douglas Gregor et al.: *Concepts: Linguistic Support for Generic Programming in C++*. OOPSLA'06.
- [Hinnant,2018] Howard Hinnant: *Date*. <https://howardhinnant.github.io/date/date.html>. Github. 2018.
- [Hinnant,2018b] Howard Hinnant: *Timezones*. <https://howardhinnant.github.io/date/tz.html>. Github. 2018.
- [Ichbiah,1979] Jean D. Ichbiah et al.: *Rationale for the Design of the ADA Programming Language*. SIGPLAN Notices. Vol. 14, No. 6. June 1979.
- [Kazakova,2015] Anastasia Kazakova: *Infographic: C/C++ facts*. <https://blog.jetbrains.com/clion/2015/07/infographics-cpp-facts-before-clion/> July 2015.
- [Kernighan,1978] Brian W. Kernighan and Dennis M. Ritchie: *The C Programming Language*. Prentice Hall. Englewood Cliffs, New Jersey. 1978.
- [Kernighan,1988] Brian W. Kernighan and Dennis M. Ritchie: *The C Programming Language, Second Edition*. Prentice-Hall. Englewood Cliffs, New Jersey. 1988. ISBN 0-13-110362-8.
- [Knuth,1968] Donald E. Knuth: *The Art of Computer Programming*. Addison-Wesley. Reading, Massachusetts. 1968.
- [Koenig,1990] A. R. Koenig and B. Stroustrup: *Exception Handling for C++ (revised)*. Proc USENIX C++ Conference. April 1990.
- [Maddock,2009] John Maddock: *Boost.Regex*. www.boost.org. 2009. 2017.
- [ModulesTS] ISO/IEC JTC1/SC22/WG21 (editor: Gabriel Dos Reis): *Technical Specification: C++ Extensions for Modules*. ISO/IEC TS 21544:2018.
- [Orwell,1949] George Orwell: *1984*. Secker and Warburg. London. 1949.
- [Paulson,1996] Larry C. Paulson: *ML for the Working Programmer*. Cambridge University Press. Cambridge. 1996.
- [RangesTS] ISO/IEC JTC1/SC22/WG21 (editor: Eric Niebler): *Technical Specification: C++ Extensions for Ranges*. ISO/IEC TS 21425:2017. ISBN 0-521-56543-X.
- [Richards,1980] Martin Richards and Colin Whitby-Stevens: *BCPL – The Language and Its Compiler*. Cambridge University Press. Cambridge. 1980. ISBN 0-521-21965-5.

- [Stepanov,1994] Alexander Stepanov and Meng Lee: *The Standard Template Library*. HP Labs Technical Report HPL-94-34 (R. 1). 1994.
- [Stepanov,2009] Alexander Stepanov and Paul McJones: *Elements of Programming*. Addison-Wesley. 2009. ISBN 978-0-321-63537-2.
- [Stroustrup,1979] Personal lab notes.
- [Stroustrup,1982] B. Stroustrup: *Classes: An Abstract Data Type Facility for the C Language*. Sigplan Notices. January 1982. The first public description of “C with Classes.”
- [Stroustrup,1984] B. Stroustrup: *Operator Overloading in C++*. Proc. IFIP WG2.4 Conference on System Implementation Languages: Experience & Assessment. September 1984.
- [Stroustrup,1985] B. Stroustrup: *An Extensible I/O Facility for C++*. Proc. Summer 1985 USENIX Conference.
- [Stroustrup,1986] B. Stroustrup: *The C++ Programming Language*. Addison-Wesley. Reading, Massachusetts. 1986. ISBN 0-201-12078-X.
- [Stroustrup,1987] B. Stroustrup: *Multiple Inheritance for C++*. Proc. EUUG Spring Conference. May 1987.
- [Stroustrup,1987b] B. Stroustrup and J. Shopiro: *A Set of C Classes for Co-Routine Style Programming*. Proc. USENIX C++ Conference. Santa Fe, New Mexico. November 1987.
- [Stroustrup,1988] B. Stroustrup: *Parameterized Types for C++*. Proc. USENIX C++ Conference, Denver, Colorado. 1988.
- [Stroustrup,1991] B. Stroustrup: *The C++ Programming Language (Second Edition)*. Addison-Wesley. Reading, Massachusetts. 1991. ISBN 0-201-53992-6.
- [Stroustrup,1993] B. Stroustrup: *A History of C++: 1979–1991*. Proc. ACM History of Programming Languages Conference (HOPL-2). ACM Sigplan Notices. Vol 28, No 3. 1993.
- [Stroustrup,1994] B. Stroustrup: *The Design and Evolution of C++*. Addison-Wesley. Reading, Massachusetts. 1994. ISBN 0-201-54330-3.
- [Stroustrup,1997] B. Stroustrup: *The C++ Programming Language, Third Edition*. Addison-Wesley. Reading, Massachusetts. 1997. ISBN 0-201-88954-4. Hardcover (“Special”) Edition. 2000. ISBN 0-201-70073-5.
- [Stroustrup,2002] B. Stroustrup: *C and C++: Siblings, C and C++: A Case for Compatibility, and C and C++: Case Studies in Compatibility*. The C/C++ Users Journal. July–September 2002. www.stroustrup.com/papers.html.
- [Stroustrup,2007] B. Stroustrup: *Evolving a language in and for the real world: C++ 1991–2006*. ACM HOPL-III. June 2007.
- [Stroustrup,2009] B. Stroustrup: *Programming – Principles and Practice Using C++*. Addison-Wesley. 2009. ISBN 0-321-54372-6.
- [Stroustrup,2010] B. Stroustrup: *The C++11 FAQ*. www.stroustrup.com/C++11FAQ.html.
- [Stroustrup,2012a] B. Stroustrup and A. Sutton: *A Concept Design for the STL*. WG21 Technical Report N3351==12-0041. January 2012.
- [Stroustrup,2012b] B. Stroustrup: *Software Development for Infrastructure*. Computer. January 2012. doi:10.1109/MC.2011.353.

- [Stroustrup,2013] B. Stroustrup: *The C++ Programming Language (Fourth Edition)*. Addison-Wesley. 2013. ISBN 0-321-56384-0.
- [Stroustrup,2014] B. Stroustrup: C++ Applications. <http://www.stroustrup.com/applications.html>.
- [Stroustrup,2015] B. Stroustrup and H. Sutter: *C++ Core Guidelines*. <https://github.com/isocpp/CppCoreGuidelines/blob/master/CppCoreGuidelines.md>.
- [Stroustrup,2015b] B. Stroustrup, H. Sutter, and G. Dos Reis: *A brief introduction to C++'s model for type- and resource-safety*. Isocpp.org. October 2015. Revised December 2015. <http://www.stroustrup.com/resource-model.pdf>.
- [Sutton,2011] A. Sutton and B. Stroustrup: *Design of Concept Libraries for C++*. Proc. SLE 2011 (International Conference on Software Language Engineering). July 2011.
- [WG21] ISO SC22/WG21 The C++ Programming Language Standards Committee: *Document Archive*. www.open-std.org/jtc1/sc22/wg21.
- [Williams,2012] Anthony Williams: *C++ Concurrency in Action – Practical Multithreading*. Manning Publications Co. ISBN 978-1933988771.
- [Woodward,1974] P. M. Woodward and S. G. Bond: *Algol 68-R Users Guide*. Her Majesty's Stationery Office. London. 1974.

16.5 Advice

- [1] The ISO C++ standard [C++,2017] defines C++.
- [2] When choosing a style for a new project or when modernizing a code base, rely on the C++ Core Guidelines; §16.1.4.
- [3] When learning C++, don't focus on language features in isolation; §16.2.1.
- [4] Don't get stuck with decades-old language-feature sets and design techniques; §16.1.4.
- [5] Before using a new feature in production code, try it out by writing small programs to test the standards conformance and performance of the implementations you plan to use.
- [6] For learning C++, use the most up-to-date and complete implementation of Standard C++ that you can get access to.
- [7] The common subset of C and C++ is not the best initial subset of C++ to learn; §16.3.2.1.
- [8] Prefer named casts, such as `static_cast` over C-style casts; §16.2.7.
- [9] When converting a C program to C++, first make sure that function declarations (prototypes) and standard headers are used consistently; §16.3.2.
- [10] When converting a C program to C++, rename variables that are C++ keywords; §16.3.2.
- [11] For portability and type safety, if you must use C, write in the common subset of C and C++; §16.3.2.1.
- [12] When converting a C program to C++, cast the result of `malloc()` to the proper type or change all uses of `malloc()` to uses of `new`; §16.3.2.2.
- [13] When converting from `malloc()` and `free()` to `new` and `delete`, consider using `vector`, `push_back()`, and `reserve()` instead of `realloc()`; §16.3.2.1.

- [14] In C++, there are no implicit conversions from `ints` to enumerations; use explicit type conversion where necessary.
- [15] For each standard C header `<X.h>` that places names in the global namespace, the header `<cX>` places the names in namespace `std`.
- [16] Use `extern "C"` when declaring C functions; §16.3.2.3.
- [17] Prefer `string` over C-style strings (direct manipulation of zero-terminated arrays of `char`).
- [18] Prefer `iostreams` over `stdio`.
- [19] Prefer containers (e.g., `vector`) over built-in arrays.

Index

*Knowledge is of two kinds.
We know a subject ourselves,
or we know where
we can find information on it.
– Samuel Johnson*

Token

!=
 container 147
 not-equal operator 6
", string literal 3
\$, [regex](#) 117
%
 modulus operator 6
 remainder operator 6
%=: operator 7
&
 address-of operator 11
 reference to 12
&&, rvalue reference 71
([, regex](#) 117
(), call operator 85
(?: pattern 120
), [, regex](#) 117
*
 contents-of operator 11
 multiply operator 6
 pointer to 11
 [regex](#) 117
*=, scaling operator 7
*? lazy 118
+
 plus operator 6
 [regex](#) 117
 string concatenation 111
++, increment operator 7
+=
 operator 7
 string append 112
+? lazy 118
-, minus operator 6
--, decrement operator 7
., [, regex](#) 117
/, divide operator 6
// comment 2
/=, scaling operator 7
: [public](#) 55
<< 75
 output operator 3
<=
 container 147
 less-than-or-equal operator 6
<
 container 147
 less-than operator 6
=
 0 54
 and == 7

- assignment 16
 - `auto` 8
 - container 147
 - initializer 7
 - initializer narrowing 8
 - `string` assignment 112
 - `==`
 - `=` and 7
 - container 147
 - equal operator 6
 - `string` 112
 - `>`
 - container 147
 - greater-than operator 6
 - `>=`
 - container 147
 - greater-than-or-equal operator 6
 - `>>`
 - 75
 - `template` arguments 215
 - `?, regex` 117
 - `??` lazy 118
 - `[, regex` 117
 - `[]`
 - `array` 171
 - array of 11
 - `string` 112
 - `\`, backslash 3
 - `], regex` 117
 - `^, regex` 117
 - `{, regex` 117
 - `{}`
 - grouping 2
 - initializer 8
 - `{}?` lazy 118
 - `|, regex` 117
 - `}, regex` 117
 - `~`, destructor 51
 - `0`
 - `=` 54
 - `nullptr` `NULL` 13
- A**
- `abs()` 188
 - abstract
 - `class` 54
 - type 54
 - `accumulate()` 189
 - acquisition RAI, resource 164
 - adaptor, lambda as 180
 - address, memory 16
 - address-of operator `&` 11
 - `adjacent_difference()` 189
 - aims, C++11 213
 - algorithm 149
 - container 150, 160
 - lifting 100
 - numerical 189
 - parallel 161
 - standard library 156
 - `<algorithm>` 109, 156
 - alias
 - `template` 184
 - `using` 90
 - `alignas` 215
 - `alignof` 215
 - allocation 51
 - allocator `new`, container 178
 - almost container 170
 - `alnum, regex` 119
 - `alpha, regex` 119
 - `[[:alpha:]]` letter 119
 - ANSI C++ 212
 - `any` 177
 - append `+=, string` 112
 - argument
 - constrained 81
 - constrained `template` 82
 - default function 42
 - default `template` 98
 - function 41
 - passing, function 66
 - type 82
 - value 82
 - arithmetic
 - conversions, usual 7
 - operator 6
 - vector 192
 - ARM 212
 - array
 - `array` vs. 172
 - of `[]` 11
 - `array` 171
 - `[]` 171
 - `data()` 171
 - initialize 171
 - `size()` 171
 - vs. array 172
 - vs. `vector` 171
 - `<array>` 109
 - `asin()` 188
 - assembler 210
 - `assert()` 40
 - assertion `static_assert` 40
 - `Assignable`, concept 158
 - assignment
 - `=` 16
 - `-=, string` 112
 - copy 66, 69
 - initialization and 18
 - move 66, 72
 - associative array – see `map`

async() launch 204
 at() 141
 atan() 188
 atan2() 188
 AT&T Bell Laboratories 212
 auto = 8
 auto_ptr, deprecated 218

B

back_inserter() 150
 backslash \ 3
 bad_variant_access 176
 base and derived class 55
 basic_string 114
 BCPPL 219
 begin() 75, 143, 147, 150
 beginner, book for 1
 Bell Laboratories, AT&T 212
 beta() 188
 bibliography 222
 BidirectionalIterator, concept 159
 BidirectionalRange, concept 160
 binary search 156
 binding, structured 45
 bit-field, **bitset** and 172
bitset 172
 and bit-field 172
 and **enum** 172
 blank, **regex** 119
 block
 as function body, **try** 141
 try 36
 body, function 2
 book for beginner 1
bool 5
 Boolean, concept 158
 BoundedRange, concept 160
break 15

C

C 209
 and C++ compatibility 218
 Classic 219
 difference from 218
 K&R 219
 void* assignment, difference from 221
 with Classes 208
 with Classes language features 210
 with Classes standard library 211
 C++
 ANSI 212
 compatibility, C and 218
 Core Guidelines 214

 core language 2
 history 207
 ISO 212
 meaning 209
 modern 214
 pronunciation 209
 standard, ISO 2
 standard library 2
 standardization 212
 timeline 208
 C++03 212
 C++0x, C++11 209, 212
 C++11
 aims 213
 C++0x 209, 212
 language features 215
 library components 216
 C++14 213
 language features 216
 library components 217
 C++17 1, 213
 language features 216
 library components 217
 C++20 1, 157, 213
 concepts 94
 contracts 40
 modules 32
 C++98 212
 standard library 211
 C11 218
 C89 and C99 218
 C99, C89 and 218
 call operator () 85
 callback 181
 capacity() 139, 147
 capture list 87
 carries_dependency 215
 cast 53
catch
 clause 36
 every exception 141
 catch(...) 141
 ceil() 188
char 5
 character sets, multiple 114
 check
 compile-time 40
 run-time 40
 checking, cost of range 142
 chrono, namespace 179
 <chrono> 109, 179, 200
class 48
 abstract 54
 base and derived 55
 concrete 48
 hierarchy 57

- scope 9
- template** 79
- Classic C 219
- C-library header 110
- clock timing 200
- <cmath> 109, 188
- cntrl, regex 119
- code complexity, function and 4
- comment, // 2
- Common, concept 158
- CommonReference, concept 158
- common_type_t 158
- communication, task 202
- comparison 74
 - operator 6, 74
- compatibility, C and C++ 218
- compilation
 - model, **template** 104
 - separate 30
- compiler 2
- compile-time
 - check 40
 - computation 181
 - evaluation 10
- complete encapsulation 66
- complex 49, 190
- <complex> 109, 188, 190
- complexity, function and code 4
- components
 - C++11 library 216
 - C++14 library 217
 - C++17 library 217
- computation, compile-time 181
- concatenation +, **string** 111
- concept 81, 94
 - Assignable** 158
 - based overloading 95
 - BidirectionalIterator** 159
 - BidirectionalRange** 160
 - Boolean** 158
 - BoundedRange** 160
 - Common** 158
 - CommonReference** 158
 - Constructible** 158
 - ConvertibleTo** 158
 - Copyable** 158
 - CopyConstructible** 158
 - DefaultConstructible** 158
 - DerivedFrom** 158
 - Destructible** 158
 - EqualityComparable** 158
 - ForwardIterator** 159
 - ForwardRange** 160
 - InputIterator** 159
 - InputRange** 160
 - Integral** 158
 - Invocable** 159
 - InvocableRegular** 159
 - Iterator** 159
 - Mergeable** 159
 - Movable** 158
 - MoveConstructible** 158
 - OutputIterator** 159
 - OutputRange** 160
 - Permutable** 159
 - Predicate** 159
 - RandomAccessIterator** 159
 - RandomAccessRange** 160
 - Range** 157
 - Range** 160
 - Regular** 158
 - Relation** 159
 - Same** 158
 - Semiregular** 158
 - Sentinel** 159
 - SignedIntegral** 158
 - SizedRange** 160
 - SizedSentinel** 159
 - Sortable** 159
 - StrictTotallyOrdered** 158
 - StrictWeakOrder** 159
 - support 94
 - Swappable** 158
 - SwappableWith** 158
 - UnsignedIntegral** 158
 - use 94
 - View** 160
 - WeaklyEqualityComparable** 158
- concepts
 - C++20 94
 - definition of 97
 - in <concepts> 158
 - in <iterator> 158
 - in <ranges> 158
 - <concepts>, concepts in 158
- concrete
 - class** 48
 - type 48
- concurrency 195
- condition, declaration in 61
- condition_variable** 201
 - notify_one() 202
 - wait() 201
- <condition_variable> 201
- const**
 - immutability 9
 - member function 50
- constant expression 10
- const_cast** 53
- constexpr**
 - function 10
 - immutability 9

[const_iterator](#) 154
 constrained
 argument 81
 [template](#) 82
 [template](#) argument 82
[Constructible](#), concept 158
 constructor
 and destructor 210
 copy 66, 69
 default 50
 delegating 215
 [explicit](#) 67
 inheriting 216
 initializer-list 52
 invariant and 37
 move 66, 71
 container 51, 79, 137
 >= 147
 > 147
 = 147
 == 147
 < 147
 <= 147
 != 147
 algorithm 150, 160
 allocator [new](#) 178
 almost 170
 object in 140
 overview 146
 [return](#) 151
 [sort\(\)](#) 181
 specialized 170
 standard library 146
 contents-of operator * 11
 contract 40
 contracts, C++20 40
 conversion 67
 explicit type 53
 narrowing 8
 conversions, usual arithmetic 7
[ConvertibleTo](#), concept 158
 copy 68
 assignment 66, 69
 constructor 66, 69
 cost of 70
 elision 72
 elision 66
 memberwise 66
[copy\(\)](#) 156
[Copyable](#), concept 158
[CopyConstructible](#), concept 158
[copy_if\(\)](#) 156
 Core Guidelines, C++ 214
 core language, C++ 2
 coroutine 211
[cos\(\)](#) 188

[cosh\(\)](#) 188
 cost
 of copy 70
 of range checking 142
[count\(\)](#) 156
[count_if\(\)](#) 155–156
[cout](#), output 3
[<cstdlib>](#) 110
 C-style
 error handling 188
 string 13

D

[\D](#), [regex](#) 119
[\d](#), [regex](#) 119
[d](#), [regex](#) 119
 data race 196
[data\(\)](#), [array](#) 171
 D&E 208
 deadlock 199
 deallocation 51
 debugging [template](#) 100
 declaration 5
 function 4
 in condition 61
 interface 29
 -declaration, [using](#) 34
 declarator operator 12
[decltype](#) 215
 decrement operator -- 7
 deduction
 guide 83, 176
 [return](#)-type 44
 default
 constructor 50
 function argument 42
 member initializer 68
 operations 66
 [template](#) argument 98
[=default](#) 66
[DefaultConstructible](#), concept 158
 definition
 implementation 30
 of concepts 97
 delegating constructor 215
[=delete](#) 67
[delete](#)
 naked 52
 operator 51
 deprecated
 [auto_ptr](#) 218
 feature 218
[deque](#) 146
 derived [class](#), base and 55
[DerivedFrom](#), concept 158

Destructible, concept 158
 destructor 51, 66
 ~ 51
 constructor and 210
 virtual 59
 dictionary – see **map**
 difference
 from C 218
 from C **void*** assignment 221
 digit, **[[:digit:]]** 119
digit, regex 119
[[:digit:]] digit 119
 -directive, **using** 35
 dispatch, tag 181
 distribution, **random** 191
 divide operator / 6
 domain error 188
double 5
 duck typing 104
duration 179
duration_cast 179
 dynamic store 51
dynamic_cast 61
 is instance of 62
 is kind of 62

E

EDOM 188
 element requirements 140
 elision, copy 66
emplace_back() 147
empty() 147
enable_if 184
 encapsulation, complete 66
end() 75, 143, 147, 150
 engine, **random** 191
enum, bitset and 172
 equal operator == 6
 equality preserving 159
EqualityComparable, concept 158
equal_range() 156, 173
ERANGE 188
erase() 143, 147
errno 188
 error
 domain 188
 handling 35
 handling, C-style 188
 range 188
 recovery 38
 run-time 35
 error-code, exception vs 38
 essential operations 66
 evaluation
 compile-time 10

 order of 7
 example
 find_all() 151
 Hello, World! 2
 Rand_int 191
 Vec 141
 exception 35
 and **main()** 141
 catch every 141
 specification, removed 218
 vs error-code 38
exclusive_scan() 189
 execution policy 161
 explicit type conversion 53
explicit constructor 67
exponential_distribution 191
export removed 218
expr() 188
 expression
 constant 10
 lambda 87
 requires] 96
extern template 215

F

fabs() 188
 facilities, standard library 108
fail_fast 170
 feature, deprecated 218
 features
 C with Classes language 210
 C++11 language 215
 C++14 language 216
 C++17 language 216
 file, header 31
final 216
find() 150, 156
find_all() example 151
find_if() 155–156
first, pair member 173
floor() 188
fmod() 188
for
 statement 11
 statement, range 11
forward() 167
 forwarding, perfect 168
ForwardIterator, concept 159
forward_list 146
 singly-linked list 143
<forward_list> 109
ForwardRange, concept 160
 free store 51
frexp() 188
<fstream> 109

`__func__` 215
 function 2
 and code complexity 4
 argument 41
 argument, default 42
 argument passing 66
 body 2
 body, `try` block as 141
 `const` member 50
 `constexpr` 10
 declaration 4
 implementation of `virtual` 56
 mathematical 188
 object 85
 overloading 4
 return value 41
 `template` 84
 type 181
 value return 66
 function 180
 and `nullptr` 180
 fundamental type 5
 future
 and `promise` 202
 member `get()` 202
 <future> 109, 202

G

garbage collection 73
 generic programming 93, 210
`get->()`
 by index 174
 by type 174
`get()`, `future` member 202
 graph, `regex` 119
 greater-than operator > 6
 greater-than-or-equal operator >= 6
 greedy match 118, 121
 grouping, {} 2
 gsl
 namespace 168
 span 168
 Guidelines, C++ Core 214

H

half-open sequence 156
 handle 52
 resource 69, 165
 hardware, mapping to 16
 hash table 144
`hash<>`, `unordered_map` 76
 header
 C-library 110

file 31
 standard library 109
 heap 51
 Hello, World! example 2
 hierarchy
 class 57
 navigation 61
 history, C++ 207
 HOPL 208

I

`if` statement 14
 immutability
 `const` 9
 `constexpr` 9
 implementation
 definition 30
 inheritance 60
 iterator 153
 of `virtual` function 56
 string 113
 in-class member initialization 215
 #include 31
`inclusive_scan()` 189
 increment operator ++ 7
 index, `get->()` by 174
 inheritance 55
 implementation 60
 interface 60
 multiple 211
 inheriting constructor 216
 initialization
 and assignment 18
 in-class member 215
 initialize 52
 array 171
 initializer
 = 7
 {} 8
 default member 68
 narrowing, = 8
 initializer-list constructor 52
`initializer_list` 52
 inline 49
 namespace 215
 inlining 49
`inner_product()` 189
`InputIterator`, concept 159
`InputRange`, concept 160
`insert()` 143, 147
 instantiation 81
 instruction, machine 16
`int` 5
 output bits of 172
`Integral`, concept 158

interface
 declaration 29
 inheritance 60

invariant 37
 and constructor 37

[Invocable](#), concept 159

[InvocableRegular](#), concept 159

I/O, iterator and 154

`<ios>` 109

`<iostream>` 3, 109

`iota()` 189

is
 instance of, [dynamic_cast](#) 62
 kind of, [dynamic_cast](#) 62

ISO
 C++ 212
 C++ standard 2

ISO-14882 212

[istream_iterator](#) 154

iterator 75, 150
 and I/O 154
 implementation 153

[Iterator](#), concept 159

`iterator` 143, 154

`<iterator>` 182
 concepts in 158

[iterator_category](#) 182

[iterator_traits](#) 181–182

[iterator_type](#) 182

J

[join\(\)](#), [thread](#) 196

K

key and value 144

K&R C 219

L

`\L`, [regex](#) 119

`\l`, [regex](#) 119

lambda
 as adaptor 180
 expression 87

language
 and library 107
 features, C with Classes 210
 features, C++11 215
 features, C++14 216
 features, C++17 216

launch, [async\(\)](#) 204

lazy
 +? 118

?? 118
 {}? 118
 *? 118
 match 118, 121

`ldexp()` 188

leak, resource 62, 72, 164

less-than operator < 6

less-than-or-equal operator <= 6

letter, [\[\[alpha:\]\]](#) 119

library
 algorithm, standard 156
 C with Classes standard 211
 C++98 standard 211
 components, C++11 216
 components, C++14 217
 components, C++17 217
 container, standard 146
 facilities, standard 108
 language and 107
 non-standard 107
 standard 107

lifetime, scope and 9

lifting algorithm 100

`<limits>` 181, 193

linker 2

list
 capture 87
[forward_list](#) singly-linked 143

`list` 142, 146

literal
 ", string 3
 raw string 116
 suffix, [s](#) 113
 suffix, [sv](#) 115
 type of string 113
 user-defined 75, 215

[literals](#)
[string_literals](#) 113
[string_view_literals](#) 115

local scope 9

lock, reader-writer 200

`log()` 188

`log10()` 188

long long 215

[lower](#), [regex](#) 119

M

machine instruction 16

`main()` 2
 exception and 141

[make_pair\(\)](#) 173

[make_shared\(\)](#) 166

[make_tuple\(\)](#) 174

[make_unique\(\)](#) 166

management, resource 72, 164

map 144, 146
 and **unordered_map** 146
<map> 109
 mapped type, value 144
 mapping to hardware 16
 match
 greedy 118, 121
 lazy 118, 121
 mathematical
 function 188
 functions, special 188
 functions, standard 188
<math.h> 188
 Max Munch rule 118
 meaning, C++ 209
 member
 function, **const** 50
 initialization, in-class 215
 initializer, default 68
 memberwise copy 66
mem_fn() 180
 memory 73
 address 16
<memory> 109, 164, 166
merge() 156
Mergeable, concept 159
 minus operator - 6
 model, **template** compilation 104
 modern C++ 214
modf() 188
 modularity 29
module support 32
 modules, C++20 32
 modulus operator % 6
Movable, concept 158
 move 71
 assignment 66, 72
 constructor 66, 71
move() 72, 156, 167
MoveConstructible, concept 158
 moved-from
 object 72
 state 168
 move-only type 167
 multi-line pattern 117
multimap 146
 multiple
 character sets 114
 inheritance 211
 return-values 44
 multiply operator * 6
multiset 146
mutex 199
<mutex> 199

N

\n, newline 3
 naked
 delete 52
 new 52
 namespace scope 9
namespace 34
 chrono 179
 gsl 168
 inline 215
 pmr 178
 std 3, 35, 109
 narrowing
 = initializer 8
 conversion 8
 navigation, hierarchy 61
new
 container allocator 178
 naked 52
 operator 51
 newline **\n** 3
noexcept 37
noexcept() 215
 non-memory resource 73
 non-standard library 107
noreturn 215
normal_distribution 191
 notation, regular expression 117
 not-equal operator != 6
notify_one(), **condition_variable** 202
NULL, **0**, **nullptr** 13
nullptr 13
 function and 180
 NULL 0 13
 number, random 191
<numeric> 189
 numerical algorithm 189
numeric_limits 193

O

object 5
 function 85
 in container 140
 moved-from 72
 object-oriented programming 57, 210
 operations
 default 66
 essential 66
 operator
 %= 7
 += 7
 &, address-of 11
 (), call 85
 *, contents-of 11

- , decrement 7
- /, divide 6
- ==, equal 6
- >, greater-than 6
- >=, greater-than-or-equal 6
- ++, increment 7
- <, less-than 6
- <=, less-than-or-equal 6
- , minus 6
- %, modulus 6
- *, multiply 6
- !=, not-equal 6
- <<, output 3
- +, plus 6
- %, remainder 6
- /=, scaling 7
- *=, scaling 7
- arithmetic 6
- comparison 6, 74
- declarator 12
- delete 51
- new 51
- overloaded 51
- user-defined 51
- optimization, short-string 113
- optional 176
- order of evaluation 7
- ostream_iterator 154
- out_of_range 141
- output
 - bits of int 172
 - cout 3
 - operator << 3
- OutputIterator, concept 159
- OutputRange, concept 160
- overloaded operator 51
- overloading
 - concept based 95
 - function 4
- override 55
- overview, container 146
- ownership 164

P

- packaged_task thread 203
- pair 173
 - and structured binding 174
 - member first 173
 - member second 173
- par 161
- parallel algorithm 161
- parameterized type 79
- partial_sum() 189
- par_unseq 161
- passing data to task 197

- pattern 116
 - (?: 120
 - multi-line 117
- perfect forwarding 168
- Permutable, concept 159
- phone_book example 138
- plus operator + 6
- pmr, namespace 178
- pointer 17
 - smart 164
 - to * 11
- policy, execution 161
- polymorphic type 54
- pow() 188
- precondition 37
- predicate 86, 155
 - type 183
- Predicate, concept 159
- print, regex 119
- procedural programming 2
- program 2
- programming
 - generic 93, 210
 - object-oriented 57, 210
 - procedural 2
- promise
 - future and 202
 - member set_exception() 202
 - member set_value() 202
- pronunciation, C++ 209
- punct, regex 119
- pure virtual 54
- purpose, template 93
- push_back() 52, 139, 143, 147
- push_front() 143

R

- R" 116
- race, data 196
- RAII
 - and resource management 36
 - and try-block 40
 - and try-statement 36
 - resource acquisition 164
 - scoped_lock and 199–200
- RAII 52
- Rand_int example 191
- random number 191
- random
 - distribution 191
 - engine 191
 - <random> 109, 191
- RandomAccessIterator, concept 159
- RandomAccessRange, concept 160
- range

- checking, cost of 142
- checking **Vec** 140
- error 188
- for statement 11
- Range**
 - concept 157
 - concept 160
- <ranges> 157
- <ranges>, concepts in 158
- raw string literal 116
- reader-writer lock 200
- recovery, error 38
- reduce()** 189
- reference 17
 - &&, rvalue 71
 - rvalue 72
 - to & 12
- regex**
 - * 117
 - } 117
 - { 117
 -) 117
 - | 117
 -] 117
 - [117
 - ^ 117
 - ? 117
 - .
 - \$ 117
 - + 117
 - (117
 - alnum 119
 - alpha 119
 - blank 119
 - cntrl 119
 - d 119
 - \d 119
 - \D 119
 - digit 119
 - graph 119
 - \l 119
 - \L 119
 - lower 119
 - print 119
 - punct 119
 - regular expression 116
 - repetition 118
 - s 119
 - \S 119
 - \s 119
 - space 119
 - \U 119
 - \u 119
 - upper 119
 - w 119
 - \W 119
 - \w 119
 - xdigit 119
- <regex> 109, 116
 - regular expression 116
- regex_iterator** 121
- regex_search** 116
- regular**
 - expression notation 117
 - expression **regex** 116
 - expression <**regex**> 116
- Regular**, concept 158
- reinterpret_cast** 53
- Relation**, concept 159
- remainder operator % 6
- removed
 - exception specification 218
 - export 218
- repetition, **regex** 118
- replace()** 156
 - string 112
- replace_if()** 156
- requirement, **template** 94
- requirements, element 140
- requires] expression 96
- reserve()** 139, 147
- resize()** 147
- resource**
 - acquisition RAI 164
 - handle 69, 165
 - leak 62, 72, 164
 - management 72, 164
 - management, RAI and 36
 - non-memory 73
 - retention 73
 - safety 72
- rethrow 38
- return**
 - function value 66
 - type, suffix 215
 - value, function 41
- return**
 - container 151
 - type, **void** 3
- returning results from task 198
- return-type** deduction 44
- return-values, multiple 44
- riemannzeta()** 188
- rule**
 - Max Munch 118
 - of zero 67
- run-time**
 - check 40
 - error 35
- rvalue**
 - reference 72
 - reference && 71

S

- s literal suffix 113
- `\s, regex` 119
- `s, regex` 119
- `\S, regex` 119
- safety, resource 72
- `Same`, concept 158
- scaling
 - operator `/=` 7
 - operator `*=` 7
- scope
 - and lifetime 9
 - `class` 9
 - local 9
 - namespace 9
- `scoped_lock` 164
 - and RAII 199–200
 - `unique_lock` and 201
- `scoped_lock()` 199
- search, binary 156
- `second, pair` member 173
- `Semiregular`, concept 158
- `Sentinel`, concept 159
- separate compilation 30
- sequence 150
 - half-open 156
- `set` 146
- `<set>` 109
- `set_exception()`, `promise` member 202
- `set_value()`, `promise` member 202
- `shared_lock` 200
- `shared_mutex` 200
- `shared_ptr` 164
- sharing data task 199
- short-string optimization 113
- `SignedIntegral`, concept 158
- SIMD 161
- `Simula` 207
- `sin()` 188
- singly-linked list, `forward_list` 143
- `sinh()` 188
- size of type 6
- `size()` 75, 147
 - `array` 171
- `SizedRange`, concept 160
- `SizedSentinel`, concept 159
- `sizeof` 6
- `sizeof()` 181
- `size_t` 90
- smart pointer 164
- `smatch` 116
- `sort()` 149, 156
 - container 181
- `Sortable`, concept 159
- `space, regex` 119
- `span`
 - `gsl` 168
 - `string_view` and 168
- special mathematical functions 188
- specialized container 170
- `sphbessel()` 188
- `sqrt()` 188
- `<sstream>` 109
- standard
 - ISO C++ 2
 - library 107
 - library algorithm 156
 - library, C++ 2
 - library, C with Classes 211
 - library, C++98 211
 - library container 146
 - library facilities 108
 - library header 109
 - library `std` 109
 - mathematical functions 188
- standardization, C++ 212
- state, moved-from 168
- statement
 - `for` 11
 - `if` 14
 - `range for` 11
 - `switch` 14
 - `while` 14
- `static_assert` 193
 - assertion 40
- `static_cast` 53
- `std`
 - `namespace` 3, 35, 109
 - standard library 109
- `<stdexcept>` 109
- STL 211
- store
 - dynamic 51
 - free 51
- `StrictTotallyOrdered`, concept 158
- `StrictWeakOrder`, concept 159
- string
 - C-style 13
 - literal `"` 3
 - literal, raw 116
 - literal, type of 113
 - Unicode 114
- `string` 111
 - `[]` 112
 - `==` 112
 - `append +=` 112
 - `assignment =` 112
 - `concatenation +` 111
 - `implementation` 113
 - `replace()` 112
 - `substr()` 112
- `<string>` 109, 111

- [string_literals, literals](#) 113
- [string_span](#) 170
- [string_view](#) 114
 - and [span](#) 168
- [string_view_literals, literals](#) 115
- structured
 - binding 45
 - binding, [pair](#) and 174
 - binding, [tuple](#) and 174
- subclass, superclass and 55
- [\[\]](#) subscripting 147
- [substr\(\), string](#) 112
- suffix 75
 - return type 215
 - [s](#) literal 113
 - [sv](#) literal 115
- superclass and subclass 55
- support, [module](#) 32
- support, concept 94
- [sv](#) literal suffix 115
- [swap\(\)](#) 76
- [Swappable](#), concept 158
- [SwappableWith](#), concept 158
- [switch](#) statement 14
- [synchronized_pool_resource](#) 178

T

- table, hash 144
- tag dispatch 181
- [tanh\(\)](#) 188
- task
 - and [thread](#) 196
 - communication 202
 - passing data to 197
 - returning results from 198
 - sharing data 199
- TC++PL 208
- [template](#) 79
 - alias 184
 - argument, constrained 82
 - argument, default 98
 - arguments, [>>](#) 215
 - [class](#) 79
 - compilation model 104
 - constrained 82
 - debugging 100
 - [extern](#) 215
 - function 84
 - purpose 93
 - requirement 94
 - variadic 100
- [this](#) 70
- [thread](#)
 - [join\(\)](#) 196
 - [packaged_task](#) 203

- task and 196
- [<thread>](#) 109, 196
- [thread_local](#) 216
- time 179
- timeline, C++ 208
- [time_point](#) 179
- timing, [clock](#) 200
- to hardware, mapping 16
- [transform_reduce\(\)](#) 189
- translation unit 32
- [try](#)
 - block 36
 - block as function body 141
- [try-block, RAI](#) and 40
- [try-statement, RAI](#) and 36
- [tuple](#) 174
 - and structured binding 174
- type 5
 - abstract 54
 - argument 82
 - concrete 48
 - conversion, explicit 53
 - function 181
 - fundamental 5
 - [get-<>\(\)](#) by 174
 - move-only 167
 - of string literal 113
 - parameterized 79
 - polymorphic 54
 - predicate 183
 - size of 6
- [typename](#) 79, 152
- [<type_traits>](#) 183
- typing, duck 104

U

- [\U, regex](#) 119
- [\u, regex](#) 119
- udl 75
- Unicode string 114
- [uniform_int_distribution](#) 191
- uninitialized 8
- [unique_copy\(\)](#) 149, 156
- [unique_lock](#) 200–201
 - and [scoped_lock](#) 201
- [unique_ptr](#) 62, 164
- [unordered_map](#) 144, 146
 - [hash<>](#) 76
 - [map](#) and 146
- [<unordered_map>](#) 109
- [unordered_multimap](#) 146
- [unordered_multiset](#) 146
- [unordered_set](#) 146
- unsigned 5
- [UnsignedIntegral](#), concept 158

[upper, regex](#) 119
 use, concept 94
 user-defined
 literal 75, 215
 operator 51
[using](#)
 alias 90
 -declaration 34
 -directive 35
 usual arithmetic conversions 7
[<utility>](#) 109, 173–174

V

[valarray](#) 192
[<valarray>](#) 192
 value 5
 argument 82
 key and 144
 mapped type 144
 return, function 66
[decltype](#) 147
[value_type](#) 90
 variable 5
 variadic [template](#) 100
[variant](#) 175
[Vec](#)
 example 141
 range checking 140
 vector arithmetic 192
[vector](#) 138, 146
 array vs. 171
[<vector>](#) 109
[vector<bool>](#) 170
 vectorized 161
[View](#), concept 160
[virtual](#) 54
 destructor 59
 function, implementation of 56
 function table [vtbl](#) 56
 pure 54
[void](#)
 * 221
 * assignment, difference from C 221
 return type 3
[vtbl](#), [virtual](#) function table 56

W

[w, regex](#) 119
[\w, regex](#) 119
[\W, regex](#) 119
[wait\(\)](#), [condition_variable](#) 201
[WeaklyEqualityComparable](#), concept 158
 WG21 208

[while](#) statement 14

X

[X3J16](#) 212
[xdigit, regex](#) 119

Z

zero, rule of 67

This page intentionally left blank

More Guidance from the Inventor of C++

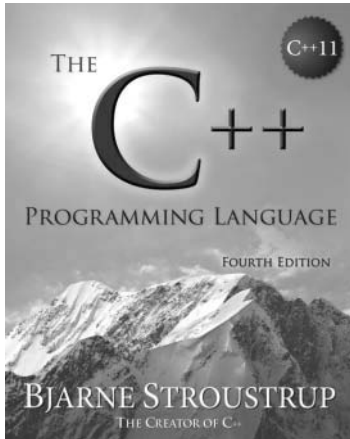

The C++ Programming Language, Fourth Edition, delivers meticulous, richly explained, and integrated coverage of the entire language—its facilities, abstraction mechanisms, standard libraries, and key design techniques. Throughout, Stroustrup presents concise, “pure C++ 11” examples, which have been carefully crafted to clarify both usage and program design.

Available in soft cover, hard cover, and eBook formats.

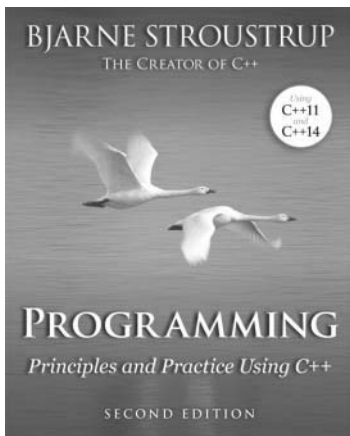

Programming: Principles and Practice Using C++, Second Edition, is a general introduction to programming, including object-oriented and generic programming, and a solid introduction to the C++ language. Stroustrup presents modern C++ techniques from the start, introducing the C++ standard library to simplify programming tasks.

Available in soft cover with lay-flat spine and eBook formats.

informit.com/stroustrup

 Pearson
Addison-Wesley

informIT.com
the trusted technology learning source

<https://t.me/learningnets>