

- STP Toolkit
 - PortFast
 - Allows switch ports connected to end hosts to immediately enter the STP Forwarding state, bypassing Listening and Learning.
 - BPDU Guard
 - Automatically disables a port if it receives a BPDU, protecting the STP topology by preventing unauthorized devices from becoming part of the network.
 - BPDU Filter
 - Stops a port from sending BPDUs or processing received BPDUs.
 - Root Guard
 - Prevents a port from becoming a Root Port by disabling it if superior BPDUs are received, thereby enforcing the current Root Bridge.
 - **Loop Guard – this video**
 - Protects the network from loops by disabling a port if it unexpectedly stops receiving BPDUs, ensuring it does not mistakenly enter the Forwarding state.

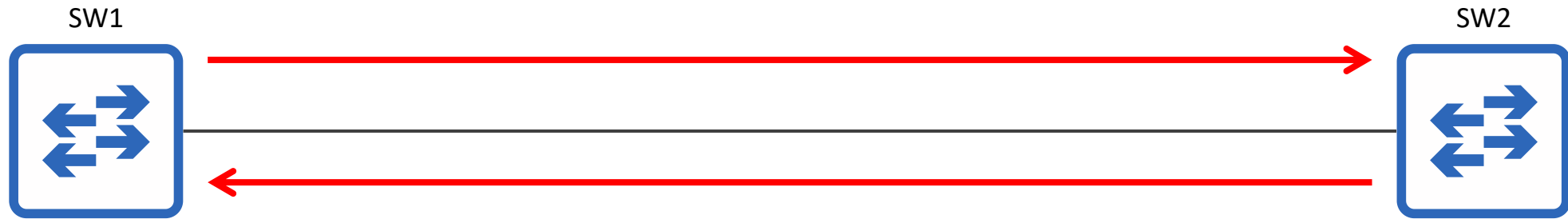



- A **unidirectional link** is a network link where data transmission occurs in only one direction.
 - e.g. SW1 can send frames to SW2, but SW2 can't send frames to SW1.
- Unidirectional links are typically caused by Layer 1 (Physical) issues.
 - Damaged cables
 - Faulty connectors or transceivers (e.g. SFP modules)
- Unidirectional links are more common with fiber-optic cables than copper UTP.

Unidirectional links

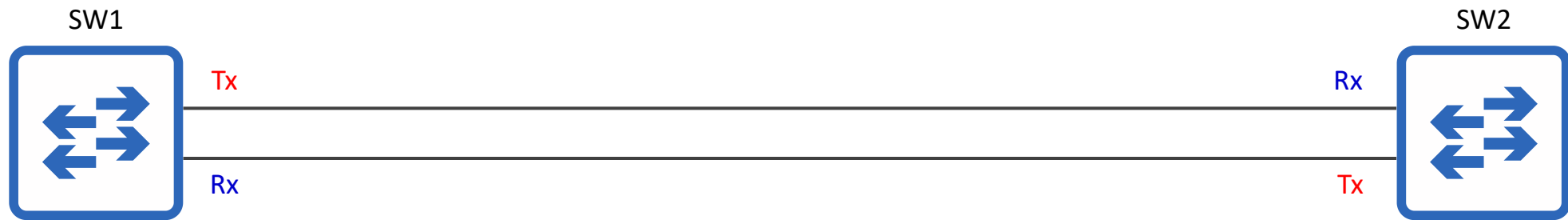

- A **unidirectional link** is a network link where data transmission occurs in only one direction.
 - e.g. SW1 can send frames to SW2, but SW2 can't send frames to SW1.
- Unidirectional links are typically caused by Layer 1 (Physical) issues.
 - Damaged cables
 - Faulty connectors or transceivers (e.g. SFP modules)
- Unidirectional links are more common with fiber-optic cables than copper UTP.
 - Fiber optic connections typically use two separate fibers.
 - If one fiber is damaged, it can disrupt data flow in one direction while the other remains unaffected.
 - More vulnerable to physical damage than copper UTP cables.

Unidirectional links

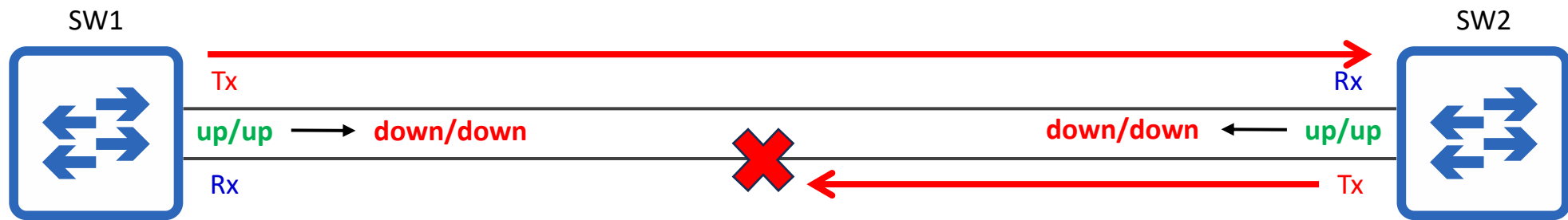

- For a fiber-optic interface to be **up/up**, both fibers must be connected and functional.
- If there is a physical problem with either fiber, the devices should be able to detect it and disable their interfaces.
- If the devices fail to detect the physical problem, it could result in a **unidirectional link**.

Loop Guard – the problem

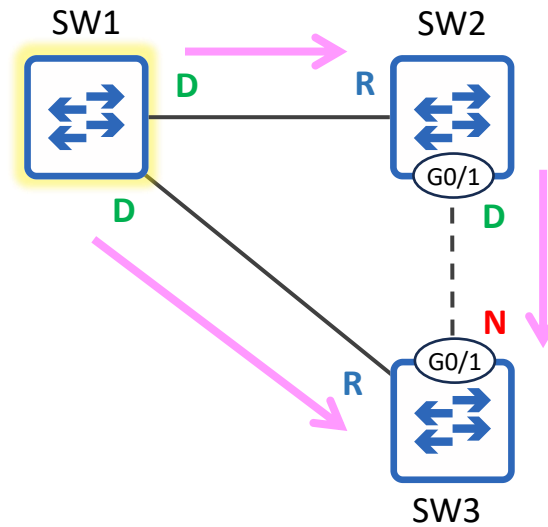

- BPDUs originate from the Root bridge and are forwarded out of Designated ports.
- SW3 G0/1 is a **Non-Designated** blocking port because it receives superior BPDUs from SW2.
 - i.e. SW2 has a superior root cost or bridge ID

Loop Guard – the problem

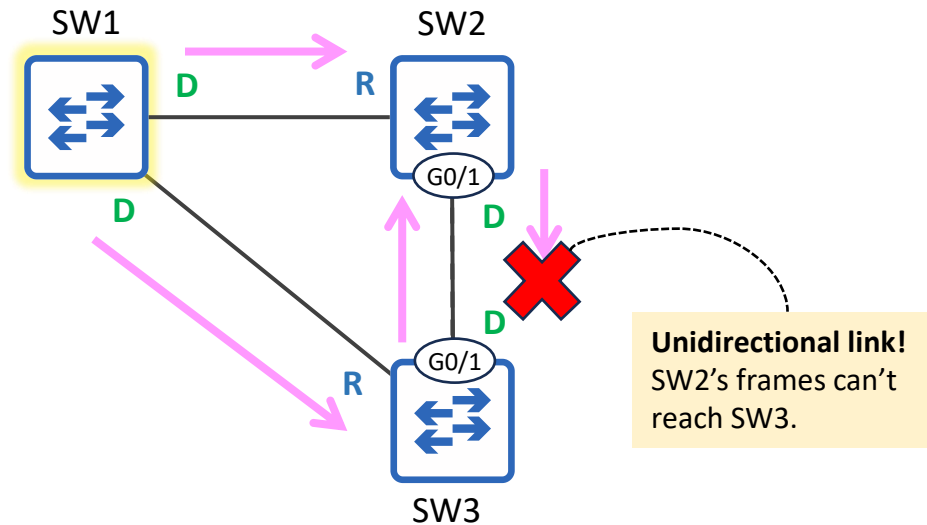

- BPDUs originate from the Root bridge and are forwarded out of Designated ports.
- SW3 G0/1 is a **Non-Designated** blocking port because it receives superior BPDUs from SW2.
 - i.e. SW2 has a superior root cost or bridge ID
- If the SW2-SW3 link becomes unidirectional and SW2's BPDUs can't reach SW3, what will happen?
 - SW3 G0/1 will become a **Designated** port and start forwarding BPDUs.
- Because SW3's BPDUs are inferior to SW2's, SW2 simply ignores SW3's BPDUs.
 - SW2 G0/1 and SW3 G0/1 are both in the forwarding state.
 - **SW1-SW3-SW2 loop!**

Loop Guard – the problem

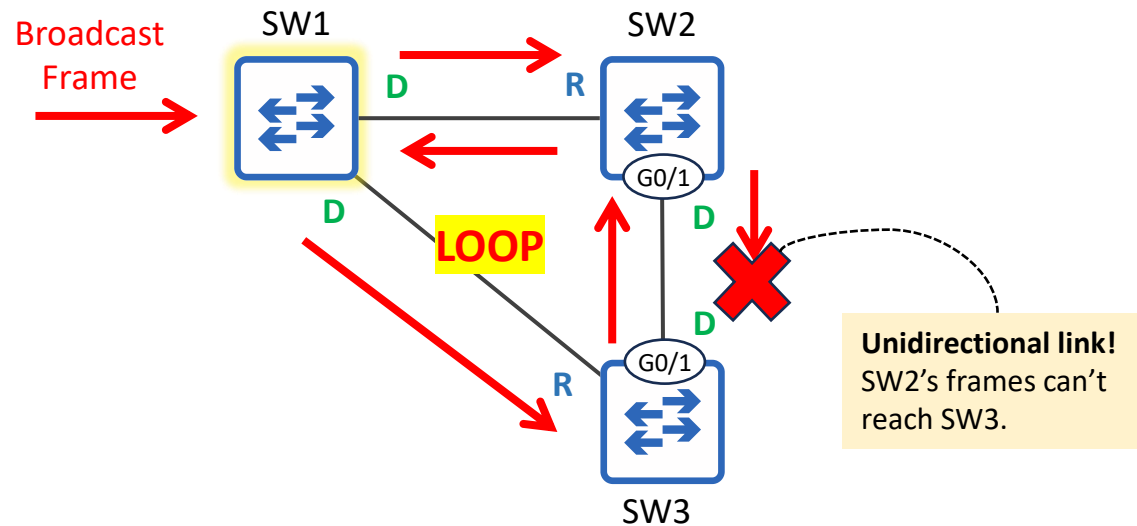

- BPDUs originate from the Root bridge and are forwarded out of Designated ports.
- SW3 G0/1 is a **Non-Designated** blocking port because it receives superior BPDUs from SW2.
 - i.e. SW2 has a superior root cost or bridge ID
- If the SW2-SW3 link becomes unidirectional and SW2's BPDUs can't reach SW3, what will happen?
 - SW3 G0/1 will become a **Designated** port and start forwarding BPDUs.
- Because SW3's BPDUs are inferior to SW2's, SW2 simply ignores SW3's BPDUs.
 - SW2 G0/1 and SW3 G0/1 are both in the forwarding state.
 - **SW1-SW3-SW2 loop!**

Loop Guard – the solution

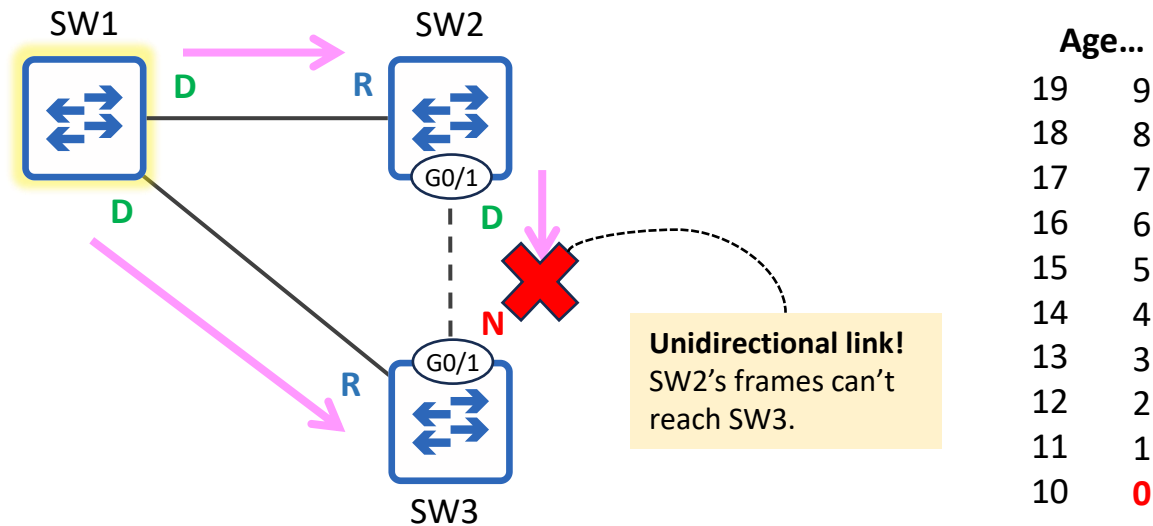

- When a **Loop Guard**-enabled port's Max Age timer counts down to 0, it doesn't become a Designated port and start transitioning to Forwarding.
 - It enters the **Broken (Loop Inconsistent)** state.
 - Like the **Broken (Root Inconsistent)** state triggered by a Root Guard violation, this blocks the port.
 - *NOTE: In both cases, the port remains **up/up**, but STP blocks it.*
- If the broken port starts receiving BPDUs again, it will be automatically re-enabled.
- Loop Guard can be enabled in two ways:
 - Per-port: SW3(config-if)# **spanning-tree guard loop**
 - Default: SW3(config)# **spanning-tree loopguard default**
 - This enables Loop Guard on all ports
 - Use SW3(config-if)# **spanning-tree guard none** to disable it on specific ports if needed.

Loop Guard should be enabled on Root and Non-Designated ports (ports that are supposed to receive BPDUs).

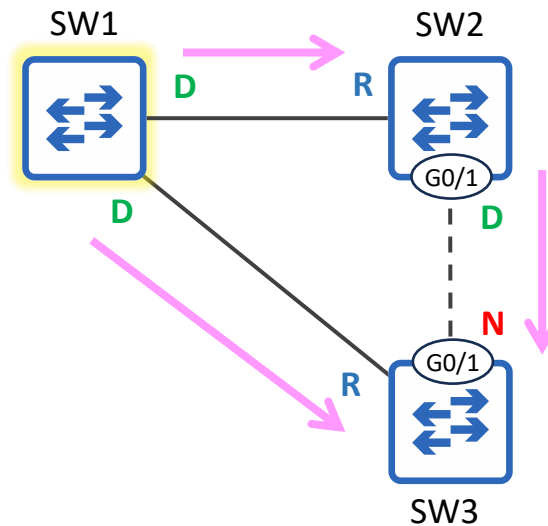

```

SW3(config)# interface g0/1
SW3(config-if)# spanning-tree guard loop
SW3(config-if)# do show spanning-tree interface g0/1 detail
Port 2 (GigabitEthernet0/1) of VLAN0001 is alternate blocking
  Port path cost 4, Port priority 128, Port Identifier 128.2.
  Designated root has priority 1, address 5254.001a.9d29
  Designated bridge has priority 28673, address 5254.0019.f184
  Designated port id is 128.2, designated path cost 4
  Timers: message age 3, forward delay 0, hold 0
  Number of transitions to forwarding state: 0
  Link type is point-to-point by default
  Loop guard is enabled on the port
  BPDU: sent 0, received 359
  
```

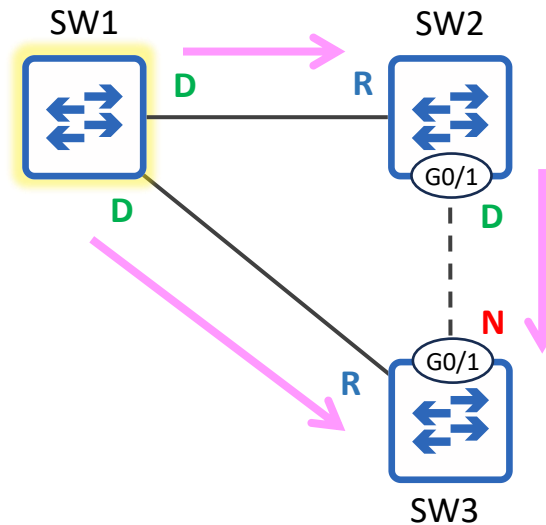

```

SW3(config)# spanning-tree loopguard default
SW3(config)# do show spanning-tree interface g0/1 detail
Port 2 (GigabitEthernet0/1) of VLAN0001 is alternate blocking
Port path cost 4, Port priority 128, Port Identifier 128.2.
Designated root has priority 1, address 5254.001a.9d29
Designated bridge has priority 28673, address 5254.0019.f184
Designated port id is 128.2, designated path cost 4
Timers: message age 3, forward delay 0, hold 0
Number of transitions to forwarding state: 0
Link type is point-to-point by default
Loop guard is enabled on the port by default
BPDU: sent 0, received 359
  
```

Loop Guard: CLI demonstration

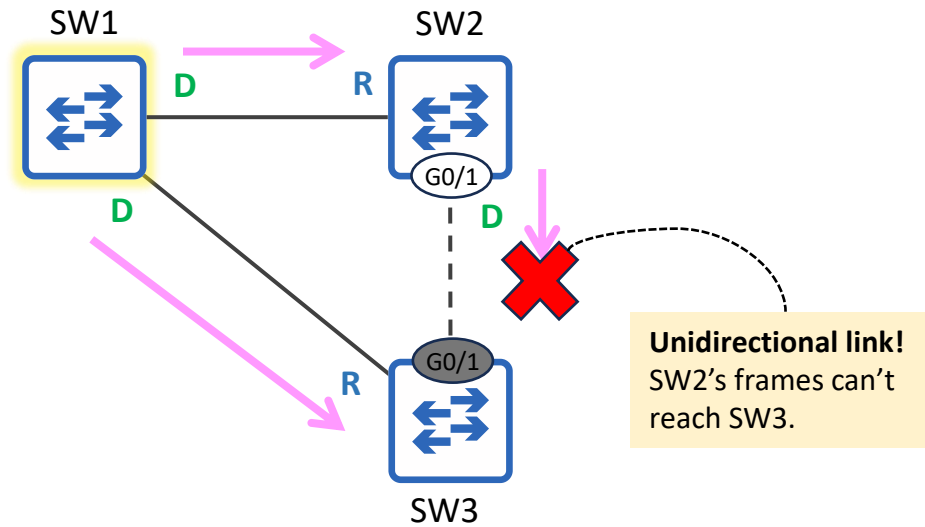

```
%SPANTREE-2-LOOPGUARD_BLOCK: Loop guard blocking port GigabitEthernet0/1 on VLAN0001.
```

```
SW3(config-if)# do show spanning-tree
```

```
!output omitted
```

Interface	Role	Sts	Cost	Prio.Nbr	Type
-----	-----	-----	-----	-----	-----
Gi0/0	Root	FWD	4	128.1	P2p
Gi0/1	Desg	BKN*4		128.2	P2p *LOOP_Inc

BKN = Broken
LOOP_Inc = Loop Inconsistent

Loop Guard: CLI demonstration

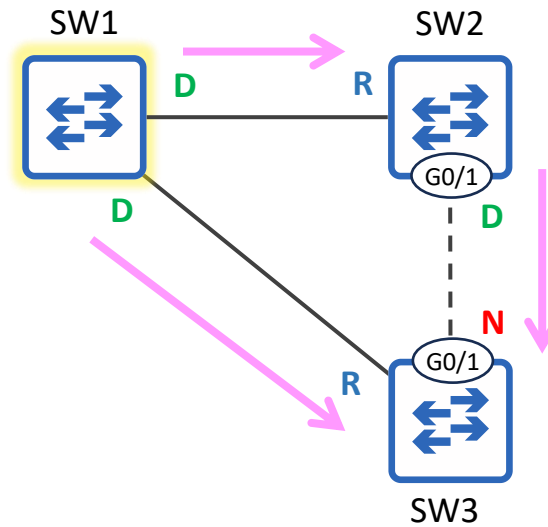

```
%SPANTREE-2-LOOPGUARD_UNBLOCK: Loop guard unblocking port GigabitEthernet0/1 on VLAN0001.
```

```
SW3(config-if)# do show spanning-tree
```

```
!output omitted
```

Interface	Role	Sts	Cost	Prio.Nbr	Type
Gi0/0	Root	FWD	4	128.1	P2p
Gi0/1	Altn	BLK	4	128.2	P2p

Loop Guard & Root Guard

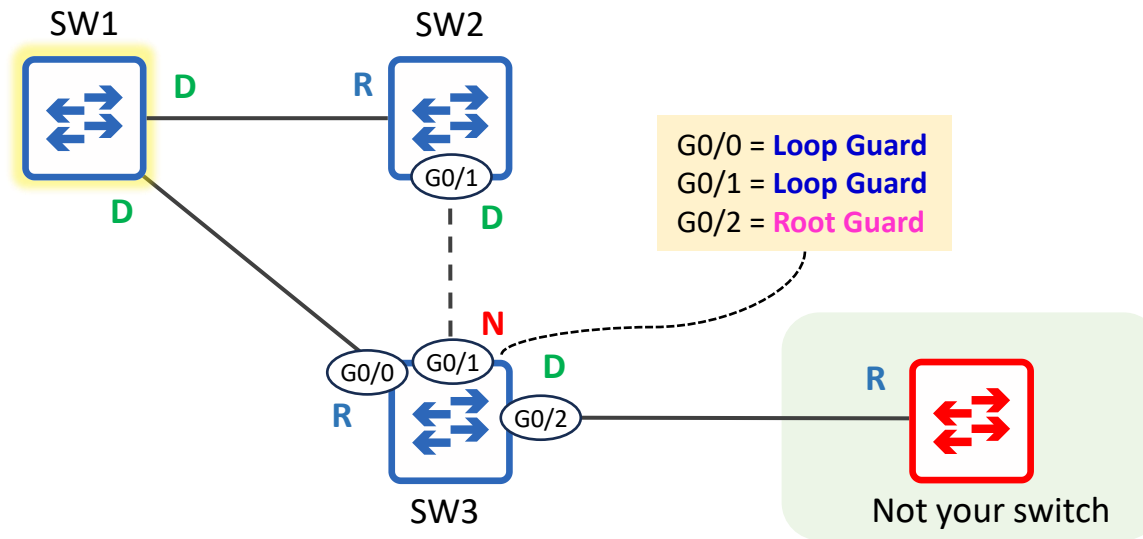

- **Loop Guard** and **Root Guard** are mutually exclusive.
 - They can't be enabled on the same port at the same time.
 - **Root Guard** is meant to prevent Designated ports from becoming Root ports.
 - **Loop Guard** is meant to prevent Non-Designated or Root ports from becoming Designated ports.
- If Loop Guard is configured on a port (**spanning-tree guard loop**) and you then configure Root Guard (**spanning-tree guard root**), Loop Guard will be disabled on the port.
 - and vice-versa
- If Loop Guard is enabled by default (**spanning-tree loopguard default**) and you then configure Root Guard on a port, Loop Guard will be disabled on the port.
 - The more specific configuration (interface vs global) takes effect.

- **Loop Guard** protects the network from loops by blocking a port if it unexpectedly stops receiving BPDUs.
 - A software bug preventing a switch from sending BPDUs
 - A hardware issue causing a unidirectional link.
- A **unidirectional link** is a network link where data transmission occurs in only one direction.
 - Typically caused by Layer 1 issues on fiber-optic cables.
 - If the connected devices don't detect the issue and disable their interfaces, it can result in a unidirectional link.
 - If a Root or Non-Designated port stops receiving BPDUs, it will become a Designated port, potentially causing a Layer 2 loop.
- If a **Loop Guard**-enabled port stops receiving BPDUs, it enters the **Broken** (*Loop Inconsistent*) state, effectively disabling the port.
 - If it starts receiving BPDUs again, it will be automatically re-enabled.
- Loop Guard can be enabled in two ways:
 - Per-port: SW3(config-if)# **spanning-tree guard loop**
 - Default: SW3(config)# **spanning-tree loopguard default**
 - This enables Loop Guard on all ports
 - Use SW3(config-if)# **spanning-tree guard none** to disable it on specific ports if needed.
- **Loop Guard** and **Root Guard** are mutually exclusive.
 - If Loop Guard is configured on a port and you then configure Root Guard, Loop Guard will be disabled on the port (and vice-versa).
 - If Loop Guard is enabled by default (**spanning-tree loopguard default**) and you then configure Root Guard on a port, Loop Guard will be disabled on the port.