

Design Document for
“Introduction to Cisco Data
Centers Technologies (DCICT)
v1.0”

Document Sections

The Design Document includes these topics:

- Document Purpose
- Product Information
 - Project Description
 - Course Description
 - Curricula
 - Delivery Types
 - Deliverables
 - Target Audiences
 - Target Theaters and Locales
 - Prerequisite Skills and Knowledge
 - Course Evaluation
 - Assessment Strategy
 - Assumptions and Risks
- High-Level Course Design
 - Course Goal
 - Job Tasks and Domain and Skill Objectives
 - Course Flow Diagram
 - Course Structure and Objectives
 - Delivery Specifications
 - Supporting Personnel
 - Required Classroom Reference Materials
 - Required Classroom Environment
 - Instructor Certification Requirements
 - Laboratory Topology (Delivery)
 - General Information
 - Overall Lab Description
 - Development Lab Equipment Requirements
- Detailed Course Design
 - Module 0 of 5: Course Introduction
 - Module 1 of 5: Cisco Data Center Network Services
 - Module 2 of 5: Cisco Data Center Virtualization
 - Module 3 of 5: Cisco Data Center Storage Networking
 - Module 4 of 5: Cisco Data Center Unified Fabric
 - Module 5 of 5: Cisco Unified Computing System

Document Purpose

The purpose of this document is to provide project personnel with the high-level information and design of the development project and specifications for the design of the course or learning product.

Product Information

The two Introduction to Cisco Data Centers courses, DCICN and DCICT (working titles), will prepare the learner for a CCNA Data Center exam certification. They will cover the Data Center Cisco technologies, including Unified Computing, virtualization, Unified Fabric (Nexus product family) and Storage Networking. Interworking with Catalyst 6500 and non-Cisco products for the virtualization of the computing environment will also be covered. The courses will be partitioned in the most effective way to reflect the need to onboard a variety of learners who may be specialized in some of the Data Center technologies, but who need to be able to perform in a broader role. For example, a compute or storage expert may need to learn about networking, or vice versa.

Project Description

List all project components, such as courses, exams, and other learning products here:

- Associate Level DC 1.
- Associate Level DC 2

Course Description

- DCICN and DCICT will introduce the students to the technologies that are used in the Cisco Data Center: Unified Computing, Unified Fabric, and Network Services. The introductory level of knowledge that is taught in these courses is targeted for individuals that can perform only the more basic configuration tasks. The course labs will focus on and viewing configurations, but not making configuration changes or creating new topologies. Development Project Name: CCNA DC (DCICN and DCICT) Courses v1.0.
- Full Title of Course: Introduction to Cisco Data Center Technologies
- Course Acronym: DCICT
- Course Version Number: 1.0
- New course: Yes
- Replaces: N/A

Curricula

The course is used in the following curricula, certifications, specializations, and learning maps:

Certifications:

- Cisco Certified Network Associate – Data Center Cisco Certified Network Professional – Data Center.

Delivery Types

The course will be delivered in the following learning modes:

- Instructor lead training (ILT) - 5 days
- Instructor lead online (ILO) - 5 days

Deliverables

The materials and deliverables developed for the course are listed and described, including the percentage or hours of study and lecture materials, percentage or hours of practices (such as labs), and the total hours for a typical learner to complete the material.

- High Level Design Document (HLDD)
- Detailed Design Document (DDD)
- Course Administration Guide (CAG)
- Instructor Slides on CD – Microsoft PowerPoint presentations for a 5-day ILT (35 hours)
- Student Guides (SG) – Microsoft Word documents for a 5-day ILT (35 hours)
- Lab Guide (LG) – labs/demos/case studies will cover approximately 30 % of total ILT time

Target Audiences

This section specifies the primary and secondary target audiences of this course by job roles and notes the relevance to each job role.

Job Role	Relevance		
<input checked="" type="checkbox"/> Network Designer	<input checked="" type="checkbox"/> Primary	<input type="checkbox"/> Secondary	<input type="checkbox"/> Tertiary
<input checked="" type="checkbox"/> Network Administrator	<input type="checkbox"/> Primary	<input checked="" type="checkbox"/> Secondary	<input type="checkbox"/> Tertiary
<input checked="" type="checkbox"/> Storage Administrator	<input type="checkbox"/> Primary	<input checked="" type="checkbox"/> Secondary	<input type="checkbox"/> Tertiary
<input checked="" type="checkbox"/> Network Engineer	<input checked="" type="checkbox"/> Primary	<input type="checkbox"/> Secondary	<input type="checkbox"/> Tertiary
<input checked="" type="checkbox"/> Server Administrator	<input type="checkbox"/> Primary	<input checked="" type="checkbox"/> Secondary	<input type="checkbox"/> Tertiary
<input checked="" type="checkbox"/> Network Manager	<input type="checkbox"/> Primary	<input checked="" type="checkbox"/> Secondary	<input type="checkbox"/> Tertiary
<input checked="" type="checkbox"/> Program Manager	<input type="checkbox"/> Primary	<input type="checkbox"/> Secondary	<input checked="" type="checkbox"/> Tertiary
<input checked="" type="checkbox"/> Project Manager	<input type="checkbox"/> Primary	<input type="checkbox"/> Secondary	<input checked="" type="checkbox"/> Tertiary
<input checked="" type="checkbox"/> Systems Engineer	<input checked="" type="checkbox"/> Primary	<input type="checkbox"/> Secondary	<input type="checkbox"/> Tertiary
<input checked="" type="checkbox"/> Consulting Systems Engineer	<input checked="" type="checkbox"/> Primary	<input type="checkbox"/> Secondary	<input type="checkbox"/> Tertiary
<input checked="" type="checkbox"/> Technical Solutions Architect	<input checked="" type="checkbox"/> Primary	<input type="checkbox"/> Secondary	<input type="checkbox"/> Tertiary
<input checked="" type="checkbox"/> Cisco Integrators/Partners	<input checked="" type="checkbox"/> Primary	<input type="checkbox"/> Secondary	<input type="checkbox"/> Tertiary

Target Theaters and Locales

This course is targeted to a global audience.

Prerequisite Skills and Knowledge

This section lists the skills and knowledge that learners should possess to benefit fully from the course. It includes recommended Cisco learning offerings that the learners may complete to benefit fully from this course.

The knowledge and skills that a learner should have before attending this course are as follows:

- Introduction to Cisco Data Center Networking (DCICN) or equivalent knowledge.

Course Evaluation

Effectiveness of the course will be evaluated at these Levels of Kirkpatrick's performance evaluation.

- Level 1: Reaction to the course
 - Course effects: This assessment level gauges learner satisfaction, that is, feedback from participants regarding their levels of satisfaction with the offering. This assessment will consist of the Cisco standard program evaluation and will be completed by the learner.
 - Course evaluation: Required (via MTM)
- Level 2: Learning retained
 - Course effects: This assessment level tests for learner achievement following a portion, or all, of an instructional offering. The strategy for learner assessment calls for the use of written tests in support of the instructional program. Written tests will be administered in accordance with L@C standards through proctored certification exams. This assessment will consist of the laboratory exercises and the Cisco Certification Exam.
 - Course evaluation: Required
- Level 3: Performance changes after the course
 - Course effects: N/A
 - Course evaluation: N/A
- Level 4: Results on the job, after the course
 - Course effects: N/A

Assessment Strategy

This section specifies the assessment approach for the learning product.

- Module-level quizzes integrated into the course (with equal distribution of all types of questions, from recall- to evaluation-level)
- Lab activities with verification/answer-key sections
- Course exam

Assumptions and Risks

This section lists assumptions and risks and their implications related to development of this product.

Assumption or Risk	Implication
A development pod consisting of all the HW and SW equipment required to develop labs must be in place by the deadline of the Prototype delivery.	Delays in acquisition of lab HW/SW will materially delay the hand-off dates of the student guide, lab guide and CAG.
L@C TEC resources will be available to review design documents and content as stated in the accepted development schedule.	Inaccessibility of L@C TEC staff may delay the completion of project deliverables.
All UCS B-Series and C-Series firmware will be synchronized on UCS Manager 2.0 release. UCS C-Series Servers will operate in Standalone Mode on firmware 1.4x. The Nexus 5548UP switches will operate on NX-OS version 5.2(3)N2(2).	It is likely that new versions of software will become available during the development process. It will create a significant additional burden to developers to correct screen-shots and add discussions of new features to lecture and lab deliverables. This will materially impact the completion timeline.
QAS resources will be available to edit content as stated in the accepted development schedule.	Inaccessibility of L@C QAS staff may delay the availability dates of project deliverables.
Program scope does not change.	Further changes in scope may cause delays as those changes are discussed, and then the resulting changes are made to the schedule.

High-Level Course Design

Course Goal

The goal of the course is to supply attendees with broad exposure to Cisco Data Center technologies to provide entry-level data center personnel with the skills they require to succeed in their job role.

Job Tasks and Domain and Skill Objectives (formerly “Claims and Component Skills”)

#	Major Skills / Component Skills
1.0	Cisco Data Center Fundamentals Concepts:
1.1	Describe FabricPath
1.2	Describe Overlay Transport Virtualization (OTV)
1.3	Describe and verify Virtual Port Channel (vPC)
1.5	Describe Virtual Device Context (VDC)
1.6	Describe the edge/core layers of the Storage Area Network (SAN)
1.7	Describe the access/distribution/core layers of the Data Center (DC)
1.8	Describe the Cisco Nexus product family
1.9	Verify network connectivity
1.10	Identify control and data plane traffic
1.11	Perform initial set up
2.0	Data Center Unified Fabric:
2.1	Describe Fibre Channel over Ethernet (FCoE)
2.2	Describe FCoE Multi-hop
2.3	Describe Virtual Interfaces (VIFs)
2.4	Describe Fabric Extender (FEX) products
2.5	Perform initial set up
3.0	Storage Networking:
3.1	Describe initiator target
3.2	Verify Storage Area Network (SAN) switch operations
3.3	Describe basic Storage Area Network (SAN) connectivity
3.4	Describe the different storage array connectivity
3.5	Verify name server login
3.6	Describe and verify zoning
3.7	Perform initial set up
3.8	Describe and verify Virtual Storage Area Network (VSAN)

- 4.0 DC Virtualization:**
 - 4.1 Describe device Virtualization
 - 4.2 Describe Server Virtualization
 - 4.3 Describe Nexus 1000v
 - 4.4 Verify initial set up and operation for Nexus 1000v
- 5.0 Unified Computing:**
 - 5.1 Describe the Cisco Unified Computing System (UCS) product family
 - 5.2 Describe the Cisco Unified Computing System Manager (UCSM)
 - 5.3 Describe and verify cluster configuration
 - 5.4 Describe and verify discovery operation
 - 5.5 Describe and verify connectivity
 - 5.6 Perform initial set up
 - 5.7 Describe the key features of UCSM

Course Flow Diagram

This section illustrates the flow of the course.

Day 1: Describe and Verify Cisco Data Center Fundamentals		
	8:30–9:00 (0830–0900)	M0L0 Introduction
	9:00–9:50 (0900–0950)	M1L1 Functional Layers of the Data Center
	9:50–10:00 (0950–1000)	Break
	10:00–11:05 (1000–1105)	M1L2 Cisco Nexus Product Family
	11:05–11:15 (1105–1115)	Break
	11:15–12:10 (1115–1210)	M1L2 Cisco Nexus Product Family (cont)
	12:10–1:10 (1210–1310)	Lunch
	1:10–2:10 (1310–1345)	M1L3 Cisco MDS Product Family
	2:10–2:25 (1410–1425)	Break
	2:25–3:25 (1425–1525)	M1L4 Monitoring the Nexus 7000 and 5000 Series Switches

	3:25–3:40 (1525–1540)	Break
	3:40–4:20 (1540–1600)	Activity 1-1 Cisco Power Calculator, Activity 1-2 Cisco Nexus 7000 Series Initial Setup Script & Lab 1-1 Connect to the Cisco Nexus 7000 Series Switch Using SSH
	4:00–4:40 (1600–1640)	Activity 1-3 Cisco Nexus 5000 Series Initial Setup Script & Lab 1-2 Connecting to the Cisco Nexus 5000 Series Switch Using SSH
	4:40 (1640)	Day ends
Day 2: Describe Cisco Data Center Virtualization		
	8:30–9:00 (0830–0900)	Review of Day 1
	09:00-10:05 (0900-1005)	M1L5 Describing Port Channels, Virtual Port Channels, and FabricPath in the Data Center
	10:05-10:20 (1005-1020)	Break
	10:20-11:05 (1020-1105)	M1L6 Using OTV on Cisco Nexus 7000 Series Switches
	11:05-11:45 (1105-1145)	Lab 1-3 Running CLI Commands
	11:45-12:45 (1145-1245)	Lunch
	12:45-2:00 (1305-1400)	Lab 1-4 Configuring Virtual Port Channels
	2:00–2:15 (1400–14:15)	Break
	2:15–2:30 (1415–14:30)	Lab 1-5 Validate Cisco FabricPath Configuration
	2:30–2:45 (1430–14:45)	Lab 1-6 Validate OTV Configuration
	2:45-3:55 (1445-1555)	M2L1 Virtualizing Network Devices
	3:55-4:50 (1555-1650)	M2L2 Virtualizing Storage
	4:50 (1650)	Day ends

Day 3: Describe Cisco Data Center Storage Networking		
	8:30–9:00 (0830–0900)	Review of Day 2
	0900-0945 (09:00-09:45)	M2L3 Virtualizing Server Solutions
	09:45-10:15 (0945-1015)	M2L4 Using the Cisco Nexus 1000V Switch
	10:15-10:25 (1015-1025)	Break
	10:25-11:30 (1025-1130)	M2L4 Using the Cisco Nexus 1000V Switch (continued)
	1130-1145 (11:30-11:45)	M2L5 Verifying Setup and Operation of the Cisco Nexus 1000v Switch
	11:45-12:45 (1145-1245)	Lunch
	12:45-1:00 (1245-1300)	M2L5 Verifying Setup and Operation of the Cisco Nexus 1000v Switch (continued)
	1:00-1:30 (1300-1330)	Lab 2-1 Verify the Current VDC Settings & Lab 2-2 Validate the Cisco Nexus 2000 FEX Configuration
	1:30-2:15 (1330-1415)	Lab 2-3 Validate the Cisco Nexus 1000V Configuration
	2:15-3:20 (1415-1520)	M3L1 Comparing Storage Connectivity Options in the Data Center
	3:20-3:35 (1520-1535)	Break
	3:35-4:20 (1535-1620)	M3L2 Describing Fibre Channel Storage Networking
	4:20-4:45 (1620-1645)	M3L3 Verifying Fibre Channel Communications on Cisco MDS Switches
	4:45-5:00 (1645-1700)	Activity 3-1 Cisco MDS 9100 Series Switch Initial Setup
	5:00 (1700)	Day ends
Day 4: Describe Cisco Data Center Unified Fabric		
	8:30–9:00 (0830–0900)	Review of Day 3
	9:00-10:15 (0900-1015)	Lab 3-1 Validate the Cisco MDS 9100 Series Switch License , Lab 3-2 Configure VSAN's and Zoning, Lab 3-3 Validate Fabric Login and Fibre Channel Name Services & Lab 3-4 View the Tech-Support Output
	10:15-1030 (1015-1030)	Break
	10:30-11:30 (1030-1130)	M4L1 Describing Data Center Bridging
	11:30-1205 (1130-1205)	M4L2 Connectivity Options for FCoE on the Cisco Nexus 5000 Series Switch
	12:05-1:05 (1205-1305)	Lunch

	1:05-1:20 (1305-1320)	M4L3 Describing Enhanced FCoE Scalability with the Cisco Nexus 2232 Fabric Extender
	1:20-1:45 (1320-1345)	Lab 4-1 Validate the Physical Connections for FCoE
	1:45-2:25 (1345-1425)	M5L1 Cisco UCS B-Series Product Family (to PDF page 219)
	2:25-2:40 (1425-1440)	Break
	2:40-3:25 (1440-1525)	M5L1 Cisco UCS B-Series Product Family (from page 219 PDF)
	3:25-3:50 (1525-1550)	M5L2 Cisco UCS C-Series Product Family
	3:50-4:40 (1550-1640)	M5L3 Cisco UCS B-Series Connectivity
	4:40 (1640)	Day ends
Day 5: Describe Cisco Data Center Network Services		
	8:30–9:00 (0830–0900)	Review of Day 4 (including evaluations & feedback)
	9:00–9:15 (0900–0915)	M5L4 Cisco UCS C-Series Integration with Cisco UCS Manager
	9:15–9:30 (0915–0930)	M5L5 Configuring Cisco UCS B-Series Initial Cluster Setup
	9:30–10:10 (0930–1010)	M5L6 Cisco UCS Manager
	10:10-10:25 (1010-1025)	Break
	10:25-1100 (1025-1100)	M5L7 Cisco UCS Manager Pools, Policies, Templates and Service Profiles
	11:00-12:00 (1100-1200)	Activity 5-1 Cisco UCS 6120 Fabric Interconnect Initial Setup Script & Activity 5-2 Configuring Server Ports and Chassis Discovery
	12:00-1:00 (1200-1300)	Lunch
	1:00-3:00 (1300-1500)	Lab 5-1 Explore the Cisco UCS Manager GUI & Lab 5-2 Create a Service Profile from a Template and SAN-Boot VMware ESXi 5.0
	3:00–3:30 (1500–1530)	Wrap Up

Course Structure and Objectives

This section describes the high-level, modular structure of the course and lists the module and lesson objectives. Describe the high-level structure of the course and any principles that apply to all modules.

Module 0: Course Introduction

Module Objective: Inform participants of course flow, pre-requisite skills expectations, certification requirements and student introductions.

Module 1: Cisco Data Center Network Services

Module Objective: Articulate the features of the data center switches for network and SAN connectivity and their relationship to the layered design model.

Module 1 Notes: The purpose of this module is to introduce students to the topology layers of the Cisco data center LAN and SAN networks, as well as the key features of the Cisco Nexus 7000, 5000 and MDS switches. This module also covers an introduction to the Cisco virtual port channels, Cisco FabricPath and OTV. Remember, these students are associate level students, and you are meant to introduce them to new technologies that would be used in the data center. At the end of this module, students will be expected to be able to verify some basic configurations that you, as the instructor, will be introducing to the lab topology.

Module 1 Lesson 1: Functional Layers of the Data Center

M1L1 Objective: Articulate the functions of topology layers in Cisco Data Center network LAN and SAN networks. This lesson covers the following topics:

- Traditional Isolated LAN and SAN Networks
- LAN Core, Aggregation and Access Layers
- Core and Access Layers in a LAN Collapsed Core Design
- Core and Edge Layers in a Data Center SAN Design
- Collapsed Core SAN Design

M1L1 Job Tasks:

- 1.6 Describe the edge/core layers of the SAN
- 1.7 Describe the access/distribution/core layers of the DC

M1L1 Enabling Objectives:

- Describe the reasons for segregating LAN and SAN traffic
- Describe the layers and functions of the core, aggregation and access layers in the data center.
- Describe the reasons for combining the core and aggregation layers.
- Describe the core and edge layers in a data center SAN design
- Describe the reasons for combining the core and edge layers in a SAN design

M1L1 Notes: This lesson is meant to be introducing the students to the layered architecture of the data center. Ensure what students understand why LAN and SAN traffic has traditionally been separated architecturally, as this will help lead into the discussion on FCoE which is

covered later in the course. This course is not meant to be a design course; therefore, this is an overview of the layers for future references during the class.

Module 1 Lesson 2: Cisco Nexus Product Family

M1L2 Objective: Articulate the features of Cisco Nexus 7000, Nexus 5000, and Nexus 2000 products and their relationship to the layered design model. This lesson covers the following topics:

- Cisco Nexus Data Center Product Portfolio
- Cisco Nexus 7000 Chassis Options
- Cisco Nexus 7000 Supervisor Modules
- Cisco Nexus 7000 Switch Licensing Options
- Cisco Nexus 7000 Switch Fabric Modules
- Cisco Nexus 7000 I/O Modules
- Cisco Nexus 7000 Switch Power Supply Options
- Cisco Nexus 5000 Series Chassis Options
- Cisco Nexus 5010 and 5020 Switch Features
- Cisco Nexus 5010 and 5020 Expansion Modules
- Cisco Nexus 5500 Switch Features
- Cisco Nexus 5500 Switch Series Expansion Modules
- Cisco Nexus 5000 Switch Series Software Licensing
- Cisco Nexus 2000 Fabric Extender Function in the Cisco Data Center
- Cisco Nexus 2000 Fabric Extender Features

M1L2 Job Tasks:

- 1.5 Describe Nexus 7000 Virtual Device Contexts (VDCs)
- 1.7 Describe the access/distribution/core layers of the DC
- 1.8 Describe the Cisco Nexus product family

M1L2 Enabling Objectives:

- Describe Cisco's goal of data center transformation with Cisco Nexus products
- Describe the capacities of the Cisco Nexus 7000 Series chassis
- Describe the capabilities of the Cisco Nexus 7000 supervisor modules
- Describe licensing options for the Cisco Nexus Series switches
- Describe the capacities of the Cisco Nexus 7000 fabric modules
- Describe the capabilities of the Cisco Nexus 7000 I/O Modules
- Describe the capabilities of the Cisco Nexus 7000 power supplies
- Describe the Cisco Nexus 5000 and 5500 chassis
- Describe the Cisco Nexus 5010 and 5020 Series switches
- Describe expansion modules available for the Cisco Nexus 5010 and 5020 Series switches

- Describe the Cisco Nexus 5548P, 5548UP, and 5596 Series switches
- Describe the expansion modules available for Cisco Nexus 5548P, 5548UP, and 5596 Series switches
- Describe the software licensing for the Cisco Nexus 5000 Series switches
- Describe how the Cisco Nexus 2000 Fabric Extenders act as remote line modules
- Describe the Cisco Nexus 2000 Fabric Extenders

M1L2 Notes: This lesson covers a large amount of product information. There are product courses and the DCUFI class that will cover all these components in-depth, and students should be directed to those classes for further information. Provide students with a good overview of the product capabilities – the I/O modules are summarized in one or two slides. This lesson should take approximately 90 minutes.

Module 1 Lesson 3: Cisco MDS Product Family

M1L3 Objective: Articulate the features of the Cisco MDS Fibre Channel switches and their relationship to the layered design model. This lesson covers the following topics:

- Cisco MDS 9000 Series Product Suite
- Cisco MDS 9500 Series Chassis Options
- Cisco MDS 9500 Series Supervisor Modules
- Cisco MDS 9500 Series Licensing Options
- Cisco MDS 9500 Series I/O Modules
- Cisco MDS 9500 Series Power Supply Options
- Cisco MDS 9100 Series Fabric Switches
- Cisco MDS 9222i Multiprotocol Switch

M1L3 Job Tasks:

1.6 Describe the edge/core layers of the SAN

M1L3 Enabling Objectives:

- Describe the data center benefits of deploying Cisco MDS 9000 Series switches
- Describe the capacities of the Cisco MDS 9500 Series switch chassis
- Describe the capabilities of Cisco MDS 9500 Series switch supervisor modules
- Describe licensing options for Cisco MDS 9000 switches
- Describe the capabilities of the Cisco MDS 9500 Series I/O Modules
- Describe the capabilities of MDS 9500 power supplies
- Describe the capabilities of Cisco MDS 9100 Series fabric switches
- Describe the capabilities of Cisco MDS 9222i switch

M1L3 Notes: Introduce the Cisco MDS product family and demonstrate where they operate in the layered Cisco data center. Do not get tempted to cover this lesson in-depth. This lesson is meant to introduce the students to the Cisco MDS product family and how it can be implemented in the data center. If students require more information, then classes such as the ICSNS class can be suggested. This lesson should take approximately 45 minutes.

Module 1 Lesson 4: Monitoring the Cisco Nexus 7000 and 5000 Series Switches

M1L4 Objective: Perform an initial configuration and validate common features of the Cisco Nexus 7000 and 5000 switches. This lesson covers the following topics:

- Connecting to the Cisco Nexus 7000 and 5000 Series Switch Console Port
- Running the Initial Setup Script for the Cisco Nexus 7000 and 5000 Series Switch
- Connecting to the Cisco Nexus 7000 Connectivity Management Processor (CMP)
- Connecting to the Cisco Nexus Series Switch Using SSH to the Management VRF
- ISSU on the Cisco Nexus 7000 and 5000 Series Switches
- Verifying VLANs on the Cisco Nexus 7000 and 5000 Series Switches
- Operational Plane

- Cisco NX-OS Default Control Plane Policing
- Important CLI Commands

M1L4 Job Tasks:

- 1.9 Verify network connectivity
- 1.10 Identify control and data plane traffic CoPP (Nexus)
- 1.11 Perform initial set up

M1L4 Enabling Objectives:

- Describe the requirements to connect to the Cisco Nexus 7000 and 5000 Series switch console port
- Describe the requirements of the Cisco Nexus 7000 and 5000 Series switch setup script
- Describe the requirements to connect to the Connectivity Management Processor on the Cisco Nexus 7000 Series switch
- Connect to the Cisco Nexus Series Switch Using SSH to the Management VRF
- Describe the ISSU capabilities of the Cisco Nexus 7000 and 5000 Series switches
- Describe VLANs on the Cisco Nexus 7000 and 5000 Series switches

M1L4 Notes: This lesson starts off with explaining to students how console connectivity is achieved and how to perform an initial configuration on the Cisco Nexus switches. Students will not be performing this initial configuration, but the instructor will demonstrate the configuration in one of the following lab activities. This lesson is meant to provide the students with the skills necessary to validate the initial and basic configuration of the Cisco Nexus switches.

Module 1 Activity 1-1: Cisco Power Calculator (Instructor Demonstration Only)

M1Activity 1-1 Objectives: Log in to CCO and access the Cisco Power Calculator to show students how to use the tool:

- Show students how to access the Cisco Power Calculator
- Show students how to use the Cisco Power Calculator

M1Activity 1-1 Verification: The instructor will have successfully explained to the students through an online demonstration how to use the Cisco Power Calculator.

M1Activity 1-1 Notes: This activity is designed to show the students how to use the Cisco Power Calculator. Many students will not have a CCO login which is the reason this activity is an instructor demonstration.

Module 1 Activity 1-2: Cisco Nexus 7000 Initial Setup Script (Instructor Demonstration Only)

M1Activity 1-2 Objectives: Log on to the Cisco Nexus 7000 and demonstrate how to perform an initial setup:

- Describe how to use the initial setup script to perform an initial configuration on the Cisco Nexus 7000 switch
- Describe which parameters should be set during the initial configuration on the Cisco Nexus 7000 switch

- Describe which parameters have default settings in the initial setup script on the Cisco Nexus 7000 switch

M1Activity 1-2 Verification: The instructor will have successfully demonstrated how to perform an initial setup on the Cisco Nexus 7000 switch using the setup script.

M1Activity 1-2 Notes: This activity is designed to show the students how to perform an initial setup on the Cisco Nexus 7000 switch. For the purposes of this course students will not have the ability to perform the initial setup themselves, hence the demonstration. An alternative to actually running through the setup would be to go through this activity as a paper-based activity.

Module 1 Lab 1-1: Connect to the Cisco Nexus 7000 Switch

M1Lab 1-1 Objectives: Use an SSH application to connect to the Cisco Nexus 7000 switch to run various show commands:

- Describe how to connect to the Cisco Nexus 7000 switch using SSH
- Describe how to use show commands to verify the management 0 interface configuration
- Describe how to use the show commands to verify the management 0 interface connectivity

M1Lab 1-1 Verification: The student will understand how to connect to the Cisco Nexus 7000 switch using SSH to run show commands for verification, and be able to test interface connectivity.

M1Lab 1-1 Notes: This lab is designed to provide the student with experience using an SSH application for management access to the Cisco Nexus 7000 switch.

Module 1 Activity 1-3: Cisco Nexus 5000 Initial Setup Script (Instructor Demonstration Only)

M1Activity 1-3 Objectives: Log on to the Cisco Nexus 5000 switch to perform an initial configuration using the setup script:

- Describe how to use the initial setup script to perform an initial configuration on the Cisco Nexus 5000 switch
- Describe which parameters should be set during the initial configuration on the Cisco Nexus 5000 switch
- Describe which parameters have default settings in the initial setup script on the Cisco Nexus 5000 switch

M1Activity 1-3 Verification: The instructor has successfully demonstrated to students how to perform an initial setup on the Cisco Nexus 5000 switch using the setup script.

M1Activity 1-3 Notes: This activity is designed to demonstrate to the students the use of the setup script to perform an initial configuration on the Cisco Nexus 5000 switch. As an alternative to actually performing this setup, instructors could run through the configuration as a paper-based activity.

Module 1 Lab 1-2: Connecting to the Cisco Nexus 5000 Switch using SSH

M1Lab 1-2 Objectives: Use an SSH application to connect to the Cisco Nexus 7000 switch to run various show commands:

- Describe how to connect to the Cisco Nexus 5000 switch using SSH
- Describe how to use show commands to verify the management 0 interface configuration

- Describe how to use the show commands to verify the management 0 interface connectivity

M1Lab 1-2 Verification: The student will understand how to connect to the Cisco Nexus 5000 switch using SSH to run show commands for verification, and be able to test interface connectivity.

M1Lab 1-2 Notes: This lab is designed to provide the student with experience using an SSH application for management access to the Cisco Nexus 5000 switch.

Module 1 Lesson 5: Describing Port Channels, Virtual Port Channels (vPC), and FabricPath in the Data Center

M1L5 Objective: Articulate the utility of port channels, vPCs, and Cisco FabricPath to interconnect data center switches. This lesson covers the following topics:

- Virtual Port Channels (vPC)
- Verifying vPCs
- Cisco FabricPath
- Verifying Cisco FabricPath

M1L5 Job Tasks:

- 1.1 Describe FabricPath
- 1.3 Describe and verify vPC

M1L5 Enabling Objectives:

- Describe Virtual Port Channels
- Verify virtual Port Channels (vPC) on the Cisco Nexus 7000 and 5000 Series switches
- Describe Cisco FabricPath on the Cisco Nexus 7000 and Nexus 5500 Series switches
- Verify Cisco FabricPath on the Cisco Nexus 7000 and 5500 Series switches

M1L5 Notes: This lesson is meant to provide students with a basic understanding of virtual port channels and Cisco FabricPath. These topics are covered in more detail in the product courses and the DCUFI class. At the end of this lesson, students should have a basic understanding of these technologies and be able to verifying basic configurations that involve these technologies. As the instructor, you will introduce the virtual port channel and Cisco FabricPath configurations into the lab topology so that students can use the verification commands.

Module 1 Lesson 6: Using OTV on Cisco Nexus 7000 Series Switches

M1L6 Objective: Describe Overlay Transport Virtualization (OTV) as a method of Data Center Interconnect (DCI). This lesson covers the following topics:

- OTV on the Cisco Nexus 7000 switch
- Verifying OTV on the Cisco Nexus 7000 switch

M1L6 Job Tasks:

- 1.2 Describe Overlay transport Virtualization (OTV)

M1L6 Enabling Objectives:

- Describe OTV on the Cisco Nexus 7000 Series switch
- Verify OTV on the Cisco Nexus 7000 Switch

M1L6 Notes: Use this lesson to introduce students to the concept of OTV and how to monitor and verify the OTV configuration. Similar to the previous lesson, this technology is covered in more detail in the product courses and the DCUFI class. Students should be able to verify and monitor an OTV configuration that you, as the instructor, will introduce to the lab topology.

Module 1 Lab 1-3: Running CLI Commands

M1Lab 1-3 Objectives: Connect to the Cisco Nexus 7000 and 5000 switches to run various show commands:

- Describe how to use the show commands to verify VLANs and VLAN membership
- Describe how to use the show commands to verify which interfaces are operational
- Describe how to use the show commands to verify the mac address table
- Describe how to verify which Cisco NX-OS version is running on the switch
- Describe how to verify the running and startup configurations
- Describe how to use the show commands to verify if there are any connectivity issues in the network

M1Lab 1-3 Verification: The student will understand how to use the show commands to verify VLANs, operation of interfaces, mac address tables, the version of Cisco NX-OS running on the switch, configuration files and if there are any connectivity issues in the network.

M1Lab 1-3 Notes: This lab is designed to provide the student with experience using show commands on the Cisco Nexus switches.

Module 1 Lab 1-4: Configuring Virtual Port Channels

M1Lab 1-4 Objectives: Connect to the Cisco Nexus 7000 and 5000 switches to configure and verify Virtual Port Channels (VPC):

- Verify the existing topology and configuration
- Configure and verify the vPC domain, vPC peer-link and vPC peer keepalive link
- Configure and verify the virtual port channels to the downstream switches
- Use show commands to verify the overall vPC operation
- Save the running configurations

M1Lab 1-4 Verification: The student will understand how to use the show commands to verify a Virtual Port Channels.

M1Lab 1-4 Notes: This lab is designed to provide students with experience configuring and verifying virtual port channel configuration.

Module 1 Lab 1-5: Validate Cisco FabricPath

M1Lab 1-5 Objectives: Connect to the Cisco Nexus 7000 and 5000 switches to verify the Cisco FabricPath configuration:

- Describe how to use the show commands to validate the Cisco FabricPath configuration

M1Lab 1-5 Verification: The student will understand how to use the show commands to verify a Cisco FabricPath configuration that was preloaded by the instructor.

M1Lab 1-5 Notes: This lab is designed to provide students with experience using the show commands to validate a Cisco FabricPath configuration.

Module 1 Lab 1-6: Validate OTV Configuration

M1Lab 1-6 Objectives: Connect to the Cisco Nexus 7000 switch to verify the Cisco OTV configuration:

- Describe how to use the show commands to validate the Cisco OTV configuration

M1Lab 1-6 Verification: The student will understand how to use the show commands to verify a Cisco OTV configuration that was preloaded by the instructor.

M1Lab 1-6 Notes: This lab is designed to provide the student with experience using the show commands to validate a Cisco OTV configuration.

Module 2: Cisco Data Center Virtualization

Module Objective: Describe the functions and benefits of virtualization in the Cisco Data Center

Module Notes: This module introduces students to virtualization technologies utilized within the data center. An overview of network device, storage and server virtualization will be followed by an introduction to the Cisco Nexus 1000v and the benefits of this technology within the data center.

Module 2 Lesson 1: Virtualizing Network Devices

M2L1 Objective: Describe the virtualization capabilities of the Cisco Nexus 7000 and 5000 data center switches. This lesson covers the following topics:

- Virtual Device Contexts on the Cisco Nexus 7000 Series Switch
- Verifying VDCs on the Cisco Nexus 7000 Series Switch
- Navigating Between VDCs on the Cisco Nexus 7000 Series Switch
- Network Interface Virtualization on the Cisco Nexus 7000 and 5000 Series Switches

M2L1 Job Tasks:

4.1 Describe Device Virtualization

M2L1 Enabling Objectives:

- Describe VDCs on the Cisco Nexus 7000 Series switches
- Verify VDCs on the Cisco Nexus 7000 Series switch.
- Describe how to navigate between VDCs on the Cisco Nexus 7000 Series switch
- Describe NIV on the Cisco Nexus 7000 and 5000 Series switch

M2L1 Notes: This lesson introduces students to the concept of virtual device contexts on the Cisco Nexus 7000 switch before then introducing them to the concept of Network Interface Virtualization (NIV). At the end of this lesson, students should be comfortable with navigating between VDCs, understand the purpose and use of VDCs, and how to verify VDC

configurations. Students should also be able to articulate the concept of network interface virtualization and where it would be found in the data center architecture.

Module 2 Lesson 2: Virtualizing Storage

M2L2 Objective: Describe how storage is virtualized for high availability and configuration flexibility. This lesson covers the following topics:

- LUN storage virtualization
- Storage system virtualization

M2L2 Job Tasks:

4.1 Describe Device Virtualization

M2L2 Enabling Objectives:

- Describe logical disk partitions
- Describe how storage controllers can virtualize the backend storage from multiple vendors for a single point of management

M2L2 Notes: This lesson is meant to introduce students to the concept of storage virtualization. At an associate level, you will probably find that students have little or no exposure to storage virtualization. Use this lesson to introduce the technology and how storage virtualization can be achieved.

Module 2 Lesson 3: Virtualizing Server Solutions

M2L3 Objective: Describe the benefits of server virtualization in the Data Center. This lesson covers the following topics:

- Benefits of Server Virtualization
- Data Center Server Virtualization Solutions

M2L3 Job Tasks:

4.2 Describe Server Virtualization

M2L3 Enabling Objectives:

- Describe the benefits of server consolidation in the Cisco Data Center
- Describe available data center server virtualization solutions

M2L3 Notes: This lesson introduces the students to the different virtualization solutions, although 85% of the lesson covers the VMware solution. This is not meant to be a complete VMware class in one lesson, but an introduction to how the virtualization solutions are used, their benefits and who administers which portion of the server virtualization implementation. Use this lesson to lead in to lesson 4 which will introduce the Cisco Nexus 1000v and its benefits over the VMware vDS solution.

Module 2 Lesson 4: Using the Cisco Nexus 1000V Switch

M2L4 Objective: Describe the problems solved by Cisco Nexus 1000v and how the Virtual Supervisor Module (VSM) and Virtual Ethernet Module (VEM) integrate with VMware ESX. This lesson covers the following topics:

- The limitations of the VMware vSwitch
- The Advantages of the VMware vNetwork Distributed Switch (vDS)
- How the Cisco Nexus 1000v switch takes network visibility to the virtual machine level
- How the VSM and VEM integrate with VMware ESX or ESXi and vCenter

M2L4 Job Tasks:

4.2 Describe Server Virtualization

4.3 Describe Cisco Nexus 1000v

M2L4 Enabling Objectives:

- Describe the limitations of the VMware vSwitch
- Describe the Advantages of the VMware vNetwork Distributed Switch
- Describe how the Cisco Nexus 1000V switch takes network visibility to the virtual machine level
- Describe how the VSM and VEM integrate with VMware ESX or ESXi and vCenter

M2L4 Notes: For most students this will be the first time they have encountered the Cisco Nexus 1000v, and may well have been the first time they encountered server virtualization solutions. This lesson is meant to provide students with a basic understanding of the capabilities and benefits of the Cisco Nexus 1000v in the data center architecture. At the end of this lesson, students should understand the components of the Cisco Nexus 1000v and its positioning in the data center. This lesson will take approximately 90 minutes.

Module 2 Lesson 5: Verifying Setup and Operation of the Cisco Nexus 1000v switch

M2L5 Objective: Use the VMware ESX CLI console and the Cisco Nexus 1000v VSM to validate connectivity of VSM to VEMs and vCenter. This lesson covers the following topics:

- Verify the initial configuration and module status on the Cisco Nexus 1000V
- Identifying how to verify the VEM status on the ESX or ESXi host
- Identifying how to validate Virtual Machine port groups

M2L5 Job Tasks:

4.4 Verify initial setup and operation for Cisco Nexus 1000v

M2L5 Enabling Objectives:

- Identify the commands that are used to verify the initial configuration and module status on the Cisco Nexus 1000V
- Identify how to verify the VEM status on the ESX or ESXi host
- Identify how to validate Virtual Machine port groups

M2L5 Notes: Students are not being asked to perform any configuration on the Cisco Nexus 1000v switch, so this lesson is being used to provide them with the commands they would use to verify the initial configuration, validate connectivity between the Cisco Nexus 1000v and the vCenter server, and how to verify that policies have been configured and pushed down to the vCenter server for use.

Module 2 Lab 2-1: Verify the Current VDC Settings

M2Lab 2-1 Objectives: Connect to the Cisco Nexus 7000 switch to verify the current VDC settings:

- Describe how to use the show commands to verify the settings that are configured for a VDC

M2Lab 2-1 Verification: The student will understand how to use the show commands to verify the current VDC settings on the Cisco Nexus 7000 switch.

M2Lab 2-1 Notes: This lab is designed to provide the student with experience using the VDC show commands to verify the VDC settings on the Cisco Nexus 7000 switch.

Module 2 Lab 2-2: Validate the Cisco Nexus 2000 FEX Configuration

M2Lab 2-2 Objectives: Connect to the Cisco Nexus 5000 switch to validate the Cisco Nexus 2000 Fabric Extender configuration:

- Describe how to use the show commands to validate a Cisco Nexus 2000 FEX configuration

M2Lab 2-2 Verification: The student will understand how to use the show commands to validate a Cisco Nexus 2000 FEX connected to a Cisco Nexus 5000 switch configuration using a preload configuration file.

M2Lab 2-2 Notes: This lab is designed to provide the student with experience using the show commands to verify a Cisco Nexus 2000 FEX configuration that was preloaded by the instructor.

Module 2 Lab 2-3: Validate the Cisco Nexus 1000V Configuration

M2Lab 2-3 Objectives: Validate the Cisco Nexus 1000V configuration:

- Describe how to use the show commands to validate a Cisco Nexus 1000V configuration

M2Lab 2-3 Verification: The student will understand how to use the show commands to validate a preloaded Cisco Nexus 1000V configuration.

M2Lab 2-3 Notes: This lab is designed to provide the student with experience using the show commands to validate a preloaded Cisco Nexus 1000V configuration.

Module 3: Cisco Data Center Storage Networking

Module Objective: Describe the function of Cisco Data Center storage networking technologies and verify correct operation.

Module Notes: This module will introduce students to storage networking protocols and initial configuration and verification of the Cisco MDS 9000 Series switches.

Module 3 Lesson 1: Comparing Storage Connectivity Options in the Data Center

M3L1 Objective: Compare Internet Small Computer System Interconnect (iSCSI), Fibre Channel, and Network Attached Storage (NAS) connectivity for remote server storage. This lesson covers the following topics:

- Comparing Block and File-Based Network Storage

- NFS, Fibre Channel, iSCSI and SCSI
- SCSI Evolution from DAS to SAN

M3L1 Job Tasks:

3.4 Describe the different storage array connectivity options

M3L1 Enabling Objectives:

- Compare the NAS and SAN approaches to network storage
- Describe the NFS, Fibre Channel, iSCSI and SCSI protocols for transporting data between servers and remote storage devices
- Describe the evolution of SCSI from Direct Attached Storage to SAN

M3L1 Notes: This lesson introduces students to several protocols. The next lesson will cover Fibre Channel in more detail, so there is no need to do so here. The purpose of this lesson is to ensure that students understand the basic functionality of SCSI and the different transport options that are available.

Module 3 Lesson 2: Describing Fibre Channel Storage Networking

M3L2 Objective: Explain the Fibre Channel topologies and how communication is established between an initiator and target device on the SAN. This lesson covers the following topics:

- Fibre Channel SAN topologies
- Fibre Channel port types
- Fibre Channel addressing
- Fibre Channel layered model
- Fibre Channel name server and fabric login (FLOGI) processes
- Fibre Channel zoning and LUN masking

M3L2 Job Tasks:

3.1 Describe Initiator to Target

3.3 Describe Basic Storage Area Network (SAN) Connectivity

3.6 Describe and verify zoning

M3L2 Enabling Objectives:

- Describe Fibre Channel SAN topologies
- Describe Fibre Channel port types
- Describe Fibre Channel addressing
- Describe the Fibre Channel layered model
- Describe the Fibre Channel Name Server and fabric login process
- Describe the use of Fibre Channel zoning and logical unit number masking

M3L2 Notes:

Introduce Fibre Channel communications from the initiator to target. High-level discussion of Fibre Channel communication layers, FLOGI, PLOGI, and PRLI. This lesson is often best delivered through an interactive white-board session.

Module 3 Lesson 3: Verifying Fibre Channel Communications on Cisco MDS Switches.

M3L3 Objective: Perform an initial configuration of a Cisco MDS 9000 Series Fibre Channel switch and use various show commands. This lesson covers the following topics:

- Configure an Cisco MDS 9000 Series Switch from the CLI Setup Script
- Update the Cisco NX-OS on a Cisco MDS 9000 Series switch
- Update Licensed Features on the Cisco MDS 9000 Series Switch
- Verify Initiator and Target Fabric Login
- Verify Fibre Channel Zoning on a Cisco MDS 9000 Series Switch
- Collect Tech Support Data on a Cisco MDS 9000 Series Switch

M3L3 Job Tasks:

- 3.7 Perform initial set up
- 3.8 Describe and verify VSAN
- 3.2 Verify SAN Switch Operations
- 3.5 Verify Name Server Login
- 3.6 Describe and verify zoning

M3L3 Enabling Objectives:

- Configure a Cisco MDS 9000 Series switch from the CLI setup script
- Update a Cisco MDS 9000 Series switch from the CLI setup script
- Update licensed features on a Cisco MDS 9000 Series switch
- Verify initiator and target fabric login
- Verify Fibre Channel zoning on a Cisco MDS 9000 Series switch
- Collect tech support data on a Cisco MDS 9000 Series switch

M3L3 Notes:

Guide students through the console setup script to create the basic MDS switch configuration. Demonstrate show commands to validate VSANs, zoning and fabric login.

Module 3 Activity 3-1: Cisco MDS 9100 Series Switch Initial Setup (Instructor Demonstration Only)

M3Activity 3-1 Objectives: Connect to the Cisco MDS switch and demonstrate how to perform an initial configuration:

- Describe how an initial setup is performed on a Cisco MDS 9100 switch

M3Activity 3-1 Verification: The instructor has demonstrated how to perform an initial setup on the Cisco MDS 9100 switch using the setup script.

M3Activity 3-1 Notes: This lab is designed to show the students how an initial setup would be performed on the Cisco MDS 9100 switch using the initial setup script. Students will not have the rights to perform this initial setup themselves, hence why this is an instructor activity. If the instructor wishes, he or she can perform this as a paper-based activity.

Module 3 Lab 3-1: Validate the Cisco MDS 9100 Series Switch License

M3Lab 3-1 Objectives: Validate the Cisco MDS 9100 Series switch license and features:

- Describe how to validate the license on a Cisco MDS 9100 Series switch

M3Lab 3-1 Verification: The student will understand how to use the show commands to identify the license being used on the switch, the default licenses available, and which features are currently in use.

M3Lab 3-1 Notes: This lab is designed to provide the student with experience the show commands to validate the licenses and features of the Cisco MDS 9100 switch.

Module 3 Lab 3-2: Configure VSAN's and Zoning

M3Lab 3-2 Objectives: Configure and verify VSANs and zone services in the switch fabric to logically isolate SAN traffic in SAN-A and SAN-B:

- Verify the existing topology and default configuration
- Configure and verify Virtual SAN's (VSAN) to provide logical isolation for SAN traffic between SAN-A and SAN-B
- Optimize VSAN trunking
- Configure and verify the zone configuration to ensure that initiators can see their proper storage targets.
- Use show commands to verify the configuration
- Save the running configurations

M3Lab 3-2 Verification: The student will understand how to configure and verify VSANs and zoning on both the Cisco Nexus 5000 Series and Cisco MDS 9100 Series switches.

M3Lab 3-2 Notes: This lab is designed to provide the student with experience in configuring VSANs and zoning on both the Cisco Nexus 5000 Series and Cisco MDS 9100 Series switches.

Module 3 Lab 3-3: Validate Fabric Login and Fibre Channel Name Services

M3Lab 3-3 Objectives: Connect to the Cisco MDS 9100 switch to validate the FLOGI and FCNS databases:

- Describe how to verify that initiators and targets have been able to successfully log in to the fabric.
- Describe how to verify Fibre Channel Name Services to ensure that devices have registered with the fabric.

M3Lab 3-3 Verification: The student will understand how to use the show commands to validate the FLOGI, and FCNS databases on the Cisco MDS 9100 switch using a preloaded configuration.

M3Lab 3-3 Notes: This lab is designed to provide the student with experience using the show commands to validate the FLOGI, and FCNS databases on the Cisco MDS 9100 switch using a configuration file preloaded by the instructor.

Module 3 Lab 3-4: View the Tech-Support Output

M3Lab 3-4 Objectives: Connect to the Cisco MDS 9100 switch and view the tech-support outputs:

- Describe how to view the tech-support outputs on the Cisco MDS 9100 switch

M3Lab 3-4 Verification: The student will understand how to use the show tech-support commands.

M3Lab 3-4 Notes: This lab is designed to provide the student with experience using the show tech-support commands.

Module 4: Cisco Data Center Unified Fabric

Module Objective: Articulate the function of Cisco Data Center Unified Fabric technologies and verify correct operation.

Module 4 Lesson 1: Describing Data Center Bridging

M4L1 Objective: Describe Data Center Bridging (DCB) and the IEEE standards that allow for a lossless Fibre Channel fabric to be transported over Ethernet. This lesson covers the following topics:

- Unified Fabric Benefits
- IEEE Standards that Enable Fibre Channel over Ethernet
- Priority Flow Control
- Enhanced Transmission Selection
- Data Center Bridging eXchange

M4L1 Job Tasks:

- 2.1 Describe FCoE
- 2.2 Describe FCoE Multi-hop

M4L1 Enabling Objectives:

- Describe the benefits of a Unified Fabric and the FCoE Protocol
- Describe the IEEE Standards that enable Fibre Channel over Ethernet and the FIP Protocol
- Describe Priority Flow Control
- Describe Enhanced Transmission Selection
- Describe Data Center Bridging eXchange

M4L1 Notes: This lesson introduces the students to the FCoE protocol, FIP and the DCB standards required for enabling a converged LAN and SAN infrastructure. The content in this lesson is provided for a high-level overview of these technologies. Using the content already covered in the Fibre Channel lesson, and student understanding of networking, relate concepts to topics they are already aware of to make the learning process simpler.

Module 4 Lesson 2: Connectivity Options for FCoE on the Cisco Nexus 5000 Series Switch

M4L2 Objective: Identify connectivity options for connecting the Converged Network Adapter (CNA) to the Cisco Nexus 5000 Series switch and the switch to upstream LAN and SAN environments. This lesson covers the following topics:

- Small Form-Factor Pluggable (SFP) modules

- Cabling requirements and distance limitations for common SFP and enhanced SFP (SFP+) transceivers
- Connecting the Cisco P81E Virtualization Interface Card to Cisco Nexus 5500UP Unified Fabric Switches
- Connecting the Cisco Nexus 5500UP Unified Fabric Switches to Northbound LAN and SAN Fabrics

M4L2 Job Tasks:

2.5 Perform initial set up

M4L2 Enabling Objectives:

- Describe small form-factor pluggable modules
- Describe cabling requirements and distance limitations for common SFP and enhanced SFP transceivers
- Connect the Cisco P81E virtualization interface card to the Cisco Nexus 5500UP Unified fabric switch
- Connect the Cisco Nexus 5500UP Unified fabric switch to northbound LAN and SAN Fabrics

M4L2 Notes: This lesson provides students with details relating to cabling requirements on the Cisco Nexus switches when using FCoE. If instructors have spare cables, it would be beneficial to the students to show them the different cabling options available.

Module 4 Lesson 3: Describing Enhanced FCoE Scalability with the Cisco Nexus 2232 Fabric Extender

M4L3 Objective: Describe the role of Network Interface Virtualization (NIV) with the Cisco Nexus 2232 in DCB/FCoE deployments. This lesson covers the following topics:

- Scaling the Data Center Virtualized Access Layer with the Cisco Nexus 2000 Fabric Extender
- Cisco Nexus 2232 Fabric Extender to Cisco Nexus 5500 Switch Connectivity
- Adapter FEX with the Cisco Nexus 2232 Fabric Extender
- Verifying Adapter FEX with the Cisco Nexus 2232 Fabric Extender

M4L3 Job Tasks:

2.4 Describe FEX products

2.3 Describe VIFs

M4L3 Enabling Objectives:

- Describe how the Cisco Nexus 2232 Fabric Extender increases scalability of FCoE deployments
- Describe the Cisco Nexus 2232 Fabric Extender connectivity to the Cisco Nexus 5500 Series switch
- Describe adapter FEX with the Cisco Nexus 2232 Fabric Extender
- Verify adapter FEX with the Cisco Nexus 2232 Fabric Extender

M4L3 Notes: This lesson introduces the students to how the Cisco Nexus 2232 Fabric Extender can be used to scale the FCoE deployment in the data center. The Cisco Nexus 2200 Fabric Extenders have already been covered in previous lessons, so this lesson is designed to show the scalability options for FCoE specifically, and to introduce the students to adapter-FEX deployments.

Module 4 Lab 4-1: Validate the Physical Connections for FCoE

M4Lab 4-1 Objectives: Validate the physical connections that are used for FCoE connectivity:

- Describe how to verify the physical connections that are required for FCoE

M4Lab 4-1 Verification: The student will understand how to validate the physical connections that are required for FCoE connectivity.

M4Lab 4-1 Notes: This lab is designed to provide the student with experience using the show commands on the Cisco Nexus 5000 switch to validate the physical connections for FCoE.

Module 5: Describe and Verify Cisco Unified Computing System

Module Objective: Articulate and verify correct operation of the components, connectivity and management of Cisco Unified Computing Systems.

Module 5 Lesson 1: Cisco UCS B-Series Product Family

M5L1 Objective: Describe the components of Cisco UCS B-Series

Topics

- Cisco UCS 6100 and 6200 series Fabric Interconnects
- Cisco UCS 5108 Blade Server Chassis
- Cisco UCS B200-M2 Blade Server
- Cisco UCS B230-M2 Blade Server
- Cisco UCS B250-M2 Blade Server
- Cisco UCS B440-M2 Blade Server
- Mezzanine Card Options for B-Series Blade Servers
- Memory Population Guidelines for B-Series Blade Servers

M5L1 Job Tasks:

5.1 Describe the Cisco UCS product family

M5L1 Enabling Objectives:

- Describe fabric interconnect options Describe the Cisco UCS 5108 Blade Server Chassis
- Describe the Cisco UCS B200-M2 Blade Server.
- Describe the Cisco UCS B230-M2 Blade Server
- Describe the Cisco UCS B250-M2 Blade Server
- Describe the Cisco UCS B440-M2 Blade Server
- Describe the features of B-Series mezzanine cards

- Describe the best practices for populating DRAM in the B-Series Blades.

Module 5 Lesson 2: *Cisco UCS C-Series Product Family*

M5L2 Objective: Describe Cisco UCS C-Series Product Family

Topics

- Cisco C-Series Product Family
- Cisco UCS C200-M2 Rack Server
- Cisco UCS C210-M2 Rack Server
- Cisco UCS C220-M2 Rack Server
- Cisco UCS C240-M2 Rack Server
- Cisco UCS C250-M2 Rack Server
- Cisco UCS C260-M2 Rack Server
- Cisco UCS C460-M2 Rack Server
- PCIe Adapter Options for C-Series Rack Servers
- RAID Adapter Options for C-Series Rack Servers
- Memory Population Guidelines for C-Series Rack Servers

M5L2 Job Tasks:

5.1 Describe the Cisco UCS product family

M5L2 Enabling Objectives:

- Describe the Cisco C-Series Product Family
- Describe the Cisco UCS C200-M2 Rack Server
- Describe the Cisco UCS C210-M2 Rack Server
- Describe the Cisco UCS C220-M2 Rack Server
- Describe the Cisco UCS C240-M2 Rack Server
- Describe the Cisco UCS C250-M2 Rack Server
- Describe the Cisco UCS C260-M2 Rack Server
- Describe the Cisco UCS C460-M2 Rack Server
- Describe the features of B-Series mezzanine cards
- Describe RAID adapter options for C-Series rack servers
- Describe the best practices for populating DRAM in the C-Series Rack Servers

Module 5 Lesson 3: *Cisco UCS B-Series Connectivity*

M5L3 Objective: Describe how Cisco UCS B-Series Servers Connect to the Chassis and Achieve External LAN and SAN Connectivity.

Topics

- Topic Objectives Chassis- to-Fabric Interconnect Physical Connectivity

- I/O Module Architectures
- Cisco Integrated Management Controller Chip on B-Series Blades
- Three Basic Port Personalities in the Fabric Interconnect
- Discovery Process

M5L3 Job Tasks:

5.5 Describe and verify connectivity

M5L3 Enabling Objectives:

- Describe the options for connecting a blade server chassis to the fabric interconnects
- Describe how physical connections from the fabric interconnect to the I/O module are routed to the various internal components of the blade servers.
- Describe the three main features of the baseboard management controller
- Describe the three basic states a 10 Gigabit Ethernet interface can be configured on the fabric interconnect.
- Describe the discovery process and how to monitor using Finite State Machine (FSM) output

Module 5 Lesson 4: *Configuring Cisco UCS B-Series Initial Cluster Setup*

M5L4 Objective: Describe the required information necessary to perform initial B-Series cluster setup and validate cluster operation.

Topics

- Cabling a UCS 6100 Fabric Interconnect Cluster
- Initial Setup Script for the Primary Peer
- Initial Setup Script for the Secondary Peer
- Verify Fabric Interconnect Cluster

M5L4 Job Tasks:

5.3 Describe and verify cluster configuration

5.6 Perform initial set up

M5L4 Enabling Objectives:

- Describe the required physical connectivity to create a fabric interconnect cluster
- Describe the information needed to configure the primary cluster peer
- Describe the information needed to configure the secondary cluster peer
- Verify that normal cluster communications and roles have been established

Module 5 Lesson 5: *Cisco UCS Manager*

M5L5 Objective: Describe how Cisco UCS Manager discovers new hardware, manages and monitors all UCS components

Topics

- Cisco Unified Computing System Manager

- Layout of the UCS Manager GUI
- Navigation Window Tabs
- Device Discovery in UCS Manager
- Verifying Device Discovery in UCS Manager

M5L5 Job Tasks:

5.2 Describe Cisco UCS Manager

5.4 Describe and verify discovery operation

M5L5 Enabling Objectives:

- Describe the functions of UCS Manager
- Describe the basic layout of UCS Manager
- Describe which configuration elements are configured under the six tabs of the navigation pane
- Describe how components are discovered by UCS Manager
- Verify Device Discovery in UCS Manager

Module 5 Lesson 6: *Cisco UCS Manager Pools, Policies, Templates, and Service Profiles.*

M5L6 Objective: Describe features of Cisco UCS Manager that allow for rapid provisioning and consistent application of policy.

Topics

- Benefits of Stateless Computing
- Using Identity Pools in Service Profiles
- Using Service Profile Templates to Enable Rapid Provisioning and Consistent Application of Policy
- Creation of Policies for Service Profiles and Service Profile Templates
- Chassis and Blade Power Capping

M5L6 Job Tasks:

5.7 Describe the key features of UCSM

M5L6 Enabling Objectives:

- Describe how the abstraction of hardware identities allows fast server mobility from one compute node to another
- Describe how pooled resources ensure uniqueness of identities assigned to Service Profiles
- Describe how Service Profile Templates allow rapid scaling of Cisco UCS
- Describe creating policies that map to service profiles and templates
- Describe creating chassis and blade power capping policies

Delivery Specifications

This section details the resources and requirements needed for delivery of the learning product.

Required Tools and Resources

Required Item	Explanation and Notes
Student access to remote lab devices	Provides transport for console/GUI access to lab devices
Student access to CCO documentation	Internet access
Student PC	A PC with RDP access to lab student VMs
Instructor PC	Instructor PC (usually provided by the instructor)

Supporting Personnel

Name	Function
Instructor	Help students complete lab exercises
Lab support	Resolve lab issues

Required Classroom Reference Materials

Required Item	Explanation and Notes
Student Guide	
Lab Guide	
Course Evaluation Form	
Course Administration Guide	
Instructor Slide Package	
Other	

Required Classroom Environment

The course requires a typical classroom for instructor-led training delivery of Cisco training:

- Whiteboards
- Projector
- PC's with at least 17" monitor
- Internet access
- Sufficient seating

Instructor Certification Requirements

Credentials to teach this version of the course are:

- CCSI in good standing
- CCNA or CCIE certification
- Cisco Data Center Networking Infrastructure Support Specialist certification
- Attend the TTT event or audit ICDC2 course and pass the respective exam at the instructor passing score

Laboratory Topology (Delivery)

General Information

A dedicated development environment will need to be in place to complete the Prototype for hand-off.

Overall Lab Description

The CCNA-DC lab consists of a Collapsed-Core LAN topology using Cisco Nexus 7009 switches at the Core layer. Access-layer connectivity is provided by Cisco 6120 Fabric Interconnects and Cisco 5548UP switches. SAN connectivity is achieved with redundant Cisco MDS 9124 Fibre Channel switches. The access layer LAN switches are configured to allow Fibre Channel over Ethernet (FCoE) and SAN boot to Cisco B200 blade servers and Cisco C200 rack servers.

Lab Topology Diagram (Backbone Pod View)

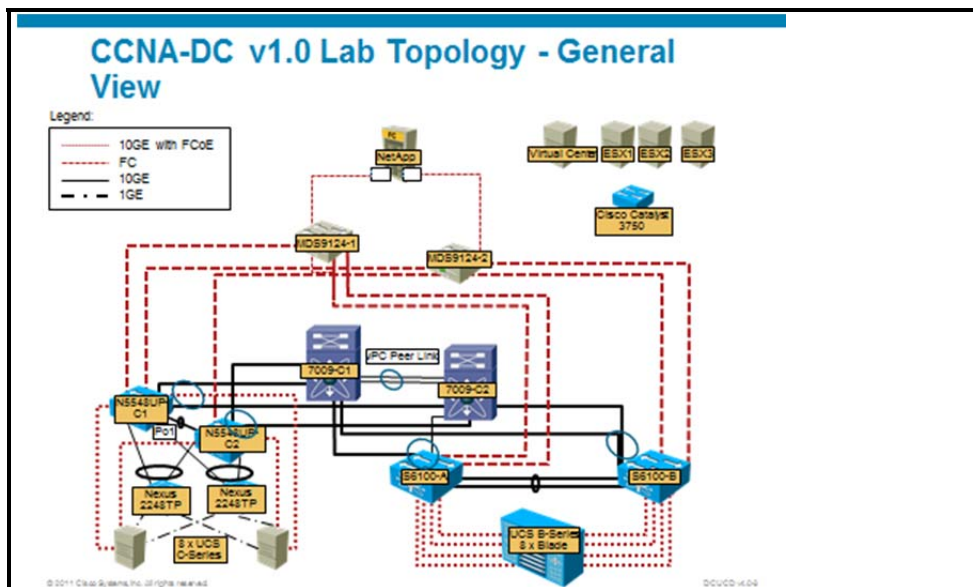

Lab Topology Diagram (Learner Pod View)

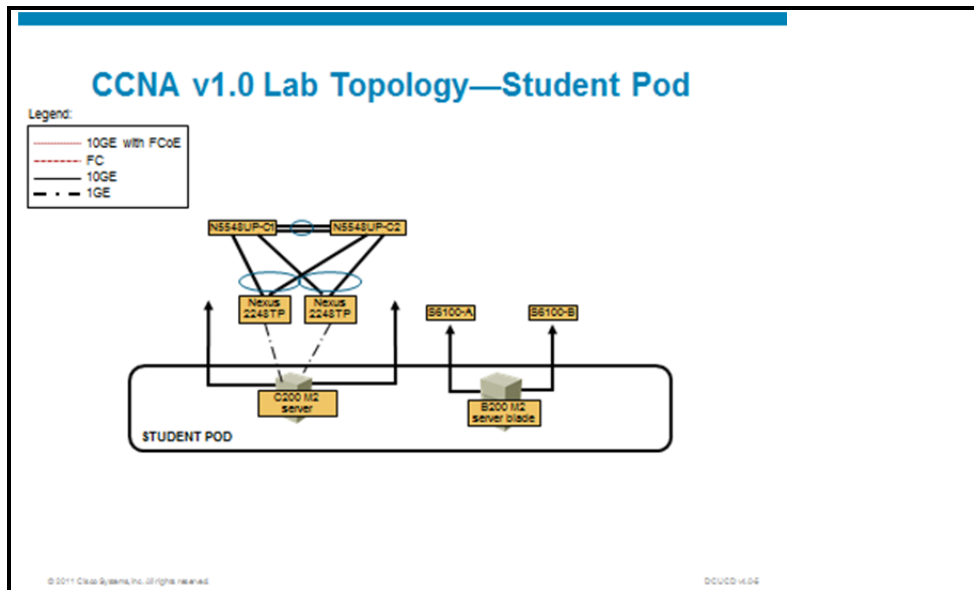

Laboratory Equipment

These tables list the recommended equipment to support the lab activities. These tables assume a class size of 16 learners. Learner Pod Equipment – 2 learners per pod – 8 pods total per class.

Description	Mfr.	Part Number	Total Qty.
Nexus 7009 Switch Chassis	Cisco	N7K-C7009	2
Nexus 7009 Fabric Module	Cisco	N7K-C7009-FAB-2	4
Nexus 7009 6Kw Power Supply	Cisco	N7K-AC-6.0kW	4
Nexus 6Kw Power Cable	Cisco	CAB-AC-C6K-TWLK	4
Nexus 7000 - 32 Port 1G/10G Ethernet Module	Cisco	N7K-F132XP-15	2
Cisco Nexus 7000 Series Supervisor Module	Cisco	N7K-SUP1	4
Cisco Nexus 7009 Rack Mount Kit	Cisco	N7K-C7009-RMK	2
Cisco Nexus 7009 Front Top Section and Cable Mgmt Kit	Cisco	N7K-C7009-CAB-TO	2
Cisco Nexus 7009 Bottom Support Kit	Cisco	N7K-C7009-BSK	2
Cisco Nexus 7009 Front Door Kit	Cisco	N7K-C7009-FD-MB	2
Advanced Services Package	Cisco	N7K-ADV1K9	2
Transport Services Package	Cisco	N7K-TRS1K9	2
Enhanced Layer 2 Package	Cisco	N7K-EL21K9	2

Laboratory Equipment (continued)

Description	Mfr.	Part Number	Total Qty.
Nexus 5548UP	Cisco	N5K-C5548UP-FA	2
Cisco Nexus 5000 Base OS Software Release 5.0(3)N1(1)	Cisco	N5KUK9-503N1.1	2
10GBASE-CU SFP+ Cable 5 Meter	Cisco	SFP-H10GB-CU5M	8
Power Cord, 125VAC 13A NEMA 5-15 Plug, North America	Cisco	CAB-9K12A-NA	4
4 Gbps Fibre Channel-SW SFP, LC	Cisco	DS-SFP-FC4G-SW	2
Accessory Kit for Nexus 5548 Chassis	Cisco	N5548-ACC-KIT	2
Nexus 5010 Storage Protocols Services License	Cisco	N5010-SSK9	2
Nexus 5010 PSU module, 100-240VAC 550W	Cisco	N5K-PAC-550W	2
Storage Protocols Services Package	Cisco	N55-8P-SSK9	2
FCoE NPV Package	Cisco	N5548-FNPV-SSK9	2
4Gbps Fibre Channel-SW SFP, LC	Cisco	DS-SFP-FC4G-SW=	4
10GBASE-CU SFP+ Cable 5 Meter		SFP-H10GB-CU5M	4
Cisco Nexus 2000 Series 1GE Fabric Extender, 2PS, 1 Fan Module, 24x100/1000Base-T + 2x10GE		N2K-C2224TP	2
10GBASE-CU SFP+ Cable 5 Meter		SFP-H10GB-CU5M	4
Nexus 1000V eDelivery CPU License Qty 1-Pack		L-N1K-VLCPU-01=	16
Cisco 3560-X with IP Base Image		WS-C3560X-48T-S	1
Two 10GbE SFP+ ports network module with four physical ports with two SFP+ and two regular SFP ports		C3KX-NM-10G	1
10GBASE-CU SFP+ Cable 5 Meter		SFP-H10GB-CU5M	2
MDS 9124 Fabric Switch		DS-C9124AP-K9	2
Optional redundant AC power supply (uninstalled), (CTO)		DS-C24-300AC	2
Power Cord, 125VAC 13A NEMA 5-15 Plug, North America		CAB-9K12A-NA	4
4Gbps Fibre Channel-SW SFP, LC		DS-SFP-FC4G-SW=	4

Laboratory Equipment (continued)

Description	Mfr.	Part Number	Total Qty.
Cisco UCS 6120XP Fabric Interconnect	Cisco	N10-S6100	2
Cisco UCS 5108 Chassis	Cisco	N20-C6508	1
Cisco UCS B-Series Server Blade	Cisco	N20-B6620-1	8
Cisco UCS 2104XP I/O Module	Cisco	N20-I6584	2
Cisco UCS M81KR VIC for B-Series Server Blade	Cisco	N20-AC0002	8
4Gbps Fibre Channel-SW SFP, LC	Cisco	DS-SFP-FC4G-SW=	8
10GBASE-CU SFP+ Cable 5 Meter	Cisco	SFP-H10GB-CU5M	12
Cisco UCS C-Series rack server with P81 NIC	Cisco	R200-1120402W	10
2.13GHz Xeon E5605 80W CPU/4MB cache/DDR3 800MHz	Cisco	A01-X0113	10
4GB DDR3-1333MHz RDIMM/PC3-10600/dual rank 1Gb DRAMs	Cisco	N01-M304GB1	30
Rail Kit - UCS C200, C210 and 250 M1 Rack Servers	Cisco	R250-SLDRAIL	10
Power Cord, 200/240V 6A North America	Cisco	CAB-N5K6A-NA	10
10GBASE-CU SFP+ Cable 5 Meter	Cisco	SFP-H10GB-CU5M	20
FAS2000 Series Storage Appliance	NetApp	FAS2040	1
Internal SAS 300GB Hard Drive	NetApp		6
Power Cord, 110V 30A North America	NetApp		2
Fibre Optic patch cords for Fibre Channel SFP	NetApp		8

Software List

Description	Mfr.	Part Number	Total Qty.
Windows 2008 R2	Microsoft		16
Windows 7 Enterprise	Microsoft		8
VMware ESXi 5.0 Enterprise plus	VMware		16
vCenter Server	VMware		8
IPMITool	Open Source		16
Cygwin	Open Source		16
3CDaemon Freeware	3Com		16
puTTY SSH	Simon Tatham		16

Notes on Delivery Lab Equipment

Development Lab Equipment Requirements

This section details the resources and requirements needed to develop and test the course labs.

Required Resources

Required Item	Explanation and Notes
Development Pod	All equipment needs to be remotely accessed during development, Alpha & Beta TTTs and TTT.

Supporting Personnel

Required Item	Explanation and Notes

Required Materials

- Previous version course files including CAG and Lab Guide
- Previous version config files
- Supporting information

Laboratory Topology (Development)

These tables list the recommended equipment to support the lab activities. These tables assume a class size of 16 learners.

Describe which equipment can be remote, and what must be physically accessible by the developer(s). Note any other considerations, such as number of pods, interconnections between pods, and external connections to servers or Internet.

Description	Mfr.	Part Number	Total Qty.
Learner Pod Equipment – 1 pods for development			
Other Required Equipment			

Software List

Description	Mfr.	Part Number	Total Qty.

Notes on Development Lab Equipment

Detailed Course Design

This section details Lesson, Topic, Activity, and Lab content within the Module and Lesson structure of the course. This Detailed Course Design section is updated while the course contents are developed. At the end of development, the Design Document will be an accurate blueprint of the final course content.

Module 0 of 5: Course Introduction

Module Objective: Advise participants of course flow, pre-requisite skills expectations, certification requirements and student introductions.

Module 0 Lesson 1 of 1

Lesson Objective: Course flow, pre-requisite skills recommendations, certification requirements, Cisco online resources, and student introductions.

Module 0 Lesson 1 Topic 1 of 5	Course Overview
Topic Objectives	Describe the course goal and objectives
Media Treatment (Visuals)	Lecture using static slides
Content Types or Media Objects	Graphical presentation of the course goal and its benefits. Describe the prerequisite learner skills and knowledge.
Sources	Adapt from DCUCI 4.0

Module 0 Lesson 1 Topic 2 of 5	Components of the CCNA-DC Curriculum
Topic Objectives	Provide an overview of certification requirements for CCNA-DC
Media Treatment (Visuals)	Lecture using static slides
Content Types or Media Objects	Provide graphic of positioning of course in Cisco Unified Computing Curriculum. Graphical diagram of course flow and all the components with explanation. Provide graphic of icons and symbols used in DCUCI
Sources	Adapt from DCUCI 4.0

Module 0 Lesson 1 Topic 3 of 5	Training Curriculum
Topic Objectives	Provide an overview of certification requirements for CCNA-DC
Media Treatment (Visuals)	Lecture using static slides
Content Types or Media Objects	Graphic of Cisco Associate, Pro/Expert Triangle
Sources	Adapt from DCUCI 4.0

Module 0 Lesson 1 Topic 4 of 5	Cisco Online Resources
Topic Objectives	Provide an overview of Cisco learning resources available online.
Media Treatment (Visuals)	Lecture using static slides
Content Types or Media Objects	Provide graphic of Partner Education Connection Provide graphic of Cisco Support Community Provide graphic of Cisco NetPro Forums
Sources	Adapt from DCUCI 4.0

Module 0 Lesson 1 Topic 5 of 5	Student Introductions
Topic Objectives	Get to know students and their motivations for attending the course.
Media Treatment (Visuals)	Interactive discussion.
Content Types or Media Objects	Provide a slide with bullets for name, company name, certification level and primary motivation for attending the course.
Sources	Adapt from DCUCI 4.0

Module 1 of 5: Cisco Data Center Network Services

Module Objective: Articulate the features of the Cisco data center switches for network and SAN connectivity and their relationship to the layered design model.

Module 1 Lesson 1 of 6 - Functional Layers of the Cisco Data

Lesson Objective: Describe the functions of topology layers in Cisco Data Center LAN and SAN networks.

Module 1 Lesson 1 Topic 1 of 5	Traditional Isolated LAN and SAN Networks
Topic Objectives	Describe the reasons for segregating LAN and SAN traffic
Media Treatment (Visuals)	Lecture using static slides
Content Types or Media Objects	Graphical presentation of separate physical transport of LAN and SAN networks. Graphical presentation of dis-similar LAN and SAN framing. Table comparing LAN and SAN packet loss and other requirements
Sources	
Module 1 Lesson 1 Topic 2 of 5	LAN Core, Aggregation and Access Layers
Topic Objectives	Describe the layers and functions of the core, aggregation and access layers in the data center.
Media Treatment (Visuals)	Lecture using static slides
Content Types or Media Objects	Graphical presentation of core, aggregation and access devices. Table with brief textual description of the functions of each layer
Sources	http://www.cisco.com/en/US/docs/solutions/Enterprise/Data_Center/DC_Infra2_5/DCInfra_1.html
Module 1 Lesson 1 Topic 3 of 5	Core and Access Layers in a LAN Collapsed Core Design
Topic Objectives	Describe the reasons for combining the core and aggregation layers.
Media Treatment (Visuals)	Lecture using static slides
Content Types or Media Objects	Graphical presentation of combining core and aggregation layers. Table with brief textual description of the functions of each layer
Sources	http://www.cisco.com/en/US/docs/solutions/Enterprise/Borderless_Networks/Smart_Business_Architecture/SBA_Enterprise_BN_Collapsed_Core_Supplemental_H2CY10.pdf

Module 1 Lesson 1 Topic 4 of 5	Core and Edge Layers in a Data Center SAN Design
Topic Objectives	Describe the core and edge layers in a data center SAN design
Media Treatment (Visuals)	Lecture using static slides
Content Types or Media Objects	Graphical presentation of combining core and aggregation layers. Table with brief textual description of the functions of each layer
Sources	http://www.cisco.com/en/US/prod/collateral/modules/ps5991/prod_white_paper0900aecd8044c807_ps5990_Products_White_Paper.html

Module 1 Lesson 1 Topic 5 of 5	Collapsed Core SAN Design
Topic Objectives	Describe the reasons for combining the core and edge layers in a SAN design
Media Treatment (Visuals)	Lecture using static slides
Content Types or Media Objects	Graphical presentation of combining core and aggregation layers. Table with brief textual description of the functions of each layer
Sources	http://www.cisco.com/en/US/prod/collateral/modules/ps5991/prod_white_paper0900aecd8044c807_ps5990_Products_White_Paper.html

Module 1 Lesson 2 of 6 - Cisco Nexus Product Family.

Lesson Objective: Articulate the features of Cisco Nexus 7000, Nexus 5000, and Nexus 2000 products and their relationship to the layered design model.

Module 1 Lesson 2 Topic 1 of 15	Cisco Nexus Data Center Product Portfolio
Topic Objectives	Describe Cisco's goal of data center transformation with Cisco Nexus products.
Media Treatment (Visuals)	Lecture using static slides
Content Types or Media Objects	Graphical presentation of Nexus 7000, 5000, 2000 and 1000V. Bulleted text introducing high-level benefits of Nexus including scalability, performance, reliability and integration.
Sources	http://www.cisco.com/en/US/products/ps9441/Products_Sub_Category_Home.html#~three

Module 1 Lesson 2 Topic 2 of 15	Cisco Nexus 7000 Chassis Options
Topic Objectives	Describe the capacities of the Cisco Nexus 7000 Series chassis.
Media Treatment (Visuals)	Lecture using static slides
Content Types or Media Objects	Graphical presentation of Nexus 7009, 7010 and 7018 chassis. Table with port density and bandwidth supported by each switch. Show switch role in Core/Aggregation/Access hierarchy.
Sources	http://www.cisco.com/en/US/products/ps9402/products_data_sheets_list.html http://www.cisco.com/en/US/products/ps9402/index.html

Module 1 Lesson 2 Topic 3 of 15	Cisco Nexus 7000 Supervisor Modules
Topic Objectives	Describe the capabilities of the Cisco Nexus 7000 supervisor modules.
Media Treatment (Visuals)	Lecture using static slides
Content Types or Media Objects	Graphical presentation of supervisor modules in slots of 7009, 7010 and 7018 chassis. Bulleted list of supervisor roles and function.
Sources	http://www.cisco.com/en/US/prod/collateral/switches/ps9441/ps9402/ps9512/Data_Sheet_C78-437758.html

Module 1 Lesson 2 Topic 4 of 15	Cisco Nexus 7000 Switch Licensing Options
Topic Objectives	Describe licensing options for the Cisco Nexus Series switches
Media Treatment (Visuals)	Lecture using static slides
Content Types or Media Objects	Graphical presentation of licensing options Tables of license to feature mapping.
Sources	http://www.cisco.com/en/US/docs/switches/datacenter/sw/nx-os/licensing/guide/b_Cisco_NX-OS_Licensing_Guide.html

Module 1 Lesson 2 Topic 5 of 15	Cisco Nexus 7000 Switch Fabric Modules
Topic Objectives	Describe the capacities of the Cisco Nexus 7000 fabric modules.
Media Treatment (Visuals)	Lecture using static slides
Content Types or Media Objects	Graphical presentation of available bandwidth per fabric module. Table with slot BW available in each chassis..
Sources	http://www.cisco.com/en/US/prod/collateral/switches/ps9441/ps9402/ps9512/Data_Sheet_C78-437760.html http://www.cisco.com/en/US/prod/collateral/switches/ps9441/ps9402/ps9512/data_sheet_c78-684211_ps9402_Products_Data_Sheet.html

Module 1 Lesson 2 Topic 6 of 15	Cisco Nexus 7000 I/O Modules
Topic Objectives	Describe the capabilities of the Cisco Nexus 7000 I/O Modules.
Media Treatment (Visuals)	Lecture using static slides
Content Types or Media Objects	Graphical presentation of I/O Modules. Table with module features. Once slide for each module.
Sources	http://www.cisco.com/en/US/products/ps9402/products_data_sheets_list.html

Module 1 Lesson 2 Topic 7 of 15	Cisco Nexus 7000 Switch Power Supply Options
Topic Objectives	Describe the capabilities of the Cisco Nexus 7000 power supplies.
Media Treatment (Visuals)	Lecture using static slides
Content Types or Media Objects	Graphical presentation of power supplies. Table with power supply capabilities and number supported in each chassis. Power supply redundancy modes Screenshot of Cisco Power Calculator Link to Cisco Power Calculator: http://tools.cisco.com/cpc
Sources	http://www.cisco.com/en/US/prod/collateral/switces/ps9441/ps9402/ps9512/Data_Sheet_C78-437761_ps9402_Products_Data_Sheet.html

Module 1 Activity 1: Instructor Demo of Cisco Power Calculator (CPC)

Item	Description
Activity Objectives	Demonstrate the utility of the CPC to determine the number and model of power supplies
Activity Type	Specify: Demonstration
Visual Objective (Required for Lab)	Graphical Lab Topology
Required Resources	Internet access
Command List (Required for Lab)	Web Browser GUI
Activity Tasks	
Task	Objective
Browse to CPC URL	Demonstrate where to find the CPC
Login to CCO	CPC is a protected resource
Select switch	Select the switch model
Select line cards	Provide the CPC the information it needs to select the correct number of power supplies of a given model.
View redundancy modes	Validate that the PS combination supports the required redundancy mode.
Activity Verification	Learners have completed the activity when they have attained these results: Articulate the function of the CPC.

Module 1 Lesson 2 Topic 8 of 15	Cisco Nexus 5000 Series Chassis Options
Topic Objectives	Describe the Cisco Nexus 5000 and 5500 chassis.
Media Treatment (Visuals)	Lecture using static slides
Content Types or Media Objects	Graphical presentation of Nexus 5000 series power supplies. Table with fixed port count, BW and expansion slots.
Sources	http://www.cisco.com/en/US/products/ps9670/products_data_sheets_list.html

Module 1 Lesson 2 Topic 9 of 15	Cisco Nexus 5010 and 5020 Switch Features
Topic Objectives	Describe the Cisco Nexus 5010 and 5020 Series switches.
Media Treatment (Visuals)	Lecture using static slides
Content Types or Media Objects	Graphical presentation of Nexus 5010 and 5020. Table with fixed port count, BW and expansion slots. Where does the Nexus 5000 fit in the hierarchical LAN model?
Sources	http://www.cisco.com/en/US/products/ps9670/products_data_sheets_list.html

Module 1 Lesson 2 Topic 10 of 15	Cisco Nexus 5010 and 5020 Expansion Modules
Topic Objectives	Describe expansion modules available for the Cisco Nexus 5010 and 5020 Series switches.
Media Treatment (Visuals)	Lecture using static slides
Content Types or Media Objects	Graphical presentation of Nexus 5010 and 5020. Table with fixed port count, BW and expansion slots. Where does the Nexus 5000 fit in the hierarchical LAN model?
Sources	http://www.cisco.com/en/US/products/ps9670/products_data_sheets_list.html

Module 1 Lesson 2 Topic 11 of 15	Cisco Nexus 5500 Switch Features
Topic Objectives	Describe the Cisco Nexus 5548P, 5548UP, and 5596 Series switches
Media Treatment (Visuals)	Lecture using static slides
Content Types or Media Objects	Graphical presentation of Nexus 5548P, 5548UP, and 5596. Table with fixed port count, BW and expansion slots. Where does the Nexus 5500 fit in the hierarchical LAN model?
Sources	http://www.cisco.com/en/US/products/ps9670/products_data_sheets_list.html

Module 1 Lesson 2 Topic 12 of 15	Cisco Nexus 5500 Switch Series Expansion Modules
Topic Objectives	Describe the expansion modules available for Cisco Nexus 5548P, 5548UP, and 5596 Series switches
Media Treatment (Visuals)	Lecture using static slides
Content Types or Media Objects	Graphical presentation of Nexus 5548P, 5548UP, and 5596. Table with Module list and features.
Sources	http://www.cisco.com/en/US/prod/collateral/switches/ps9441/ps9670/data_sheet_c78-618603.html

Module 1 Lesson 2 Topic 13 of 15	Cisco Nexus 5000 Switch Series Software Licensing
Topic Objectives	Describe the software licensing for the Cisco Nexus 5000 Series switches
Media Treatment (Visuals)	Lecture using static slides
Content Types or Media Objects	Graphical presentation of Nexus 5548P, 5548UP, and 5596. Table with license to feature matrix.
Sources	http://www.cisco.com/en/US/prod/collateral/switches/ps9441/ps9670/data_sheet_c78-618603.html http://www.cisco.com/en/US/docs/switches/datacenter/sw/nx-os/licensing/guide/Cisco_NX-OS_Licensing_Guide_chapter1.html

Module 1 Lesson 2 Topic 14 of 15	Cisco Nexus 2000 Fabric Extender Function in the Cisco Data Center
Topic Objectives	Describe how the Cisco Nexus 2000 Fabric Extenders act as remote line modules
Media Treatment (Visuals)	Lecture using static slides
Content Types or Media Objects	Graphical presentation of Nexus 5548P, 5548UP, and 5596. Table with fixed port count, BW and expansion slots.
Sources	http://www.cisco.com/en/US/products/ps9670/products_data_sheets_list.html

Module 1 Lesson 2 Topic 15 of 15	Cisco Nexus 2000 Fabric Extender Features
Topic Objectives	Describe the Cisco Nexus 2000 Fabric Extenders
Media Treatment (Visuals)	Lecture using static slides
Content Types or Media Objects	Graphical presentation of Nexus 2148T, 2224TP, 2248TP and 2232PP fabric extenders. Table with server and fabric port count.
Sources	http://www.cisco.com/en/US/products/ps9670/products_data_sheets_list.html

Module 1 Lesson 3 of 6 - Cisco MDS Product Family.

Lesson Objective: Articulate the features of the Cisco Multilayer Director Switch (MDS) Fibre Channel switches and their relationship to the layered design model.

Module 1 Lesson 3 Topic 1 of 8	Cisco MDS 9000 Series Product Suite
Topic Objectives	Describe the data center benefits of deploying Cisco MDS 9000 Series switches.
Media Treatment (Visuals)	Lecture using static slides
Content Types or Media Objects	Graphical presentation of MDS 9506, 9509, 9513, and 9124, 9148, Fibre Channel and 9222i multiprotocol switches. Bulleted text introducing high-level benefits of MDS including scalability, performance, reliability and integration.
Sources	http://www.cisco.com/en/US/products/ps5990/products_data_sheets_list.html

Module 1 Lesson 3 Topic 2 of 8	Cisco MDS 9500 Series Chassis Options
Topic Objectives	Describe the capacities of the Cisco MDS 9500 Series switch chassis
Media Treatment (Visuals)	Lecture using static slides
Content Types or Media Objects	Graphical presentation of MDS 9506, 9509, 9513. Table with port density and bandwidth supported by each switch. Show switch role in Core/Edge hierarchy.
Sources	http://www.cisco.com/en/US/products/ps5990/products_data_sheets_list.html

Module 1 Lesson 3 Topic 3 of 8	Cisco MDS 9500 Series Supervisor Modules
Topic Objectives	Describe the capabilities of Cisco MDS 9500 Series switch supervisor modules
Media Treatment (Visuals)	Lecture using static slides
Content Types or Media Objects	Graphical presentation of supervisor modules in slots of MDS 9506,9509, 9513 chassis. Compare supervisor-2 and supervisor-2A. Bulleted list of supervisor roles and function.
Sources	http://www.cisco.com/en/US/products/ps5990/products_data_sheets_list.html

Module 1 Lesson 3 Topic 4 of 8	Cisco MDS 9500 Series Licensing Options
Topic Objectives	Describe licensing options for Cisco MDS 9000 switches.
Media Treatment (Visuals)	Lecture using static slides
Content Types or Media Objects	Graphical presentation of licensing options Tables of license to feature mapping.
Sources	http://www.cisco.com/en/US/products/ps5990/products_data_sheets_list.html

Module 1 Lesson 3 Topic 5 of 8	Cisco MDS 9500 Series I/O Modules
Topic Objectives	Describe the capabilities of the Cisco MDS 9500 Series I/O Modules
Media Treatment (Visuals)	Lecture using static slides
Content Types or Media Objects	Graphical presentation of I/O Modules. Table with module features. Once slide for each module. Cisco MDS 9000 Family 8-Gbps Advanced Fibre Channel Switching Modules Cisco MDS 9000 Family 8-Gbps Fibre Channel Switching Modules Cisco MDS 9000 Family 4-Port 10-Gbps Fibre Channel Switching Module Cisco MDS 9000 18/4-Port Multiservice Module Cisco MDS 9000 10-Gbps 8-Port FCoE Module
Sources	http://www.cisco.com/en/US/products/ps9402/products_data_sheets_list.html

Module 1 Lesson 3 Topic 6 of 8	Cisco MDS 9500 Series Power Supply Options
Topic Objectives	Describe the capabilities of MDS 9500 power supplies.
Media Treatment (Visuals)	Lecture using static slides
Content Types or Media Objects	Graphical presentation of power supply. Table with power supply capabilities. Power supply redundancy modes
Sources	http://www.cisco.com/en/US/partner/docs/storage/san_switches/mds9000/hw/9500series/installation/guide/install.html#wpmkr1313522

Module 1 Lesson 3 Topic 7 of 8	Cisco MDS 9100 Series Fabric Switches
Topic Objectives	Describe the capabilities of Cisco MDS 9100 Series fabric switches.
Media Treatment (Visuals)	Lecture using static slides
Content Types or Media Objects	Graphical presentation of Cisco 9100 edge switches. Table with model capabilities. Power supply redundancy modes
Sources	http://www.cisco.com/en/US/partner/docs/storage/san_switches/mds9000/hw/9500series/installation/guide/install.html#wpmkr1313522

Module 1 Lesson 3 Topic 8 of 8	Cisco MDS 9222i Multiprotocol Switch
Topic Objectives	Describe the capabilities of Cisco MDS 9222i switch.
Media Treatment (Visuals)	Lecture using static slides
Content Types or Media Objects	Graphical presentation of Cisco 9222i Multiprotocol Switch. Licensing options. Table with model capabilities. Power supply redundancy modes
Sources	http://www.cisco.com/en/US/partner/docs/storage/san_switches/mds9000/hw/9500series/installation/guide/install.html#wpmkr1313522

Module 1 Lesson 4 of 6 - Monitoring the Cisco Nexus 7000 and 5000 Series Switches

Lesson Objective: Perform an initial configuration and validate common features of the Cisco Nexus 7000 and 5000 Series switches.

Module 1 Lesson 4 Topic 1 of 9	Connecting to the Cisco Nexus 7000 and 5000 Series Switch Console Port
Topic Objectives	Describe the requirements to connect to the Cisco Nexus 7000 and 5000 Series switch console port
Media Treatment (Visuals)	Lecture using static slides
Content Types or Media Objects	Graphical presentation of the supervisor module and serial connector. Describe terminal requirements.
Sources	http://www.cisco.com/en/US/partner/docs/switches/datacenter/hw/nexus7000/cmp/configuration/guide/n7cmp.html

Module 1 Lesson 4 Topic 2 of 9	Running the Initial Setup Script for the Cisco Nexus 7000 and 5000 Series Switch
Topic Objectives	Describe the requirements of the Cisco Nexus 7000 and 5000 Series switch setup script
Media Treatment (Visuals)	Lecture using static slides
Content Types or Media Objects	Configuration flow chart. Text presentation of the steps in the command-line interface setup script.
Sources	http://www.cisco.com/en/US/docs/switches/datacenter/sw/5_x/nx-os/fundamentals/configuration/guide/Cisco_Nexus_7000_Series_NX-OS_Fundamentals_Configuration_Guide_Release_5.x_chapter3.html

Module 1 Lesson 4 Topic 3 of 9	Connecting to the Cisco Nexus 7000 Connectivity Management Processor (CMP)
Topic Objectives	Describe the requirements to connect to the Connectivity Management Processor on the Cisco Nexus 7000 Series switch
Media Treatment (Visuals)	Lecture using static slides
Content Types or Media Objects	Graphical presentation of the supervisor module and CMP Ethernet connector. Describe default Secure Shell (SSH) credentials to verify connectivity to the CMP.
Sources	http://www.cisco.com/en/US/partner/docs/switches/datacenter/hw/nexus7000/cmp/configuration/guide/n7cmp.html

Module 1 Activity 2: Instructor Demo of the Cisco Nexus 7000 Setup Script

Item	Description
Activity Objectives	Demonstrate initial setup of the Nexus 7000 using the setup script.
Activity Type	Specify: Demonstration
Visual Objective (Required for Lab)	Graphical Lab Topology
Required Resources	Internet access and access to a terminal server serial connection to the Nexus 7009 supervisor consoles.
Command List (Required for Lab)	Serial connection over TCP.
Activity Tasks	
Task	Objective
Reverse Telnet	Connect to the Nexus 7000 Supervisor Console via a terminal server connection.
Run setup	Configure the Nexus 7000 with basic setup to allow SSH access. Supply IP address, default gateway and netmask. Generate public and private RSA key pair to allow SSH. Save the configuration.
Activity Verification	Learners have completed the activity when they have attained these results: Articulate the steps required to perform initial setup of the Cisco Nexus 7000 switch.

Lab 1-1: Connect to the Cisco Nexus 7000 Using Secure Shell

Item	Description
Activity Objectives	Use Secure Shell client to access the Cisco Nexus 7000 switch to run various show commands
Activity Type	Specify: Lab Exercise
Visual Objective (Required for Lab)	Graphical Lab Topology
Required Resources	Internet access and SSH client.
Command List (Required for Lab)	<pre>show running-config interface mgmt 0 show running-config include route show ip route show ip route vrf management show interface mgmt. 0 brief show interface mgmt 0 ping <x.x.x.x> ping <x.x.x.x> vrf management</pre>
Activity Tasks	
Task	Objective
Secure Shell access	Use an SSH application to connect to the Nexus 7000 switch.
Explore management configuration and routing.	Use basic show commands to validate the management interface CLI.
Activity Verification	<p>Learners have completed the activity when they have attained these results:</p> <p>Validate the management interface configuration against a configuration sheet.</p> <p>Successfully ping the default gateway for the management vrf.</p>
Module 1 Lesson 4 Topic 4 of 9	Connecting to the Cisco Nexus Series Switch Using SSH to the Management VRF
Topic Objectives	Describe the requirements to Secure Shell to the management virtual routing and forwarding instance on the Cisco Nexus 7000 and 5000 Series switch
Media Treatment (Visuals)	Lecture using static slides
Content Types or Media Objects	Screenshot of SSH session.
Sources	

Module 1 Activity 3: Instructor Demo of the Cisco Nexus 5000 Setup Script

Item	Description
Activity Objectives	Demonstrate the initial setup of the Cisco Nexus 5500 switch using the setup script.
Activity Type	Specify: Demonstration
Visual Objective (Required for Lab)	Graphical Lab Topology
Required Resources	Internet access and access to a terminal server serial connection to the Cisco Nexus 5500 switch supervisor consoles.
Command List (Required for Lab)	Serial connection over TCP.
Activity Tasks	
Task	Objective
Reverse Telnet	Connect to the Nexus 5500 Supervisor Console via a terminal server connection.
Run setup	Configure the Nexus 5500 with basic setup to allow SSH access. Supply IP address, default gateway and netmask. Generate public and private RSA key pair to allow SSH. Save the configuration.
Activity Verification	Learners have completed the activity when they have attained these results: Articulate the steps required to perform initial setup of the Cisco Nexus 5500 switch.

Lab 1-2: Connect to the Cisco Nexus 5500 switch Using Secure Shell

Item	Description
Activity Objectives	Use a Secure Shell client to access the Cisco Nexus 5500 switch management interface.
Activity Type	Specify: Lab Exercise
Visual Objective (Required for Lab)	Graphical Lab Topology
Required Resources	Internet access and SSH client. Lab guide
Command List (Required for Lab)	show running-config interface mgmt 0 show running-config include route show ip route show ip route vrf management show interface mgmt. 0 brief show interface mgmt 0 ping <x.x.x.x> ping <x.x.x.x> vrf management
Activity Tasks	
Task	Objective
Secure Shell access	Use an SSH application to connect to the Cisco Nexus 5500 switch.
Explore management configuration and routing.	Use basic show commands to validate the management interface CLI.
Activity Verification	Learners have completed the activity when they have attained these results: Validate the management interface configuration against a configuration sheet. Successfully ping the default gateway for the management vrf.

Module 1 Lesson 4 Topic 5 of 9	ISSU on the Cisco Nexus 7000 and 5000 Series Switches
Topic Objectives	Describe the ISSU capabilities of the Cisco Nexus 7000 and 5000 Series switches
Media Treatment (Visuals)	Lecture using static slides
Content Types or Media Objects	Graphical representation of ISSU on Nexus 7000. Graphical representation of ISSU on Nexus 5000. Compare ISSU between 7000 and 5000.
Sources	http://www.cisco.com/en/US/docs/switches/datacenter/nexus5000/sw/upgrade/421_n2_1/Cisco_Nexus_5000_Series_NX-OS_Software_Upgrade_and_Downgrade_Guide_Release_421_chapter1.html http://www.cisco.com/en/US/docs/switches/datacenter/sw/5_x/nx-os/high_availability/configuration/guide/ha_issu.html

Module 1 Lesson 4 Topic 6 of 9	Verifying VLANs on the Cisco Nexus 7000 and 5000 Series Switches
Topic Objectives	Describe VLANs on the Cisco Nexus 7000 and 5000 Series switches
Media Treatment (Visuals)	Lecture using static slides
Content Types or Media Objects	Graphical representation of switch with no VLANs and one with VLANs. Text output of show VLAN command
Sources	

Module 1 Lesson 4 Topic 7 of 9	Operational Plane
Topic Objectives	Describe the control, management, and data planes on the Cisco Nexus 7000 and 5000 Series switches
Media Treatment (Visuals)	Lecture using static slides
Content Types or Media Objects	Graphical representation of Control, Management, and Data plane separation on the Nexus 7000 and 5000. Table describing the functions of each plane.
Sources	http://www.cisco.com/en/US/partner/docs/switches/datacenter/sw/6_x/nx-os/security/configuration/guide/Cisco_Nexus_7000_NX-OS_Security_Configuration_Guide__Release_6.x_chapter25.html#con_1067877

Module 1 Lesson 4 Topic 8 of 9	Cisco NX-OS Default Control Plane Policing
Topic Objectives	Describe CoPP on the Cisco Nexus 7000 and 5000 Series switches
Media Treatment (Visuals)	Lecture using static slides
Content Types or Media Objects	Graphical representation of control plane attacks against Nexus 7000 and 5000. ICMP IP Fragmentation TCP SYN Flooding
Sources	http://www.cisco.com/en/US/partner/docs/switches/datacenter/sw/6_x/nx-os/security/configuration/guide/Cisco_Nexus_7000_NX-OS_Security_Configuration_Guide__Release_6.x_chapter25.html#con_1067877

Module 1 Lesson 4 Topic 9 of 9	Important CLI Commands
Topic Objectives	Describe important CLI commands on the Cisco Nexus 7000 and 5000 Series switches
Media Treatment (Visuals)	Lecture using static slides
Content Types or Media Objects	Text output of command: show tech support Text output of command: show vlan Text output of command: show mac-address-table Text output of command: show interface Text output of command: show interface brief Text output of command: show version Text output of command: show ip route Text output of command: ping Text output of command: trace
Sources	http://www.cisco.com/en/US/partner/docs/switches/datacenter/sw/6_x/nx-os/security/configuration/guide/Cisco_Nexus_7000_NX-OS_Security_Configuration_Guide__Release_6.x_chapter25.html#con_1067877

Lab 1-3: Running CLI Commands

Item	Description
Activity Objectives	Use common CLI commands to validate a configuration on the Cisco Nexus 5000 switch.
Activity Type	Specify: Lab Exercise
Visual Objective (Required for Lab)	Graphical Lab Topology
Required Resources	Internet access and SSH client. Lab guide
Command List (Required for Lab)	<pre>show vlan show vlan summary show interface brief show interface trunk show mac address-table show mac address-table learning-mode show mac address-table vlan <x> show mac address-table aging-time show version show startup-config show running-config show running-config <feature> <all> show feature show tech-support show tech-support > volatile:<filename> show cdp neighbor show run vpc show tech vpc</pre>
Activity Tasks	
Task	Objective
Verify VLANs and VLAN Membership	Use the show commands to validate the VLAN and VLAN membership configuration
Verify interfaces	Use the show commands to verify which interfaces are operational
Verify the MAC address table	Use the show commands to verify the mac address table
Verify the Cisco NX-OS version	Use the show commands to verify which Cisco NX-OS version is running on the switch
Verify the configuration files	Use the show commands to verify the running and startup configuration files
Check for connectivity issues	Use the show commands to verify there are no connectivity issues
Activity Verification	<p>Learners have completed the activity when they have attained these results:</p> <ul style="list-style-type: none"> - verified the VLAN and VLAN membership - verified that interfaces are operational - verified the status of the MAC address table

Item	Description
	<ul style="list-style-type: none"> - verified which Cisco NX-OS version is running on the switches - verified the status of the configuration files - verified that there are no connectivity issues

Module 1 Lesson 5 of 6 - Describing Virtual Port Channels (vPC), and Cisco FabricPath in the Data Center

Lesson Objective: Articulate the utility of virtual Port Channels (vPCs), and Cisco FabricPath to interconnect data center switches.

Module 1 Lesson 5 Topic 1 of 4	Virtual Port Channels (vPC)
Topic Objectives	Describe Virtual Port Channels.
Media Treatment (Visuals)	Lecture using static slides
Content Types or Media Objects	<p>Graphical presentation of splitting a port channel across two switches.</p> <p>Graphical presentation of vPC topology on Nexus 7000 and 5000.</p> <p>Table with vPC interface role mapping.</p> <p>Describe load balancing methods for links in the port channel.</p> <p>Describe the effect on STP.</p>
Sources	http://www.cisco.com/en/US/partner/docs/switches/datacenter/sw/6_x/nx-os/interfaces/configuration/guide/if_portchannel.html

Module 1 Lesson 5 Topic 2 of 4	Verifying vPCs
Topic Objectives	Verify virtual Port Channels (vPC) on the Cisco Nexus 7000 and 5000 Series switches.
Media Treatment (Visuals)	Lecture using static slides
Content Types or Media Objects	<p>Table with vPC requirements.</p> <p>Text output of command: show vpc consistency-check</p> <p>Text output of command: show interface port-channel</p> <p>Describe the effect on STP.</p>
Sources	http://www.cisco.com/en/US/docs/switches/datacenter/sw/6_x/nx-os/interfaces/configuration/guide/if_cli.html

Lab 1-4: Configuring Virtual Port Channels

Item	Description
Activity Objectives	Connect to the Cisco Nexus 7000 Series and 5000 Series switches and perform the tasks required to configure and verify virtual port channels (vPC).
Activity Type	Specify: Lab Exercise
Visual Objective (Required for Lab)	Graphical Lab Topology
Required Resources	Internet access and SSH client. Lab guide
Command List (Required for Lab)	<pre> show interface description show interface brief show cdp neighbor show ip interface brief ping <x.x.x.x> feature vpc vpc domain n peer-keepalive destination <x.x.x.x> [source <x.x.x.x> vrf <vrf-name>] show running-config interface channel-group n [mode active] vpc peer-link description show port-channel summary show interface show vpc brief copy running-config startup-config vpc n show port-channel traffic show running-config vpc show tech-support vpc </pre>
Activity Tasks	
Task	Objective
Connect to your assigned switch	Establish a session with the switch you are assigned to configure.
Verifying Inter Switch Connections	Use CLI commands to verify the physical connections between the Cisco Nexus 7000 Series and Cisco Nexus 5000 Series switches.
Establish the VPC Domain	Configure and verify the VPC domain between the Cisco Nexus 7000 Series Switches.
Configure the Cisco Nexus 5000 Series Switch VPC's	Use CLI commands to configure and verify virtual port channels (VPC) on devices connected to the vpc domain.
Configure the Cisco Nexus 7000 Series Switch VPC's	Use CLI commands to configure and verify virtual port channels (VPC) on the switches that form the vpc domain.
Verify the Cisco Nexus 5000 Series Switch VPC's	Use CLI commands to verify virtual port channels (VPC) on devices connected to the vpc

Item	Description
	domain.
Activity Verification	Learners have completed the activity when they have attained these results: <ul style="list-style-type: none"> - You have verified port channel operation on the Cisco Nexus 5000 Series Switch. - You have verified traffic flow over the port channel interface.

Module 1 Lesson 5 Topic 3 of 4	Cisco FabricPath
Topic Objectives	Describe Cisco FabricPath on the Cisco Nexus 7000 and Nexus 5500 Series switches.
Media Treatment (Visuals)	Lecture using static slides
Content Types or Media Objects	Graphical presentation of FabricPath topology on Nexus 7000 and 5500 switches Bulleted list of FabricPath benefits. Table with FabricPath requirements. Table defining FabricPath terminology. Describe the effect on STP.
Sources	http://www.cisco.com/en/US/partner/docs/switches/datacenter/sw/6_x/nx-os/fabricpath/configuration/guide/fp_cli_Book.html

Module 1 Lesson 5 Topic 4 of 4	Verifying Cisco FabricPath
Topic Objectives	Verify Cisco FabricPath on the Cisco Nexus 7000 and 5500 Series switches
Media Treatment (Visuals)	Lecture using static slides
Content Types or Media Objects	Text output of command: show feature-set Text output of command: show mac address-table learning-mode Text output of command: show fabricpath conflict
Sources	http://www.cisco.com/en/US/partner/docs/switches/datacenter/sw/6_x/nx-os/fabricpath/configuration/guide/fp_cli_Book.html

Lab 1-5: Validate Cisco FabricPath Configuration

Item	Description
Activity Objectives	Validate the Cisco FabricPath configuration.
Activity Type	Specify: Lab Exercise
Visual Objective (Required for Lab)	Graphical Lab Topology
Required Resources	Internet access and SSH client. Lab guide
Command List (Required for Lab)	show feature-set show fabricpath switch-id show fabricpath isis adjacency show fabricpath route show mac address-table learning-mode show spanning-tree [vlan <x>] show cdp neighbor show fabricpath conflict all
Activity Tasks	
Task	Objective
Validate the Cisco FabricPath configuration	Use the show commands to validate a preloaded Cisco FabricPath configuration on the Cisco Nexus switches
Activity Verification	Learners have completed the activity when they have attained these results: - validate a preloaded Cisco FabricPath configuration on the Cisco Nexus switches

Module 1 Lesson 6 of 6 – Using OTV on Cisco Nexus 7000 Series Switches

Lesson Objective: Describe Overlay Transport Virtualization (OTV) as a method of Data Center Interconnect (DCI).

Module 1 Lesson 6 Topic 1 of 2	OTV on the Cisco Nexus 7000 Series Switch
Topic Objectives	Describe OTV on the Cisco Nexus 7000 Series switch
Media Treatment (Visuals)	Lecture using static slides
Content Types or Media Objects	Graphical presentation of data center connectivity before and after OTV. Graphical presentation of Control-Plane overlay Table describing OTV terminology (bind interface, join interface, et cetera) Hardware requirements and licensing.
Sources	http://www.cisco.com/en/US/docs/switches/datacenter/sw/nx-os/OTV/config_guide/b_Cisco_Nexus_7000_Series_NX-OS_OTV_Configuration_Guide.html
Module 1 Lesson 6 Topic 2 of 2	Verifying OTV on the Cisco Nexus 7000 Series Switch

Module 1 Lesson 6 Topic 1 of 2	OTV on the Cisco Nexus 7000 Series Switch
Topic Objectives	Verify OTV on the Cisco Nexus 7000 Switch
Media Treatment (Visuals)	Lecture using static slides
Content Types or Media Objects	Graphical presentation of OTV connecting two sites. Text output of command: show otv overlay Text output of command: show otv datagroup Text output of command: show otv vlan Text output of command: show otv site Text output of command: show otv adjacency
Sources	http://www.cisco.com/en/US/docs/switches/datacenter/sw/nx-os/OTV/config_guide/b_Cisco_Nexus_7000_Series_NX-OS_OTV_Configuration_Guide.html

Lab 1-6: Validate OTV

Item	Description
Activity Objectives	Validate a preloaded OTV configuration.
Activity Type	Specify: Lab Exercise
Visual Objective (Required for Lab)	Graphical Lab Topology
Required Resources	Internet access and SSH client. Lab guide
Command List (Required for Lab)	show license usage show otv overlay 1 show vlan show otv adjacency show otv route ping <x.x.x.x> show otv arp-nd-cache
Activity Tasks	
Task	Objective
Validate a Cisco OTV configuration	Use the show commands to validate an OTV configuration that has been preloaded on to the Cisco Nexus 7000 switches
Activity Verification	Learners have completed the activity when they have attained these results: - validate a preloaded OTV configuration on the Cisco Nexus 7000 switches

Module 2 of 5: Cisco Data Center Virtualization

Module Objective: Describe the functions and benefits of Cisco Data Center virtualization.

Module 2 Lesson 1 of 5 - Virtualizing Network Devices

Lesson Objective: Describing the virtualization capabilities of the Cisco Nexus 7000 and 5000 Series data center switches.

Module 2 Lesson 1 Topic 1 of 4	Virtual Device Contexts on the Cisco Nexus 7000 Series Switch
Topic Objectives	Describe VDCs on the Cisco Nexus 7000 Series switches.
Media Treatment (Visuals)	Lecture using static slides
Content Types or Media Objects	Graphical presentation of Nexus 7000 before and after configuring VDCs. Table of bulleted text describing the features and benefits of VDCs. Describe interface allocation to a VDC. Describe licensing requirements.
Sources	http://www.cisco.com/en/US/docs/switches/datacenter/sw/5_x/nx-os/virtual_device_context/quick/guide/b_Cisco_Nexus_7000_Series_NX-OS_Virtual_Device_Context_Quick_Start.html http://www.cisco.com/en/US/docs/switches/datacenter/sw/nx-os/virtual_device_context/configuration/guide/vdc_nx-os_cfg.html

Module 2 Lesson 1 Topic 2 of 4	Verifying VDCs on the Cisco Nexus 7000 Series Switch
Topic Objectives	Verify VDCs on the Cisco Nexus 7000 Series switch.
Media Treatment (Visuals)	Lecture using static slides
Content Types or Media Objects	Graphical presentation of Nexus 7000 with three VDCs. Text output of command: show feature-set Text output of command: show running-config vdc-all Text output of command: show vdc Text output of command: show vdc membership
Sources	http://www.cisco.com/en/US/docs/switches/datacenter/sw/5_x/nx-os/virtual_device_context/command/reference/vdc_commands.html

Module 2 Lesson 1 Topic 3 of 4	Navigating Between VDCs on the Cisco Nexus 7000 Series Switch
Topic Objectives	Describe how to navigate between VDCs on the Cisco Nexus 7000 Series switch.
Media Treatment (Visuals)	Lecture using static slides
Content Types or Media Objects	Graphical presentation of Nexus 7000 with three VDCs. Graphical presentation indicating navigation from default VDC to child VDCs and inability for child VDCs to access default VDC Text output of command: switchto vdc Text output of command: switchback
Sources	http://www.cisco.com/en/US/docs/switches/datacenter/sw/5_x/nx-os/virtual_device_context/command/reference/vdc_commands.html

Lab 2-1: Verify the Current VDC Settings

Item	Description
Activity Objectives	Validate the current VDC configuration.
Activity Type	Specify: Lab Exercise
Visual Objective (Required for Lab)	Graphical Lab Topology
Required Resources	Internet access and SSH client. Lab guide
Command List (Required for Lab)	show vdc show vdc detail show vdc feature-set show vdc internal mac-address-table show vdc membership
Activity Tasks	
Task	Objective
Verify the VDC settings	Use the show commands to verify the settings that are configured for a VDC
Activity Verification	Learners have completed the activity when they have attained these results: - validated a preloaded VDC configuration and checked that the settings are correct

Module 2 Lesson 1 Topic 4 of 4	Network Interface Virtualization on the Cisco Nexus 7000 and 5000 Series Switches
Topic Objectives	Describe NIV on the Cisco Nexus 7000 and 5000 Series switch.
Media Treatment (Visuals)	Lecture using static slides
Content Types or Media Objects	Graphical presentation of Nexus 7000 and 5000 switches with Nexus 2000 satellites. Graphical representation illustrating fabric ports and server ports. Graphical presentation illustrating the 'hair-pin turn' and the need for loop-avoidance. Graphical presentation of VNTag fields and where it is inserted in a packet. Text output of command: show module Text output of command: show module fex Text output of command: show interface
Sources	http://www.cisco.com/en/US/docs/switches/datacenter/sw/5_x/nx-os/interfaces/command/reference/if_commands.html#wp2047441

Note Although FEXs can be installed on Nexus 7000 and 5000, the examples will be on Nexus 55548UP.

Lab 2-2: Validate the Cisco Nexus 2000 FEX Configuration

Item	Description
Activity Objectives	Validate the Cisco Nexus 2000 Fabric Extender configuration.
Activity Type	Specify: Lab Exercise
Visual Objective (Required for Lab)	Graphical Lab Topology
Required Resources	Internet access and SSH client. Lab guide
Command List (Required for Lab)	show fex show run interface Ethernet 1/x-y show fex detail show running-config fex all show interface Ethernet 1/x fex-intf show interface brief show module fex #
Activity Tasks	
Task	Objective
Validate the Cisco Nexus 2000 FEX configuration	Use the show commands to validate a preloaded Cisco Nexus 2000 FEX configuration on the Cisco Nexus 5000 switch
Activity Verification	Learners have completed the activity when they have attained these results: - validated a preloaded Cisco Nexus 2000 FEX configuration

Module 2 Lesson 2 of 5 - Virtualizing Storage

Lesson Objective: Describe how storage is virtualized for high availability and configuration flexibility.

Module 2 Lesson 2 Topic 1 of 2	LUN Storage Virtualization
Topic Objectives	Describe logical disk partitions.
Media Treatment (Visuals)	Lecture using static slides
Content Types or Media Objects	Graphical comparison of logical disk partitions versus LUNs. Table describing the difference between a partition and a LUN.
Sources	http://en.wikipedia.org/wiki/Raid_levels

Module 2 Lesson 2 Topic 2 of 2	Storage System Virtualization
Topic Objectives	Describe how storage controllers can virtualize the backend storage from multiple vendors for a single point of management.
Media Treatment (Visuals)	Lecture using static slides
Content Types or Media Objects	Graphical representation generic storage virtualization. Table describing the benefits of storage virtualization.
Sources	http://media.netapp.com/documents/ds-3111.pdf

Module 2 Lesson 3 of 5 - Virtualizing Server Solutions

Lesson Objective: Describing the benefits of server virtualization in the Data Center.

Module 2 Lesson 3 Topic 1 of 2	Benefits of Server Virtualization
Topic Objectives	Describe the benefits of server consolidation in the Cisco Data Center
Media Treatment (Visuals)	Lecture using static slides
Content Types or Media Objects	Graphical representation of the host-based virtualization and hypervisor-based virtualization. Table describing the difference between virtualization approaches. Graphical representation of server farms before virtualization. Describe the poor utilization before consolidation. Graphical representation of server farms after virtualization. Describe the utilization after consolidation.
Sources	http://www.vmware.com/solutions/cost-savings

Module 2 Lesson 3 Topic 2 of 2	Data Center Server Virtualization Solutions
Topic Objectives	Describe available data center server virtualization solutions
Media Treatment (Visuals)	Lecture using static slides
Content Types or Media Objects	Graphical representation of the VMware, Red Hat, Microsoft hypervisor-based virtualization. Describe unique selling propositions. Compare Hypervisor OS support.
Sources	Adapt from DCUCI 4.0

Module 2 Lesson 4 of 5 - Using the Cisco Nexus 1000V Switch

Lesson Objective: Describe problems solved by Cisco Nexus 1000v and how the Virtual Supervisor Module (VSM) and Virtual Ethernet Module (VEM) integrate with VMware ESX and vCenter.

Module 2 Lesson 4 Topic 1 of 4	Limitations of the VMware vSwitch
Topic Objectives	Describe the limitations of the VMware vSwitch.
Media Treatment (Visuals)	Lecture using static slides
Content Types or Media Objects	Graphical presentation of the function and need for a switch in the hypervisor. Describe limitations of the vSwitch.
Sources	Adapt from DCUCI 4.0

Module 2 Lesson 4 Topic 2 of 4	Advantages of the VMware vNetwork Distributed Switch
Topic Objectives	Describe the Advantages of the VMware vNetwork Distributed Switch
Media Treatment (Visuals)	Lecture using static slides
Content Types or Media Objects	Graphical comparison of vSwitch vs vDS. Describe benefits of single point of management and consistency of policy.
Sources	Adapt from DCUCI 4.0

Module 2 Lesson 4 Topic 3 of 4	How the Cisco Nexus 1000V Switch Brings Network Visibility to the Virtual Machine Level
Topic Objectives	Describe how the Cisco Nexus 1000V switch takes network visibility to the virtual machine level
Media Treatment (Visuals)	Lecture using static slides

Module 2 Lesson 4 Topic 3 of 4	How the Cisco Nexus 1000V Switch Brings Network Visibility to the Virtual Machine Level
Content Types or Media Objects	Graphical presentation of server and LAN team separation of duties before server virtualization. Describe clear delineation of duties. Graphical presentation of server and LAN team separation of duties after server virtualization. Describe muddled delineation of duties. Describe the benefits of a Cisco Nexus 1000V implementation.
Sources	Adapt from DCUCI 4.0

Module 2 Lesson 4 Topic 4 of 4	How the VSM and VEM Integrate with VMware ESX or ESXi and vCenter
Topic Objectives	Describe how the VSM and VEM integrate with VMware ESX or ESXi and vCenter
Media Treatment (Visuals)	Lecture using static slides
Content Types or Media Objects	Graphical representation of VSM and VEM in a VMware environment. Table describing the function of VSM and VEM (management, control and data planes). Graphical representation of port profile creation, push to vCenter and consumption by the server admin.
Sources	Adapt from DCUCI 4.0 http://www.vmware.com/files/pdf/VMW_09Q1_WP_vSphereNetworking_P8_R1.pdf http://www.cisco.com/en/US/docs/switches/datacenter/nexus1000/sw/4_0_4_s_v_1_3/getting_started/configuration/guide/n1000v_gsg.html

Module 2 Lesson 5 of 5 - Verifying Setup and Operation of the Cisco Nexus 1000v Switch

Lesson Objective: Use the VMware ESX CLI console and the Cisco Nexus 1000v VSM to validate connectivity of VSM to VEMs and vCenter.

Module 2 Lesson 5 Topic 1 of 3	Verify the initial configuration and module status on the Cisco Nexus 1000V
Topic Objectives	Identify the commands that are used to verify the initial configuration and module status on the Cisco Nexus 1000V
Media Treatment (Visuals)	Lecture using static slides
Content Types or Media Objects	Graphical presentation of accessing the ESX service console. Graphical presentation of accessing the ESXi Troubleshooting Mode CLI. Text output of the command: vem status.
Sources	Adapt from DCUCI 4.0

Module 2 Lesson 5 Topic 2 of 3	Identifying how to verify the VEM status on the ESX or ESXi host
Topic Objectives	Identify how to verify the VEM status on the ESX or ESXi host
Media Treatment (Visuals)	Lecture using static slides
Content Types or Media Objects	Graphical presentation of navigating to VEM status in the VMware vCenter GUI.
Sources	Adapt from DCUCI 4.0

Module 2 Lesson 5 Topic 3 of 3	Identifying how to validate Virtual Machine port groups
Topic Objectives	Identify how to validate Virtual Machine port groups
Media Treatment (Visuals)	Lecture using static slides
Content Types or Media Objects	Text output of command: show modules.
Sources	Adapt from DCUCI 4.0

Lab 2-3: Validate the Cisco Nexus 1000v Configuration

Item	Description
Activity Objectives	Validate the Cisco Nexus 1000v configuration.
Activity Type	Specify: Lab Exercise
Visual Objective (Required for Lab)	Graphical Lab Topology
Required Resources	Internet access and SSH client. Lab Guide
Command List (Required for Lab)	show module show port-profile show port-profile brief show port-profile name <name> show port-profile usage show running-config show svcs domain show svcs connection show interface Ethernet x/y show interface vethernet x
Activity Tasks	
Task	Objective
Validate the Cisco Nexus 1000V configuration	Use the show commands to validate a preloaded Cisco Nexus 1000V configuration
Activity Verification	Learners have completed the activity when they have attained these results: - validated a preloaded Cisco Nexus 1000V configuration using the show commands

Module 3 of 5: Cisco Data Center Storage Networking

Module Objective: Describe the function of Cisco Data Center storage networking technologies and verify correct operation.

Module 3 Lesson 1 of 3 - Comparing Storage Connectivity Options in the Data Center

Lesson Objective: Compare Internet Small Computer Systems Interconnect (iSCSI), Fibre Channel, and Network Attached Storage (NAS) connectivity for remote server storage.

Module 3 Lesson 1 Topic 1 of 3	Comparing Block and File-Based Network Storage
Topic Objectives	Compare the NAS and SAN approaches to network storage.
Media Treatment (Visuals)	Lecture using static slides
Content Types or Media Objects	Graphical presentation of File and block based network storage. Table or bulleted list of characteristics.
Sources	

Module 3 Lesson 1 Topic 2 of 3	NFS, Fibre Channel, iSCSI and SCSI
Topic Objectives	Describe the NFS, Fibre Channel, iSCSI and SCSI protocols for transporting data between servers and remote storage devices.
Media Treatment (Visuals)	Lecture using static slides
Content Types or Media Objects	Graphical of NFS packet format. Graphical of iSCSI packet format. Graphical of Fibre Channel packet format. Describe the function of FC HBA's and iSCSI TCP Offload Engines (TOE) on performance.
Sources	http://en.wikipedia.org/wiki/Scsi Adapt from ICSNS

Module 3 Lesson 1 Topic 3 of 3	SCSI Evolution from DAS to SAN
Topic Objectives	Describe the evolution of SCSI from Direct Attached Storage to SAN
Media Treatment (Visuals)	Lecture using static slides
Content Types or Media Objects	Graphical presentation of direct-attach SCSI storage cable limitations. Graphical presentation of bus-length restriction and bus termination. Describe limitation of DAS SCSI.
Sources	http://en.wikipedia.org/wiki/Scsi

Module 3 Lesson 2 of 3 - Describing Fibre Channel Storage Networking

Lesson Objective: Explain the Fibre Channel topologies and how communication is established between an initiator and target device on the SAN

Module 3 Lesson 2 Topic 1 of 6	Fibre Channel SAN Topologies
Topic Objectives	Describe Fibre Channel SAN topologies
Media Treatment (Visuals)	Lecture using static slides
Content Types or Media Objects	Graphical presentation of point to point, arbitrated loop and switched topologies. Describe the benefits and use cases of each topology.
Sources	Adapt from DCUCI 4.0. Fast Lane DCNX5K Module 4 Lesson 1: The Fibre Channel Protocol

Module 3 Lesson 2 Topic 2 of 6	Fibre Channel Port Types
Topic Objectives	Describe Fibre Channel port types
Media Treatment (Visuals)	Lecture using static slides
Content Types or Media Objects	Graphical presentation of Fibre Channel switched topology with port types labeled. Table of complementary port types.
Sources	Adapt from Fast Lane DCNX5K Module 4 Lesson 1: The Fibre Channel Protocol

Module 3 Lesson 2 Topic 3 of 6	Fibre Channel Addressing
Topic Objectives	Describe Fibre Channel addressing
Media Treatment (Visuals)	Lecture using static slides
Content Types or Media Objects	Graphical presentation of Fibre Channel addresses on a dual-port CNA. Describe the IEEE WWN formats and OUI.
Sources	Adapt from Fast Lane DCNX5K Module 4 Lesson 1: The Fibre Channel Protocol

Module 3 Lesson 2 Topic 4 of 6	Fibre Channel Layered Model
Topic Objectives	Describe the Fibre Channel layered model
Media Treatment (Visuals)	Lecture using static slides
Content Types or Media Objects	Graphical presentation of Fibre Channel layers. Describe the each layer.
Sources	Adapt from Fast Lane DCNX5K Module 4 Lesson 1: The Fibre Channel Protocol

Module 3 Lesson 2 Topic 5 of 6	Fibre Channel Name Server and Fabric Login Process
Topic Objectives	Describe the Fibre Channel Name Server and fabric login process
Media Treatment (Visuals)	Lecture using static slides
Content Types or Media Objects	Graphical presentation of Fibre Channel FLOGI, PLOGI and PRLI and interaction with the name server. Describe the login process and how after receiving a Fibre Channel Identifier (FCID) the method of connecting to another Fibre Channel endpoint.
Sources	Adapt from Fast Lane DCNX5K Module 4 Lesson 1: The Fibre Channel Protocol

Module 3 Lesson 2 Topic 6 of 6	Fibre Channel Zoning and LUN Masking
Topic Objectives	Describe the use of Fibre Channel zoning and logical unit number masking
Media Treatment (Visuals)	Lecture using static slides
Content Types or Media Objects	Graphical presentation of Fibre Channel initiators and targets before Zoning. Graphical presentation of Fibre Channel initiators and targets after Zoning. Describe where zoning is configured and what it accomplishes. Graphical presentation of storage controller before LUN Masking. Graphical presentation of storage controller after LUN Masking. Describe where LUN Masking is configured and what it accomplishes.
Sources	Adapt from Fast Lane DCNX5K Module 4 Lesson 1: The Fibre Channel Protocol

Module 3 Lesson 3 of 3 - Verifying Fibre Channel Communications on Cisco MDS Switches

Lesson Objective: Perform an initial configuration of a Cisco MDS 9000 Series Fibre Channel switch and use various show commands

Module 3 Lesson 3 Topic 1 of 6	Configure an Cisco MDS 9000 Series Switch from the CLI Setup Script
Topic Objectives	Configure a Cisco MDS 9000 Series switch from the CLI setup script
Media Treatment (Visuals)	Lecture using static slides
Content Types or Media Objects	Connect to the serial console of an MDS 9124 and enter the setup script. Configure basic settings and demonstrate SSH connection to the configured MDS.
Sources	http://www.cisco.com/en/US/docs/switches/datacenter/mds9000/sw/4_1/configuration/guides/cli_4_1/icfg.html#wpxref97856

Module 3 Activity 1: Instructor Demo of the Cisco MDS 9100 Setup Script

Item	Description
Activity Objectives	Demonstrate initial setup of the the Cisco MDS 9100 using the setup script.
Activity Type	Specify: Demonstration
Visual Objective (Required for Lab)	Graphical Lab Topology
Required Resources	Internet access and access to a terminal server serial connection to the MDS 9124 console.
Command List (Required for Lab)	Serial connection over TCP.
Activity Tasks	
Task	Objective
Reverse Telnet	Connect to the MDS 9100 Console via a terminal server connection.
Run setup	Configure the MDS 9100 with basic setup to allow SSH access. Supply IP address, default gateway and netmask. Generate public and private RSA key pair to allow SSH. Save the configuration.
Activity Verification	Learners have completed the activity when they have attained these results: Articulate the steps required to perform initial setup of the Cisco MDS 9100

Module 3 Lesson 3 Topic 2 of 6	Update the Cisco NX-OS on a Cisco MDS 9000 Series switch
Topic Objectives	Update a Cisco MDS 9000 Series switch from the CLI setup script
Media Treatment (Visuals)	Lecture using static slides
Content Types or Media Objects	Connect to the MDS 9124 with SSH. Copy operating system files to flash memory. Describe how to use the install all command to update NX-OS. Describe how to use the show version command to verify the version.
Sources	http://www.cisco.com/en/US/docs/switches/datacenter/mds9000/sw/5_2/command/reference/cr4_2x.html

Module 3 Lesson 3 Topic 3 of 6	Update Licensed Features on the Cisco MDS 9000 Series Switch
Topic Objectives	Update licensed features on a Cisco MDS 9000 Series switch
Media Treatment (Visuals)	Lecture using static slides
Content Types or Media Objects	Connect to the MDS 9124 with SSH. Copy license files to flash memory. Describe how to use the install license command to update licensed features. Describe how to use the show license command to verify features.
Sources	http://www.cisco.com/en/US/docs/switches/datacenter/mds9000/sw/5_2/command/reference/cr4_2x.html

Lab 3-1: Validate the Cisco MDS 9100 Switch License

Item	Description
Activity Objectives	Validate MDS 9124 feature licenses against a configuration worksheet.
Activity Type	Specify: Lab Exercise
Visual Objective (Required for Lab)	Graphical Lab Topology
Required Resources	Internet access and SSH client. Lab guide
Command List (Required for Lab)	show license show license usage show license default show license host-id
Activity Tasks	
Task	Objective
Validate the license and features	Use the show commands to validate the license and features used on the Cisco MDS 9100 switch
Activity Verification	Learners have completed the activity when they have attained these results: - validated the license and features of the Cisco MDS 9100 switch

Module 3 Lesson 3 Topic 4 of 6	Verify Initiator and Target Fabric Login
Topic Objectives	Verify initiator and target fabric login
Media Treatment (Visuals)	Lecture using static slides
Content Types or Media Objects	Describe how to use the show flogi database command to view initiators and targets logged into the MDS 9124. Describe how to use the show version command to verify features.
Sources	http://www.cisco.com/en/US/docs/switches/datacenter/mds9000/sw/5_2/command/reference/cr4_2x.html

Module 3 Lesson 3 Topic 5 of 6	Verify Fibre Channel Zoning on a Cisco MDS 9000 Series Switch
Topic Objectives	Verify Fibre Channel zoning on a Cisco MDS 9000 Series switch
Media Treatment (Visuals)	Lecture using static slides
Content Types or Media Objects	<p>Describe how to use the show zone command to verify initiators are zoned to their target.</p> <p>Describe how to use the show zone active command to determine if initiator and target are logged into the fabric.</p> <p>Describe how to use the show zoneset active command to view the active set of configured zones.</p> <p>Describe how to use the show device-alias command to view the alias mapping of World-Wide Names.</p>
Sources	http://www.cisco.com/en/US/docs/switches/datacenter/mds9000/sw/5_2/command/reference/cr4_2x.html

Lab 3-2: Configuring VSANs and Zoning

Item	Description
Activity Objectives	Configure VSANs and zoning on the Cisco Nexus 5000 Series switch and the Cisco MDS 9100 Series switch
Activity Type	Specify: Lab Exercise
Visual Objective (Required for Lab)	Graphical Lab Topology
Required Resources	Internet access and SSH client. Lab guide
Command List (Required for Lab)	<pre> show module show interface brief show interface description show ip interface brief [vrf vrf-name] show ip interface ping <x.x.x.x>[vrf vrf-name] ping <x.x.x.x> show feature show vsan show vlan id n show vlan fcoe n vsan database vsan n vsan n name VSAN-name show vsan membership vsan n interface <interface slot/port> copy running-config startup-config switchport trunk allowed vsan n show zone policy show zone active show zoneset active show device-alias database zone name name vsan n member device-alias device-alias-name show zone zoneset name zoneset-name vsan n member zone-name zoneset activate name zoneset-name vsan n show zone status vsan n show zoneset </pre>
Activity Tasks	
Task	Objective
Connect to your assigned switch	Establish a session with the switch you are assigned to configure.
Verifying Inter Switch Connections	Use CLI commands to verify the physical connections between the Cisco Nexus 7000 Series and Cisco Nexus 5000 Series switches.
Verifying Lab Connections	Use CLI commands to verify the physical

Item	Description
	connections between the servers, the Cisco Nexus 5000 Series and Cisco MDS 9100 Series switches.
Configure VSANs on the Cisco Nexus 5000 Series Switch	Use the CLI commands to configure VSANs and assign Fibre Channel interfaces into the correct VSANs to complete the pre-loaded FCoE configuration of the Cisco Nexus 5000 Series switch.
Configure VSANs on the Cisco MDS Series Switch	Use the CLI commands to configure VSANs and assign Fibre Channel interfaces into the correct VSANs to complete the pre-loaded configuration of the Cisco MDS 9100 Series switch.
Optimizing VSAN Trunking	Use the CLI commands to optimize VSAN trunking, minimizing the traffic utilizing a trunk connection.
Verify the Default Zoning	Use CLI commands to verify the default zoning configuration of the switches.
Configuring Zoning	Use CLI commands to configure and verify the zone set and active zone set of the fabric on the Cisco MDS 9100 Series switch.
Activity Verification	<p>Learners have completed the activity when they have attained these results:</p> <ul style="list-style-type: none"> - You have verified that the device-alias database is present on the switches - You have configured a zone for each server and its storage devices - You have configured a zone set that contains all configured zones - You have verified that the active zone set has been distributed across the fabric and is visible on the other switches.

Lab 3-3: Validate Fabric Login and Fibre Channel Name Services

Item	Description
Activity Objectives	Describe how to verify that initiators and targets have been able to successfully log in to the fabric. Describe how to verify Fibre Channel Name Services to ensure that devices have registered with the fabric.
Activity Type	Specify: Lab Exercise
Visual Objective (Required for Lab)	Graphical Lab Topology
Required Resources	Internet access and SSH client. Lab guide
Command List (Required for Lab)	show flogi database show fcns database
Activity Tasks	
Task	Objective
Validate initiator and target connectivity to the fabric	Use the show commands to verify that initiators and targets have been able to successfully log in to the fabric
Validate the zone configuration	Use the show commands to validate that initiators can see their target devices
Activity Verification	Learners have completed the activity when they have attained these results: <ul style="list-style-type: none"> - You have successfully verified that devices have been able to login and register in the fabric. - You have displayed the databases that contain the login and fabric information
Module 3 Lesson 3 Topic 6 of 6	Collect Tech Support Data on a Cisco MDS 9000 Series Switch
Topic Objectives	Collect tech support data on a Cisco MDS 9000 Series switch
Media Treatment (Visuals)	Lecture using static slides
Content Types or Media Objects	Describe how to use the show tech support command and various CLI options to collect support data for the Cisco TAC.
Sources	http://www.cisco.com/en/US/docs/switches/datacenter/mds9000/sw/5_2/command/reference/cr4_2x.html

Lab 3-4: View the Tech-Support Output

Item	Description
Activity Objectives	Observe the output of the show tech-support command on the Cisco MDS.
Activity Type	Specify: Lab Exercise
Visual Objective (Required for Lab)	Graphical Lab Topology
Required Resources	Internet access and SSH client Lab guide
Command List (Required for Lab)	show tech-support show tech-support brief show tech-support bootvar show tech-support details show tech-support device-alias show tech-support license
Activity Tasks	
Task	Objective
View the tech-support output	Use the show commands to view different tech-support outputs that would be used when verifying connectivity
Activity Verification	Learners have completed the activity when they have attained these results: - successfully viewed the tech-support outputs and piped the details to a file

Module 4 of 5: Cisco Data Center Unified Fabric

Module Objective: Articulate the function of Cisco Data Center Unified Fabric technologies and verify correct operation.

Module 4 Lesson 1 of 3 - Describing Data Center Bridging

Lesson Objective: Describe Data Center Bridging (DCB) and the IEEE standards that allow for a lossless Fibre Channel fabric to be transported over Ethernet.

Module 4 Lesson 1 Topic 1 of 5	Unified Fabric Benefits
Topic Objectives	Describe the benefits of a Unified Fabric and the FCoE Protocol
Media Treatment (Visuals)	Lecture using static slides
Content Types or Media Objects	Graphical presentation of server connectivity before and after unified fabric. Describe the reduced per server cable count.
Sources	Adapt from Fast Lane N5k course.

Module 4 Lesson 1 Topic 2 of 5	IEEE Standards that Enable Fibre Channel over Ethernet
Topic Objectives	Describe the IEEE Standards that enable Fibre Channel over Ethernet and the FIP Protocol
Media Treatment (Visuals)	Lecture using static slides
Content Types or Media Objects	Table with name and definitions of Priority Flow Control (PFC), Enhanced Transmission Selection (ETS), Congestion Management, and Data Center Bridging eXchange (DCBx).
Sources	Adapt from DCUCI 4.0.

Module 4 Lesson 1 Topic 3 of 5	Priority Flow Control
Topic Objectives	Describe Priority Flow Control
Media Treatment (Visuals)	Lecture using static slides
Content Types or Media Objects	Graphical presentation comparing classical Ethernet Pause and PFC per-priority pause. Graphical presentation 802.1p header and three CoS bits. Describe how per-priority pause allows for lossless Ethernet fabric.
Sources	Adapt from Fast Lane N5k course.

Module 4 Lesson 1 Topic 4 of 5	Enhanced Transmission Selection
Topic Objectives	Describe Enhanced Transmission Selection
Media Treatment (Visuals)	Lecture using static slides
Content Types or Media Objects	Graphical presentation of per-priority bandwidth allocation. Describe how per-priority bandwidth allocation allows enforcement of a lossless Ethernet fabric.
Sources	Adapt from Fast Lane N5k course.

Module 4 Lesson 1 Topic 5 of 5	Data Center Bridging eXchange
Topic Objectives	Describe Data Center Bridging eXchange
Media Treatment (Visuals)	Lecture using static slides
Content Types or Media Objects	Graphical presentation of FCF communication to determine capabilities. Wireshark output of DCBx Logical Link Discovery Protocol (LLDP) exchanges
Sources	Adapt from Fast Lane N5k course.

Module 4 Lesson 2 of 3 – Connectivity Options for FCoE on the Cisco Nexus 5000 Series Switch

Lesson Objective: Identify connectivity options for connecting the Converged Network Adapter (CNA) to the Cisco Nexus 5000 switch and the switch to upstream LAN and SAN environments.

Module 4 Lesson 2 Topic 1 of 4	Small Form-Factor Pluggable Modules
Topic Objectives	Describe small form-factor pluggable modules
Media Treatment (Visuals)	Lecture using static slides
Content Types or Media Objects	Graphical presentation of SFP, SFP+ optical, SFP+ twinax and GLC-1T. Describe the basic characteristics of SFP, SFP+, SFP+ Twinax and GLC-1T.
Sources	http://www.cisco.com/en/US/prod/collateral/switchehes/ps9441/ps9670/data_sheet_c78-618603.html

Module 4 Lesson 2 Topic 2 of 4	Cable Requirements and Distance Limitations for Common SFP and SFP+ Transceivers
Topic Objectives	Describe cabling requirements and distance limitations for common SFP and enhanced SFP transceivers
Media Treatment (Visuals)	Lecture using static slides
Content Types or Media Objects	Table comparing the distance limitations and optical or copper cable requirements. Include SFP, SFP+, SFP+ Twinax and GLC-1T.
Sources	http://www.cisco.com/en/US/prod/collateral/switchehes/ps9441/ps9670/data_sheet_c78-618603.html http://www.cisco.com/en/US/prod/collateral/modules/ps5455/data_sheet_c78-455693.html

Module 4 Lesson 2 Topic 3 of 4	Connecting the Cisco P81E Virtualization Interface Card to Cisco Nexus 5500UP Unified Fabric Switches
Topic Objectives	Connect the Cisco P81E virtualization interface card to the Cisco Nexus 5500UP Unified fabric switch
Media Treatment (Visuals)	Lecture using static slides
Content Types or Media Objects	Graphical presentation of connections for Fabric A and Fabric B. Graphical representation of LAN on Motherboard (LOM) connections for Out of Band (OOB) management connection to C-Series chassis.
Sources	Adapt from DCUCI 4.0

Module 4 Lesson 2 Topic 4 of 4	Connecting the Cisco Nexus 5500UP Unified Fabric Switches to Northbound LAN and SAN Fabrics
Topic Objectives	Connect the Cisco Nexus 5500UP Unified fabric switch to northbound LAN and SAN Fabrics
Media Treatment (Visuals)	Lecture using static slides
Content Types or Media Objects	Graphical presentation of LAN connections for Fabric A and Fabric B. Graphical presentation of SAN connections for Fabric A and Fabric B. Review distinct transceiver requirements for LAN versus SAN.
Sources	Adapt from DCUCI 4.0

Lab 4-1: Validate Physical Connections for FCoE

Item	Description
Activity Objectives	Use show commands to validate physical connectivity necessary for FCoE.
Activity Type	Specify: Lab Exercise
Visual Objective (Required for Lab)	Graphical Lab Topology Lab guide
Required Resources	Internet access and SSH client.
Command List (Required for Lab)	show interface brief show interface Ethernet x/y show interface Ethernet x/y transceiver show interface Ethernet x/y status show interface Ethernet x/y fcoe show interface vfc x
Activity Tasks	
Task	Objective
Verify the physical connectivity for FCoE connections	Use the show commands to verify the physical connectivity required for FCoE connections
Activity Verification	Learners have completed the activity when they have attained these results: - validated the physical connectivity requirements for FCoE connections

Module 4 Lesson 3 of 3 - Describing Enhanced FCoE Scalability with the Cisco Nexus 2232 Fabric Extender

Lesson Objective: Describe the role of NIV with the Cisco Nexus 2232 Fabric Extender in FCoE deployments.

Module 4 Lesson 3 Topic 1 of 4	Scaling the Data Center Virtualized Access Layer with the Cisco Nexus 2000 Fabric Extender
Topic Objectives	Describe how the Cisco Nexus 2232 Fabric Extender increases scalability of FCoE deployments
Media Treatment (Visuals)	Lecture using static slides
Content Types or Media Objects	Graphical presentation Cisco Nexus 2232 fanning out to 32 FCoE servers. Describe additional scalability potential.
Sources	http://www.cisco.com/en/US/prod/collateral/switces/ps9441/ps10110/data_sheet_c78-507093.html

Module 4 Lesson 3 Topic 2 of 4	Cisco Nexus 2232 Fabric Extender to Cisco Nexus 5500 Switch Connectivity
Topic Objectives	Describe the Cisco Nexus 2232 Fabric Extender connectivity to the Cisco Nexus 5500 Series switch
Media Treatment (Visuals)	Lecture using static slides
Content Types or Media Objects	Graphical presentation Cisco Nexus 2232 fabric and server connections. Describe bandwidth oversubscription.
Sources	Adapt from DCUCI 4.0

Module 4 Lesson 3 Topic 3 of 4	Adapter FEX with the Cisco Nexus 2232 Fabric Extender
Topic Objectives	Describe adapter FEX with the Cisco Nexus 2232 Fabric Extender
Media Treatment (Visuals)	Lecture using static slides
Content Types or Media Objects	Graphical presentation of Cisco Nexus 2232 Network Interface Virtualization (NIV). Describe bandwidth oversubscription.
Sources	http://www.cisco.com/en/US/solutions/collateral/ns340/ns517/ns224/ns945/ns1134/ns1118/data_sheet_c78_657397.pdf

Module 4 Lesson 3 Topic 4 of 4	Verifying Adapter FEX with the Cisco Nexus 2232 Fabric Extender
Topic Objectives	Verify adapter FEX with the Cisco Nexus 2232 Fabric Extender
Media Treatment (Visuals)	Lecture using static slides
Content Types or Media Objects	Describe how to use the show fex command to view fabric extender operational state. Describe how to use the show fex detail command to view detailed state of attached fabric extenders and satellite ports.
Sources	http://www.cisco.com/en/US/solutions/collateral/ns340/ns517/ns224/ns945/ns1134/ns1118/data_sheet_c78_657397.pdf

Module 5 of 5: Cisco Unified Computing System

Module Objective: Articulate and verify correct operation of the components, connectivity and management of Cisco Unified Computing Systems.

Module 5 Lesson 1 of 6 - Cisco UCS B-Series Product Family

Lesson Objective: Describe the components of Cisco UCS B-Series.

Module 5 Lesson 1 Topic 1 of 8	Cisco UCS 6100 and 6200 series Fabric Interconnects
Topic Objectives	Describe fabric interconnect options
Media Treatment (Visuals)	Lecture using static slides
Content Types or Media Objects	Graphical presentation of Fabric Interconnect models. Graphical presentation of Fabric Interconnect expansion modules. Describe the number of ports available. Describe Unified Ports.
Sources	Adapt from DCUCI 4.0

Module 5 Lesson 1 Topic 2 of 8	Cisco UCS 5108 Blade Server Chassis
Topic Objectives	Describe the Cisco UCS 5108 Blade Server Chassis.
Media Treatment (Visuals)	Lecture using static slides
Content Types or Media Objects	Graphical presentation of Cisco UCS 5108 Blade Server Chassis. Graphical presentation of Cisco UCS 5108 Blade Server Chassis power supplies. Graphical presentation of Cisco UCS 2104XL and 2208XL Input/Output Modules (IOMs). Describe the number of ports available. Describe Unified Ports.
Sources	Adapt from DCUCI 4.0

Module 5 Lesson 1 Topic 3 of 8	Cisco UCS B200-M2 Blade Server
Topic Objectives	Describe the Cisco UCS B200-M2 Blade Server.
Media Treatment (Visuals)	Lecture using static slides
Content Types or Media Objects	Graphical presentation of Cisco UCS B200-M2 Blade Server. Describe CPU options. Describe local hard drive options and RAID. Describe memory capacity
Sources	Adapt from DCUCI 4.0 and product data sheets. http://www.cisco.com/en/US/products/ps10280/rod_models_home.html

Module 5 Lesson 1 Topic 4 of 8	Cisco UCS B230-M2 Blade Server
Topic Objectives	Describe the Cisco UCS B230-M2 Blade Server.
Media Treatment (Visuals)	Lecture using static slides
Content Types or Media Objects	Graphical presentation of Cisco UCS B230-M2 Blade Server. Describe CPU options. Describe local hard drive options and RAID. Describe memory capacity
Sources	Adapt from DCUCI 4.0 and product data sheets.

Module 5 Lesson 1 Topic 5 of 8	Cisco UCS B250-M2 Blade Server
Topic Objectives	Describe the Cisco UCS B250-M2 Blade Server.
Media Treatment (Visuals)	Lecture using static slides
Content Types or Media Objects	Graphical presentation of Cisco UCS B250-M2 Blade Server. Describe CPU options. Describe local hard drive options and RAID. Describe memory capacity
Sources	Adapt from DCUCI 4.0 and product data sheets.

Module 5 Lesson 1 Topic 6 of 8	Cisco UCS B440-M2 Blade Server
Topic Objectives	Describe the Cisco UCS B440-M2 Blade Server.
Media Treatment (Visuals)	Lecture using static slides
Content Types or Media Objects	Graphical presentation of Cisco UCS B440-M2 Blade Server. Describe CPU options. Describe local hard drive options and RAID. Describe memory capacity
Sources	Adapt from DCUCI 4.0 and product data sheets.

Module 5 Lesson 1 Topic 7 of 8	Mezzanine Card Options for B-Series Blade Servers
Topic Objectives	Describe the features of B-Series mezzanine cards.
Media Treatment (Visuals)	Lecture using static slides
Content Types or Media Objects	Graphical presentation of the following adapters: Cisco UCS CNA M72KR-E Emulex Converged Network Adapter Cisco UCS CNA M72KR-Q QLogic Converged Network Adapter Cisco UCS CNA M61KR-I Intel Converged Network Adapter Cisco UCS M71KR-E Emulex Converged Network Adapter Cisco UCS M71KR-Q QLogic Converged Network Adapter Cisco UCS NIC M51KR-B Broadcom BCM57711 Network Adapter Cisco UCS 82598KR-CI 10 Gigabit Ethernet Adapter Describe the features of each adapter.
Sources	Adapt from DCUCI 4.0 and adaptor data sheets. http://www.cisco.com/en/US/products/ps10280/products_data_sheets_list.html

Module 5 Lesson 1 Topic 8 of 8	Memory Population Guidelines for B-Series Blade Servers
Topic Objectives	Describe the best practices for populating DRAM in the B-Series Blades.
Media Treatment (Visuals)	Lecture using static slides
Content Types or Media Objects	Graphical presentation of the following server motherboards: B200-M2 B230-M2 B250-M2 B440-M2 Describe balanced and non-balanced memory configurations. Describe CPU requirements to populate memory.
Sources	Adapt from DCUCI 4.0 and adaptor data sheets. UCS Processor and Memory Cheatsheet v3.1.pdf

Module 5 Lesson 2 of 6 - Cisco UCS C-Series Product Family

Lesson Objective: Describe the components of Cisco UCS C-Series product family.

Module 5 Lesson 2 Topic 1 of 11	Cisco C-Series Product Family
Topic Objectives	Describe the Cisco C-Series Product Family
Media Treatment (Visuals)	Lecture using static slides
Content Types or Media Objects	Graphical presentation of C-Series Product Family. At a high-level, describe the goal of C-Series servers in standalone and UCS Manager integration mode.
Sources	Adapt from DCUCI 4.0

Module 5 Lesson 2 Topic 2 of 11	Cisco UCS C200-M2 Rack Server
Topic Objectives	Describe the Cisco UCS C200-M2 Rack Server.
Media Treatment (Visuals)	Lecture using static slides
Content Types or Media Objects	Graphical presentation of Cisco UCS C200-M2 Rack Server. Describe CPU options. Describe local hard drive options and RAID. Describe memory capacity
Sources	Adapt from DCUCI 4.0 and product data sheets.

Module 5 Lesson 2 Topic 3 of 11	Cisco UCS C210-M2 Rack Server
Topic Objectives	Describe the Cisco UCS C210-M2 Rack Server.
Media Treatment (Visuals)	Lecture using static slides
Content Types or Media Objects	Graphical presentation of Cisco UCS C210-M2 Rack Server. Describe CPU options. Describe local hard drive options and RAID. Describe memory capacity
Sources	Adapt from DCUCI 4.0 and product data sheets.

Module 5 Lesson 2 Topic 4 of 11	Cisco UCS C220-M2 Rack Server
Topic Objectives	Describe the Cisco UCS C220-M2 Rack Server.
Media Treatment (Visuals)	Lecture using static slides
Content Types or Media Objects	Graphical presentation of Cisco UCS C220-M2 Rack Server. Describe CPU options. Describe local hard drive options and RAID. Describe memory capacity
Sources	Adapt from DCUCI 4.0 and product data sheets.

Module 5 Lesson 2 Topic 5 of 11	Cisco UCS C240-M2 Rack Server
Topic Objectives	Describe the Cisco UCS C240-M2 Rack Server.
Media Treatment (Visuals)	Lecture using static slides
Content Types or Media Objects	Graphical presentation of Cisco UCS C240-M2 Rack Server. Describe CPU options. Describe local hard drive options and RAID. Describe memory capacity
Sources	Adapt from DCUCI 4.0 and product data sheets.

Module 5 Lesson 2 Topic 6 of 11	Cisco UCS C250-M2 Rack Server
Topic Objectives	Describe the Cisco UCS C250-M2 Rack Server.
Media Treatment (Visuals)	Lecture using static slides
Content Types or Media Objects	Graphical presentation of Cisco UCS C250-M2

Module 5 Lesson 2 Topic 6 of 11	Cisco UCS C250-M2 Rack Server
	Rack Server. Describe CPU options. Describe local hard drive options and RAID. Describe memory capacity
Sources	Adapt from DCUCI 4.0 and product data sheets.

Module 5 Lesson 2 Topic 7 of 11	Cisco UCS C260-M2 Rack Server
Topic Objectives	Describe the Cisco UCS C260-M2 Rack Server.
Media Treatment (Visuals)	Lecture using static slides
Content Types or Media Objects	Graphical presentation of Cisco UCS C260-M2 Rack Server. Describe CPU options. Describe local hard drive options and RAID. Describe memory capacity
Sources	Product data sheet. http://www.cisco.com/en/US/products/ps11588/index.html

Module 5 Lesson 2 Topic 8 of 11	Cisco UCS C460-M2 Rack Server
Topic Objectives	Describe the Cisco UCS C460-M2 Rack Server.
Media Treatment (Visuals)	Lecture using static slides
Content Types or Media Objects	Graphical presentation of Cisco UCS C460-M2 Rack Server. Describe CPU options. Describe local hard drive options and RAID. Describe memory capacity
Sources	Adapt from DCUCI 4.0 and product data sheets.

Module 5 Lesson 2 Topic 9 of 11	PCIe Adapter Options for C-Series Rack Servers
Topic Objectives	Describe the features of B-Series mezzanine cards.
Media Treatment (Visuals)	Lecture using static slides
Content Types or Media Objects	Graphical presentation of the following adapters: BCM95709A0906G - Quad port 10/100/1000Mbps x4 PCI Cisco UCS P81E Virtual Interface Card (VIC) Dual Port 10Gbps Enhanced Ethernet to PCIe Dual Port, 4Gbps Fibre Channel-to-PCI Express Host Bus Adapter Intel® Ethernet Server Adapter X520-DA2 (Dual port 10Gbps) Intel® Gigabit ET2 Quad Port Server Adapter Low profile dual port 10Gbps FCoE converged adapter Quad Port Gb ET Server Adapter 4Gbps Fibre Channel PCI Express Host Bus Adapters Describe the features of each adapter.
Sources	Adapt from DCUCI 4.0 and adaptor data sheets. http://www.cisco.com/en/US/products/ps10493/products_data_sheets_list.html

Module 5 Lesson 2 Topic 10 of 11	RAID Adapter Options for C-Series Rack Servers
Topic Objectives	Describe RAID adapter options for C-Series rack servers.
Media Treatment (Visuals)	Lecture using static slides
Content Types or Media Objects	Graphical presentation of the following adapters: Intel ICH10R LSI 1064E LSI MegaRAID SAS 9240-8i LSI MegaRAID 9260-4i LSI MegaRAID SAS 9260-8i LSI MegaRAID 9280-4i4e LSI MegaRAID 9261-8i Describe the features of each adapter and model restrictions.
Sources	Adapt from DCUCI 4.0 and adaptor data sheets. http://www.cisco.com/en/US/products/ps10493/products_data_sheets_list.html

Module 5 Lesson 2 Topic 11 of 11	Memory Population Guidelines for C-Series Rack Servers
Topic Objectives	Describe the best practices for populating DRAM in the C-Series Rack Servers.
Media Treatment (Visuals)	Lecture using static slides
Content Types or Media Objects	Graphical presentation of the following server motherboards: C200-M2 C210-M2 C210-M2 C250-M2 C260-M2 C460-M2 Describe balanced and non-balanced memory configurations. Describe CPU requirements to populate memory.
Sources	Adapt from DCUCI 4.0 and product data sheets. UCS Processor and Memory Cheatsheet v3.1.pdf

Module 5 Lesson 3 of 6 - Cisco UCS B-Series Connectivity

Lesson Objective: Describe how Cisco UCS B-Series servers connect to the chassis and achieve external LAN and SAN connectivity.

Module 5 Lesson 3 Topic 1 of 5	Chassis- to-Fabric Interconnect Physical Connectivity
Topic Objectives	Describe the options for connecting a blade server chassis to the fabric interconnects.
Media Treatment (Visuals)	Lecture using static slides
Content Types or Media Objects	Graphic depicting one, two, and four uplinks from the fabric interconnect to the 2104XL I/O module and the resulting oversubscription. Graphic depicting up to eight uplinks from the fabric interconnect to the 2208XL I/O module and the resulting oversubscription. Graphic depicting port channel from the fabric interconnect to the 2208XL I/O module and the resulting oversubscription.
Sources	Adapt from DCUCI 4.0 and product data sheets. Adapt from Capitola NPI.
Module 5 Lesson 3 Topic 2 of 5	I/O Module Architectures
Topic Objectives	Describe how physical connections from the fabric interconnect to the I/O module are routed to the various internal components of the blade servers.
Media Treatment (Visuals)	Lecture using static slides
Content Types or Media Objects	Graphic of 2104XP I/O module connectivity Graphic of 2208XP I/O module connectivity Redundant traces across the midplane for data plane and management planes connectivity Chassis management controller Chassis management switch Redwood I/O multiplexer
Sources	Adapt from DCUCI 4.0. Gai S., Salli, T., et al (2009). Project California: a Data Center Virtualization Server. Raleigh, NC: Lulu.Com.

Module 5 Lesson 3 Topic 3 of 5	Cisco Integrated Management Controller Chip on B-Series Blades
Topic Objectives	Describe the three main features of the baseboard management controller.
Media Treatment (Visuals)	Lecture using static slides
Content Types or Media Objects	Photo of B-200 blade is a clear marker to the BMC component on the motherboard KVM over IP IPMI over IP serial over LAN
Sources	Adapt from DCUCI 4.0. Gai S., Salli, T., et al (2009). Project California: a Data Center Virtualization Server. Raleigh, NC: Lulu.Com.

Module 5 Lesson 3 Topic 4 of 5	Three Basic Port Personalities in the Fabric Interconnect
Topic Objectives	Describe the three basic states a 10 Gigabit Ethernet interface can be configured on the fabric interconnect.
Media Treatment (Visuals)	Lecture using static slides
Content Types or Media Objects	Screenshot of Cisco UCS Manager depicting how to select the port personality for a 10 GE interfaces on the fabric interconnect LAN Uplinks Manager
Sources	Adapt from DCUCI 4.0.

Module 5 Lesson 3 Topic 5 of 5	Discovery Process
Topic Objectives	Describe the discovery process and how to monitor using Finite State Machine (FSM) output
Media Treatment (Visuals)	Lecture using static slides
Content Types or Media Objects	Graphic depicting chassis discovery, blade discovery, and subcomponents welcome to Managed Objects Finite State Machine Chassis discovery policy Blade discovery policy
Sources	Adapt from DCUCI 4.0.

Module 5 Lesson 4 of 6 - Configuring Cisco UCS B-Series Initial Cluster Setup

Lesson Objective: Describe the required information necessary to perform initial B-Series cluster setup and validate cluster operation.

Module 5 Lesson 4 Topic 1 of 4	Cabling a UCS 6100 Fabric Interconnect Cluster
Topic Objectives	Describe the required physical connectivity to create a fabric interconnect cluster.
Media Treatment (Visuals)	Lecture using static slides
Content Types or Media Objects	Graphical presentation physical cabling with descriptive text.
Sources	Adapt from DCUCI 4.0 Appendix A

Module 5 Lesson 4 Topic 2 of 4	Initial Setup Script for the Primary Peer
Topic Objectives	Describe the information needed to configure the primary cluster peer.
Media Treatment (Visuals)	Lecture using static slides
Content Types or Media Objects	Output of the setup script.
Sources	Adapt from DCUCI 4.0 Appendix A

Module 5 Lesson 4 Topic 3 of 4	Initial Setup Script for the Secondary Peer
Topic Objectives	Describe the information needed to configure the secondary cluster peer.
Media Treatment (Visuals)	Lecture using static slides
Content Types or Media Objects	Output of the setup script.
Sources	Adapt from DCUCI 4.0 Appendix A

Module 5 Lesson 4 Topic 4 of 4	Verify Fabric Interconnect Cluster
Topic Objectives	Verify that normal cluster communications and roles have been established.
Media Treatment (Visuals)	Lecture using static slides
Content Types or Media Objects	Output of the setup script.
Sources	Adapt from DCUCI 4.0 Appendix A

Module 5 Activity 1: Instructor Demo of Cisco UCS 6120 Fabric Interconnect Setup Script

Item	Description
Activity Objectives	Demonstrate initial setup of the UCS 6120 Fabric Interconnect using the setup script.
Activity Type	Specify: Demonstration
Visual Objective (Required for Lab)	Graphical Lab Topology
Required Resources	Internet access and access to a terminal server serial connection to the UCS 6120 Fabric Interconnect consoles.
Command List (Required for Lab)	Serial connection over TCP.
Activity Tasks	
Task	Objective
Reverse Telnet	Connect to the UCS 6120 Fabric Interconnect Console via a terminal server connection.
Run setup	Configure the UCS 6120 Fabric Interconnect with basic setup to allow HTTP and SSH access. Supply IP address, default gateway and netmask. Generate public and private RSA key pair to allow SSH. Save the configuration.
Activity Verification	Learners have completed the activity when they have attained these results: Articulate the steps required to perform initial setup of the UCS 6120 Fabric Interconnect.

Module 5 Lesson 5 of 6 - Cisco UCS Manager

Lesson Objective: Describe how Cisco UCS Manager discovers new hardware, manages and monitors all UCS components.

Module 5 Lesson 5 Topic 1 of 5	Cisco Unified Computing System Manager
Topic Objectives	Describe the functions of UCS Manager
Media Treatment (Visuals)	Lecture using static slides
Content Types or Media Objects	Graphical presentation of UCS Manager GUI and CLI. Describe the XML database that stores configuration and state data. Describe how UCS Manager communicates with components through application gateways.
Sources	Adapt from DCUCI 4.0

Module 5 Lesson 5 Topic 2 of 5	Layout of the UCS Manager GUI
Topic Objectives	Describe the basic layout of UCS Manager
Media Treatment (Visuals)	Lecture using static slides
Content Types or Media Objects	Screenshot of Cisco UCS Manager GUI Navigation pane Content pane Breadcrumb Trail.
Sources	Adapt from DCUCI 4.0

Module 5 Lesson 5 Topic 3 of 5	Navigation Window Tabs
Topic Objectives	Describe which configuration elements are configured under the six tabs of the navigation pane.
Media Treatment (Visuals)	Lecture using static slides
Content Types or Media Objects	Screenshots of each of the six navigation tabs Equipment tab Servers tab LAN tab SAN tab VM tab (not in pre-Aptos releases) Admin tab
Sources	Adapt from DCUCI 4.0

Module 5 Lesson 5Topic 4 of 5	Device Discovery in UCS Manager
Topic Objectives	Describe how components are discovered by UCS Manager.
Media Treatment (Visuals)	Lecture using static slides
Content Types or Media Objects	Flow chart of chassis discovery. Describe how a chassis, IOM, blade servers and their components are enumerated by UCS Manager
Sources	Adapt from DCUCI 4.0

Module 5 Lesson 5Topic 5 of 5	Verifying Device Discovery in UCS Manager
Topic Objectives	Verify Device Discovery in UCS Manager
Media Treatment (Visuals)	Lecture using static slides
Content Types or Media Objects	Describe which components in UCS are subject to FSM validation. Describe where to observe FSM transactions.
Sources	Adapt from DCUCI 4.0

Module 5 Activity 2: Instructor Demo of Configuring Server Ports and Chassis Discovery

Item	Description
Activity Objectives	Demonstrate chassis discovery.
Activity Type	Specify: Demonstration
Visual Objective (Required for Lab)	Graphical Lab Topology
Required Resources	Internet access and access and web browser.
Command List (Required for Lab)	Serial connection over TCP.
Activity Tasks	
Task	Objective
UCSM Login	Login to UCS Manager.
Configure Server ports to the IOMs	<p>Configure the appropriate ports on the 6120 fabric interconnects as server ports.</p> <p>Demonstrate Chassis discovery by monitoring the Finite State Machine.</p> <p>Demonstrate how the chassis link policy requires a re-acknowledgement of the chassis to use all four links.</p> <p>Demonstrate Hybrid Display to sho all physical and backplane connections.</p>
Activity Verification	<p>Learners have completed the activity when they have attained these results:</p> <p>Articulate the steps required to connect a Cisco UCS 5108 chassis to the UCS 6120 Fabric Interconnects.</p>

Lab 5-1: Explore the Cisco UCS Manager GUI

Item	Description
Activity Objectives	Navigate through the UCS Manager GUI.
Activity Type	Specify: Lab exercise
Visual Objective (Required for Lab)	Graphical Lab Topology
Required Resources	Internet access and web browser.
Command List (Required for Lab)	Web GUI.
Activity Tasks	
Task	Objective
Activity Verification	Learners have completed the activity when they have attained these results:

Module 5 Lesson 6 of 6 - Cisco UCS Manager Pools, Policies, Templates, and Service Profiles

Lesson Objective: Describe features of Cisco UCS Manager that allow for rapid provisioning and consistent application of policy.

Module 5 Lesson 6 Topic 1 of 5	Benefits of Stateless Computing
Topic Objectives	Describe how the abstraction of hardware identities allows fast server mobility from one compute node to another.
Media Treatment (Visuals)	Lecture using static slides
Content Types or Media Objects	Graphical presentation of server mobility. Describe the Cisco UCS Service Profile and its components.
Sources	Adapt from DCUCI 4.0

Module 5 Lesson 6 Topic 2 of 5	Using Identity Pools in Service Profiles
Topic Objectives	Describe how pooled resources ensure uniqueness of identities assigned to Service Profiles.
Media Treatment (Visuals)	Lecture using static slides
Content Types or Media Objects	Graphical presentation of UUID, MAC Address, WWNN, and WWPN pools. Describe the expert Service Profile wizard and how to apply a pooled identity.
Sources	Adapt from DCUCI 4.0

Module 5 Lesson 6 Topic 3 of 5	Using Service Profile Templates to Enable Rapid Provisioning and Consistent Application of Policy
Topic Objectives	Describe how Service Profile Templates allow rapid scaling of Cisco UCS.
Media Treatment (Visuals)	Lecture using static slides
Content Types or Media Objects	Graphical presentation of Service Profile Templates using UUID, MAC Address, WWNN, WWPN, and server pools. Describe the Service Profile Template wizard and demonstrate creating a web server farm.
Sources	Adapt from DCUCI 4.0

Module 5 Lesson 6 Topic 4 of 5	Creation of Policies for Service Profiles and Service Profile Templates
Topic Objectives	Describe creating policies that map to service profiles and templates.
Media Treatment (Visuals)	Lecture using static slides
Content Types or Media Objects	Graphical presentation creating adapter policies and binding them to Service Profiles and Service Profile.
Sources	Adapt from DCUCI 4.0

Module 5 Lesson 6 Topic 5 of 5	Chassis and Blade Power Capping
Topic Objectives	Describe creating chassis and blade power capping policies.
Media Treatment (Visuals)	Lecture using static slides
Content Types or Media Objects	Graphical presentation creating adapter policies and binding them to Service Profiles and Service Profile.
Sources	Adapt from DCUCI 4.0

Note I recommend Power Capping be dropped as it is really a design consideration that should be deferred to the CCNP DC courseware.

Lab 5-2: Configure a Service Profile Template from Pre-Configured Identity and Resource Pools

Item	Description
Activity Objectives	Configure a service profile template and spawn service profiles from the template.
Activity Type	Specify: Lab exercise
Visual Objective (Required for Lab)	Graphical Lab Topology
Required Resources	Internet access and web browser.
Command List (Required for Lab)	Web GUI.
Activity Tasks	
Task	Objective
Activity Verification	Learners have completed the activity when they have attained these results:

