



<https://t.me/learningnets>



PROJECT

ENG

PRO

CYBER SECURITY FOR INDUSTRIAL CONTROL SYSTEMS

By Project **ENG PRO**



Programmable Logic Controllers Introduction



In this lesson, we will delve into the topic of Programmable Logic Controllers (PLCs) and gain a comprehensive understanding of their overview and functionality.

Allen Bradley PLC



ControlNet



Profibus

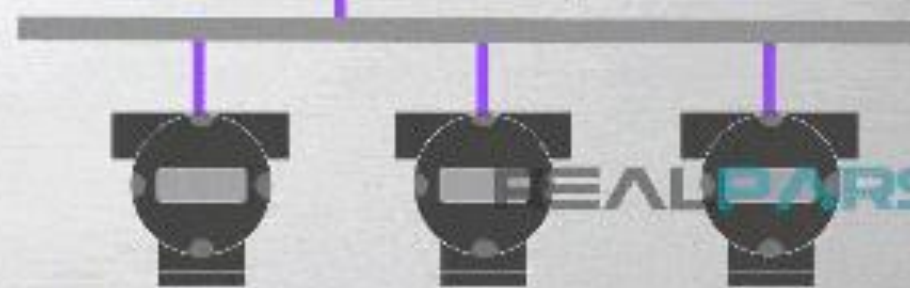

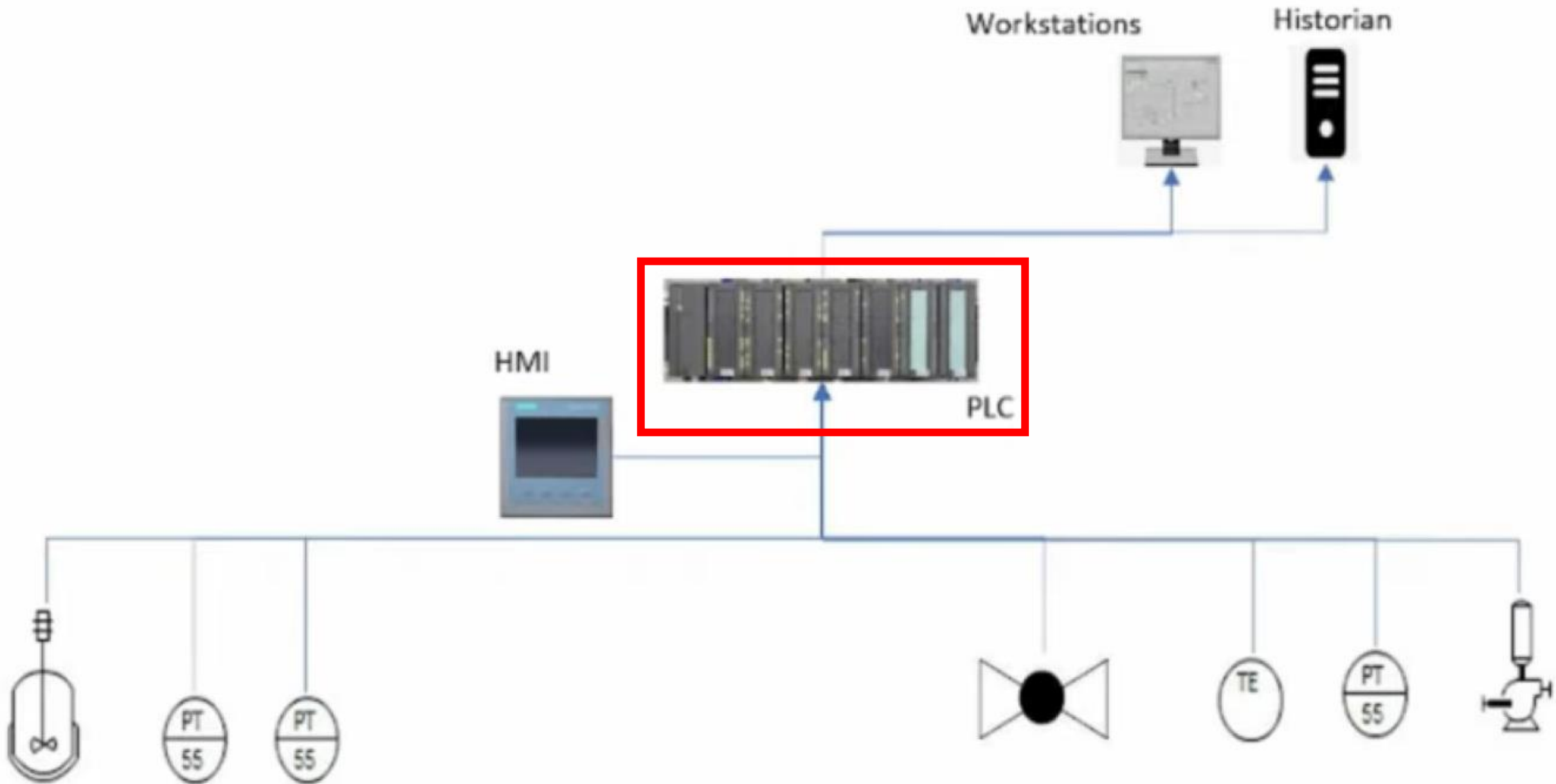

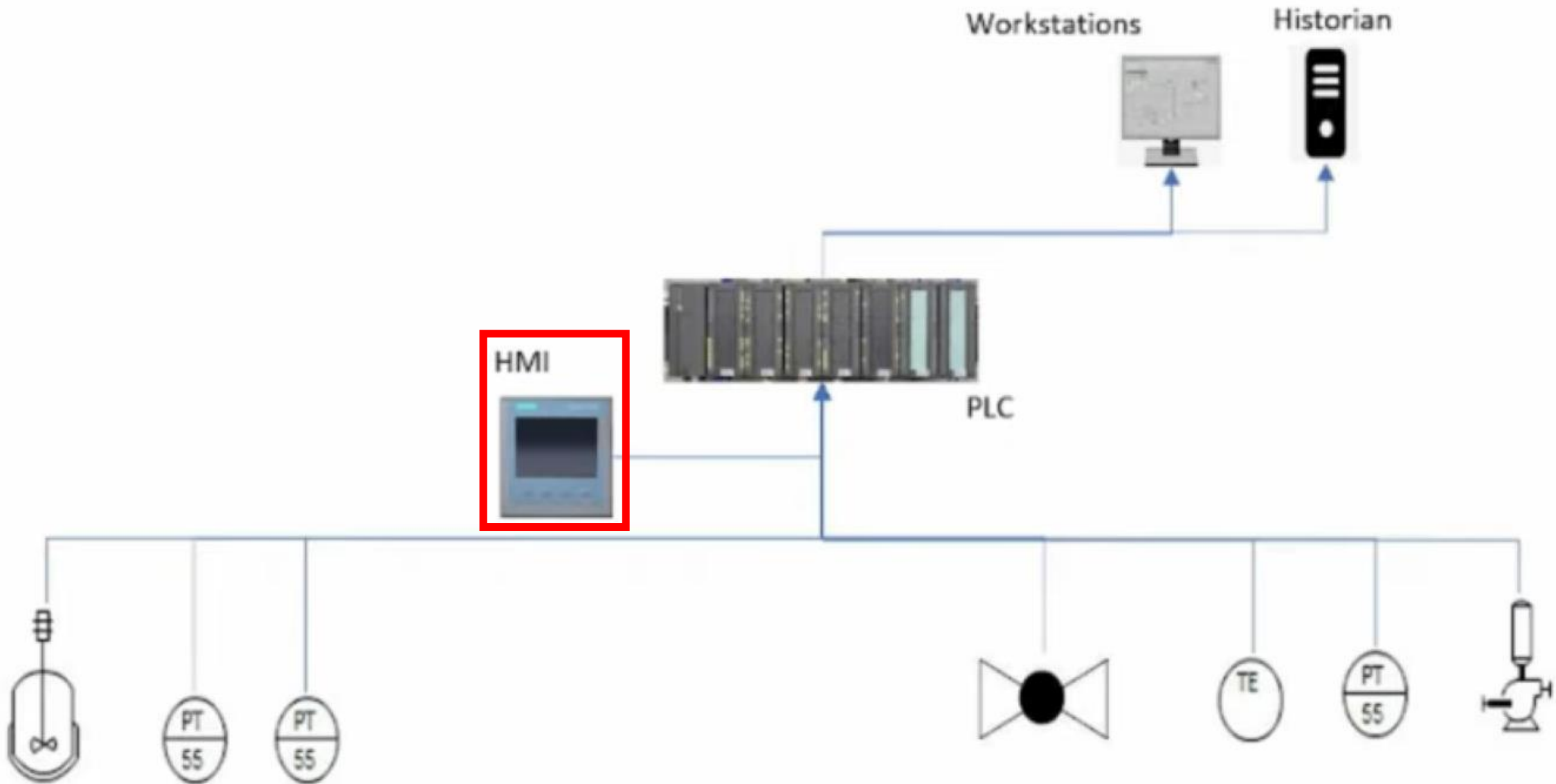

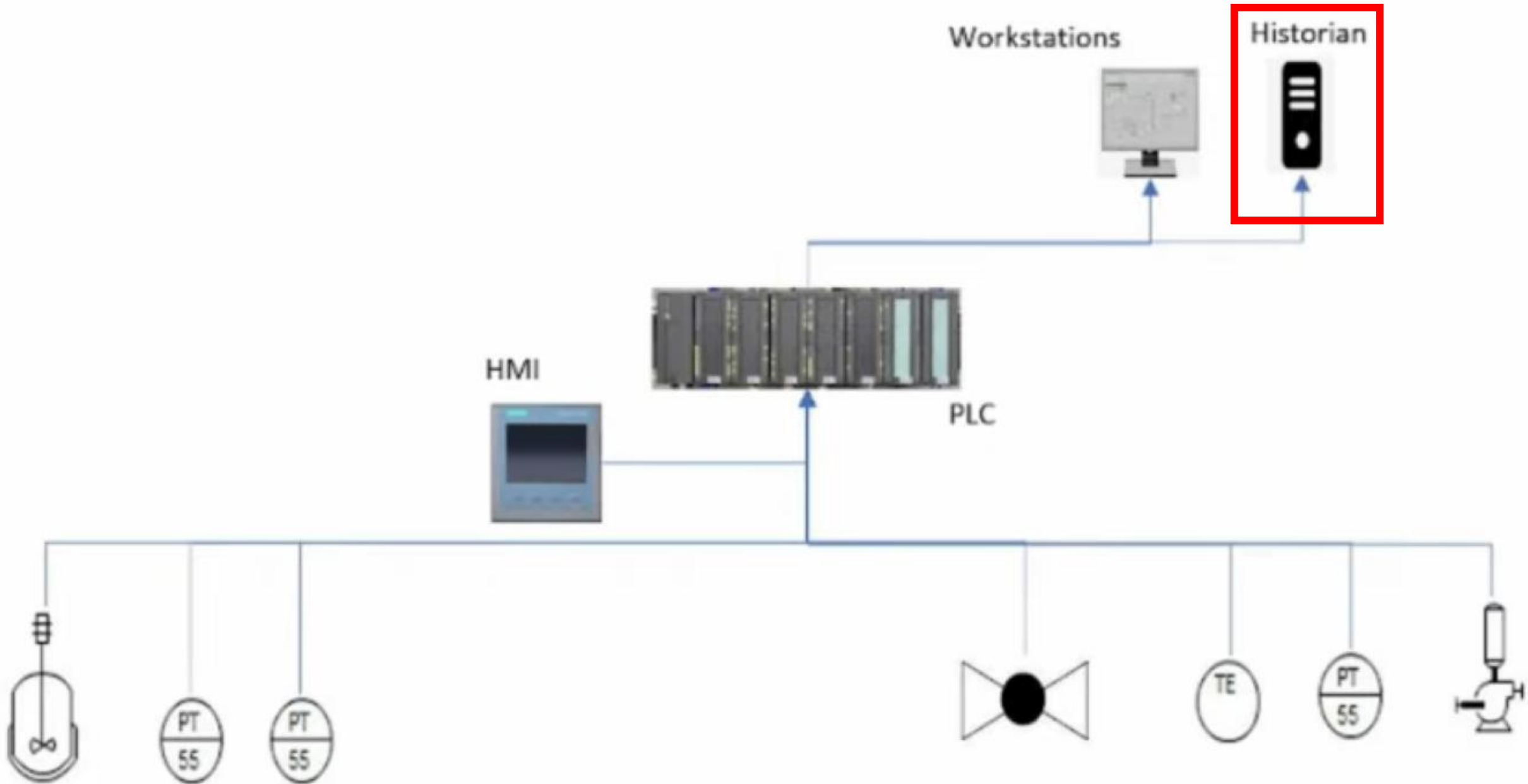

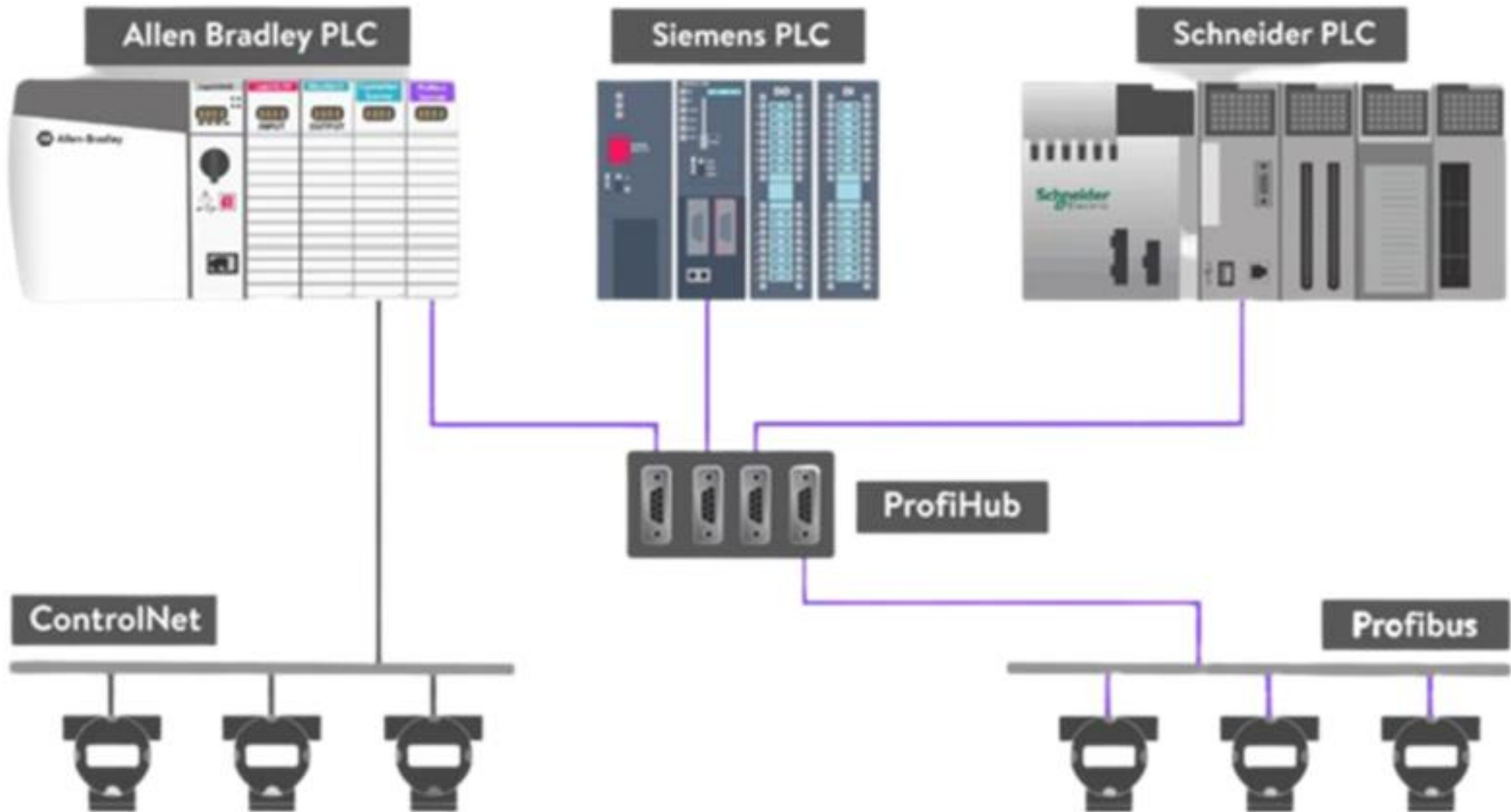

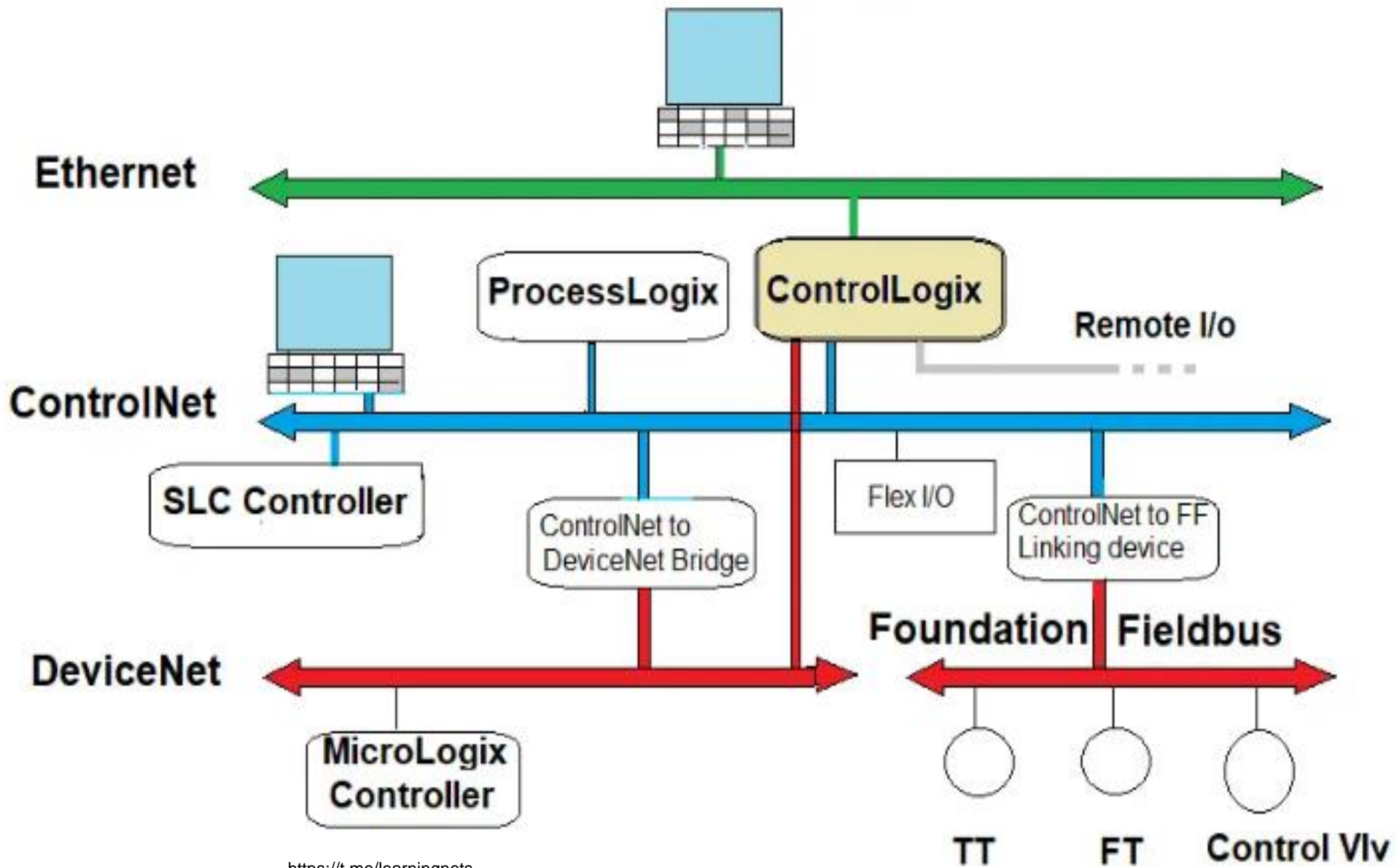

ControlNet

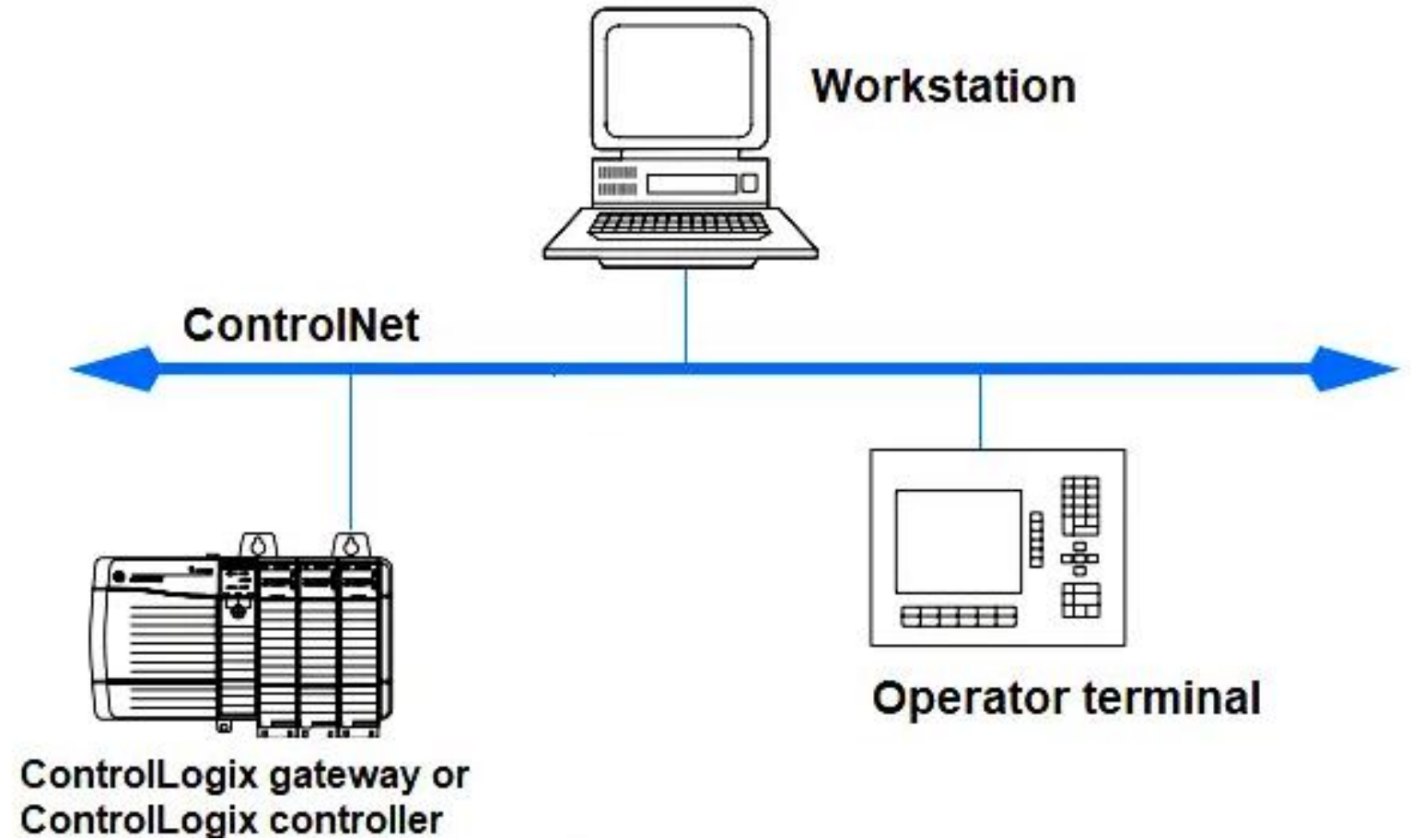

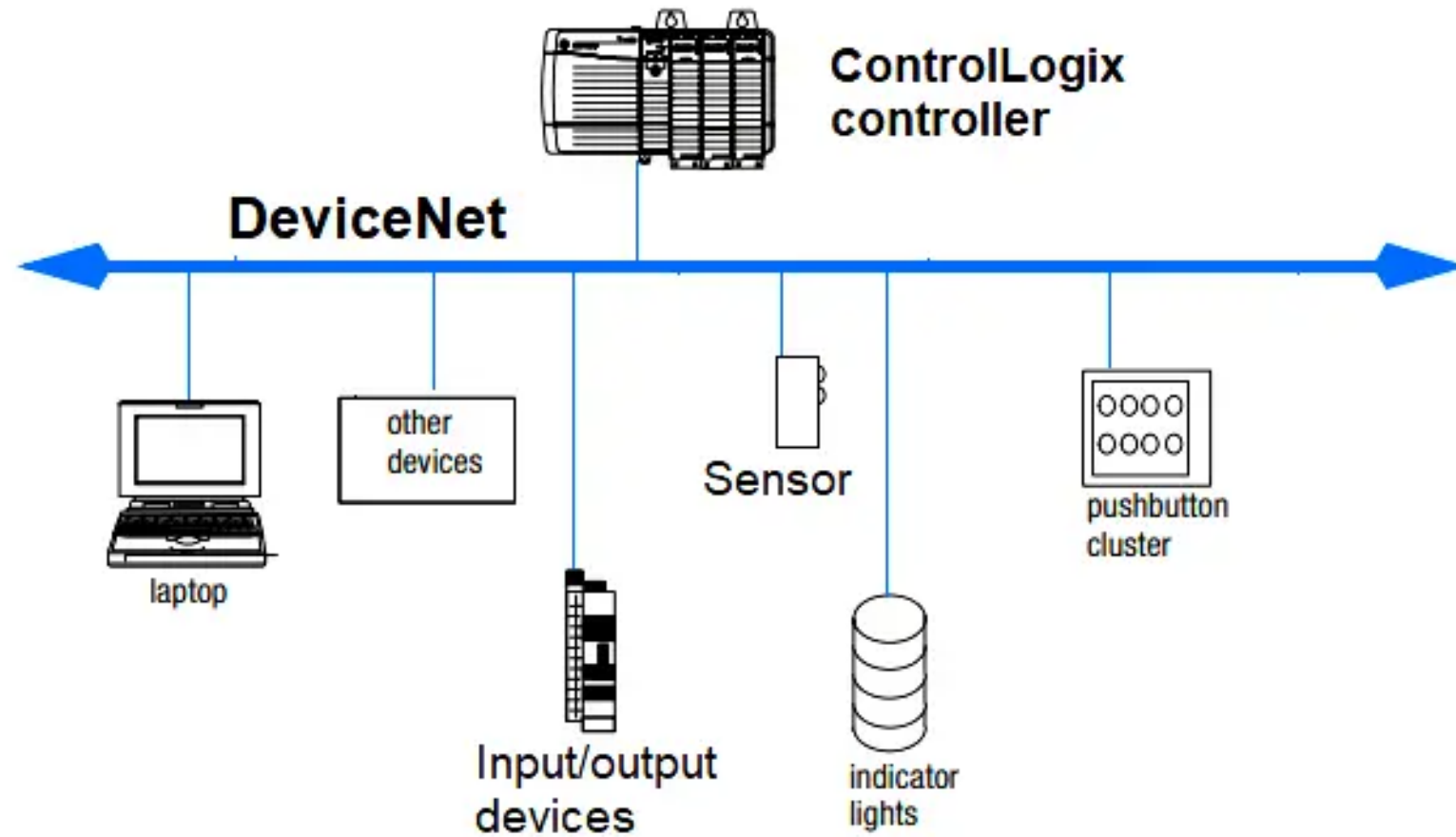

DeviceNet

Architecture of Allen Bradley PLC

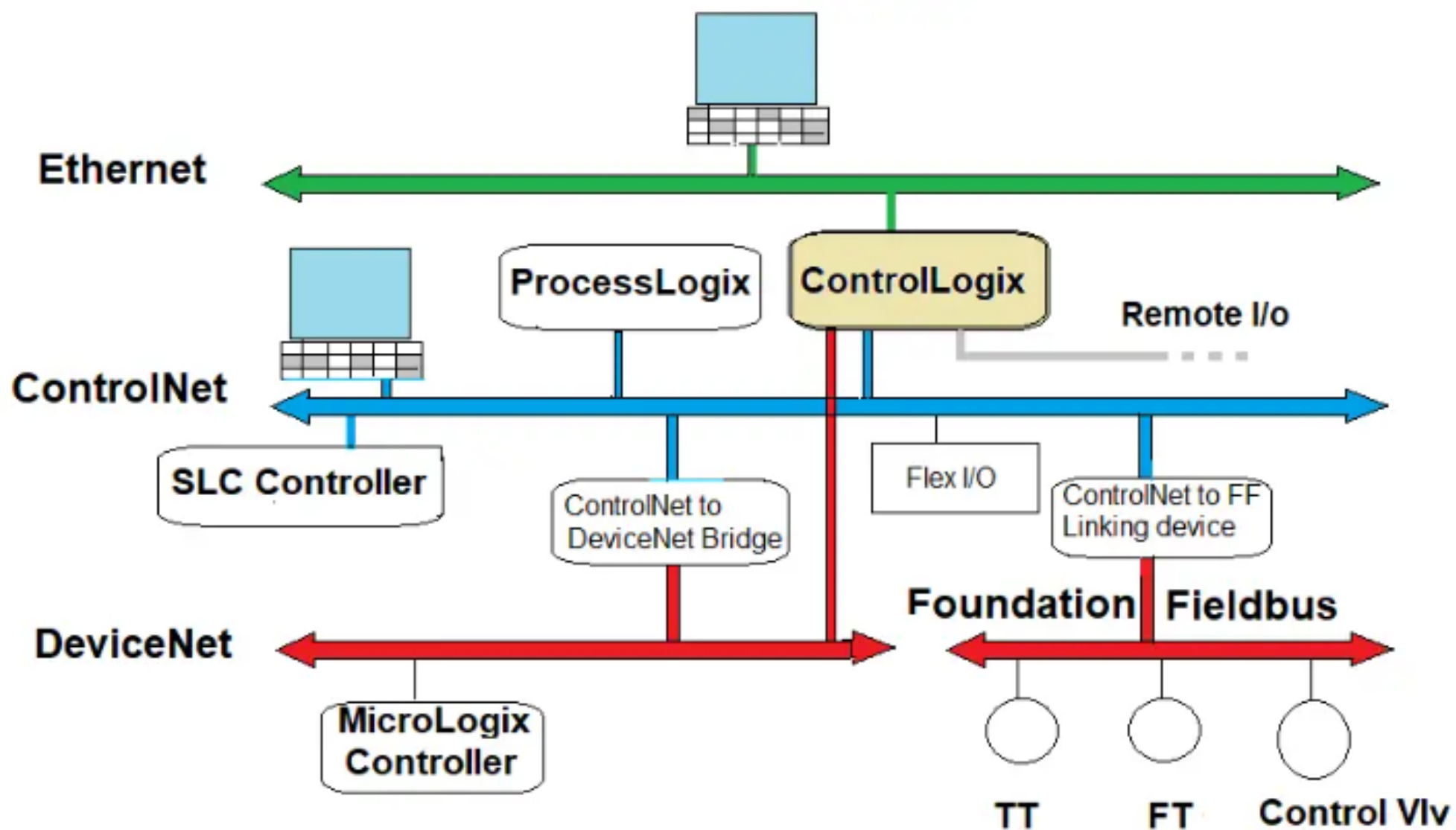

Ethernet Network

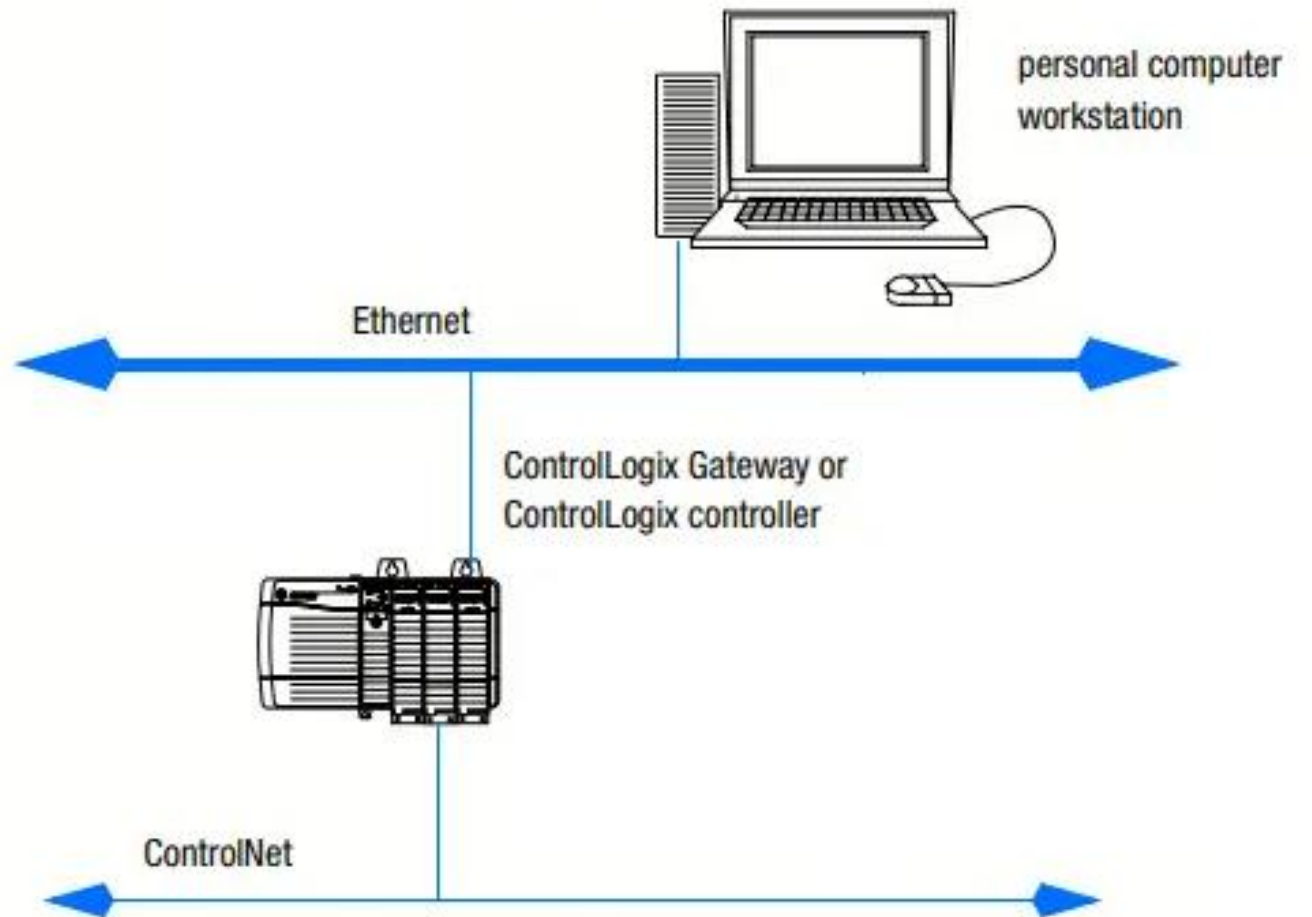

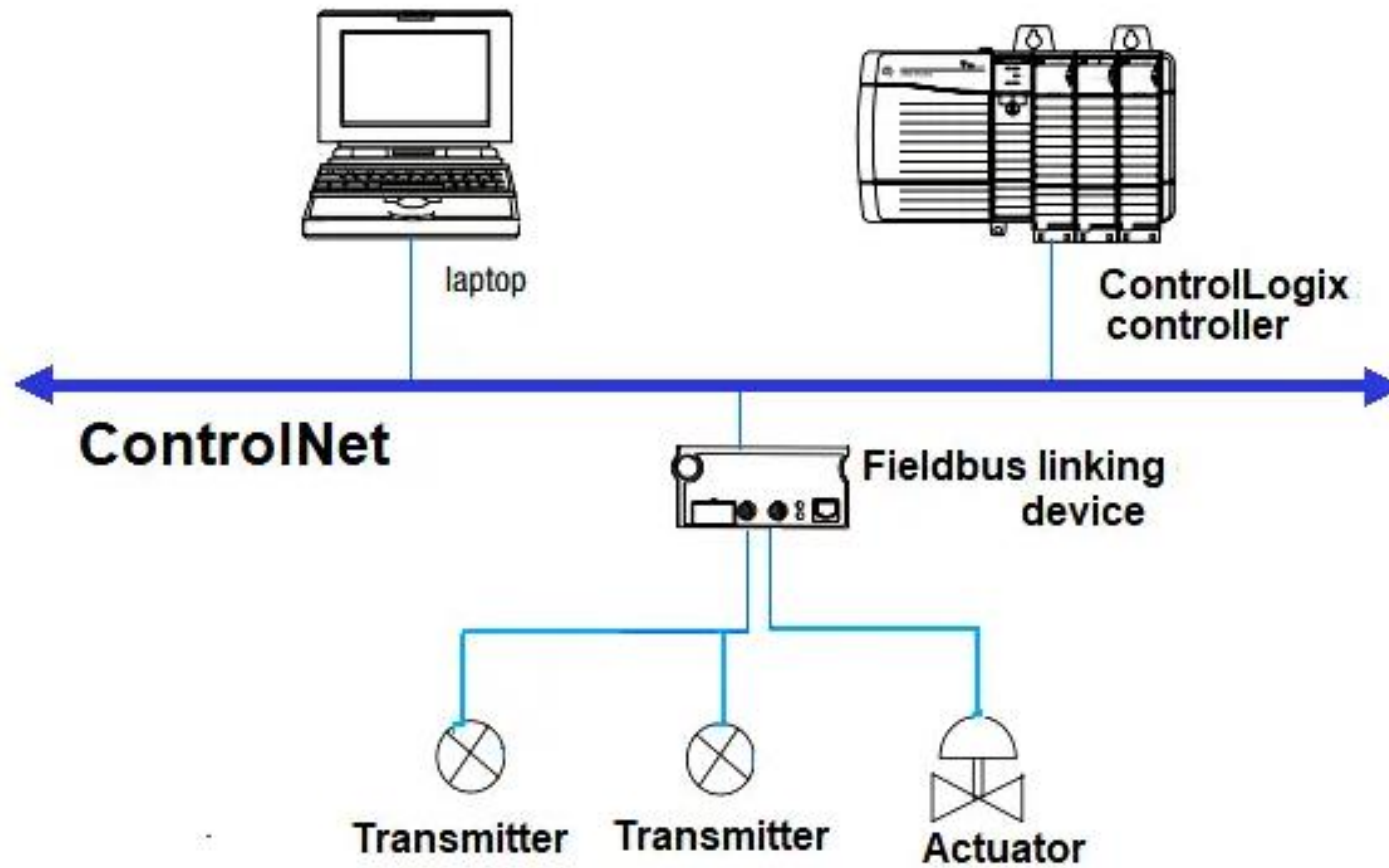

Fieldbus Network

ControlNet



EtherCAT  



Communication Networks

Wrap Up

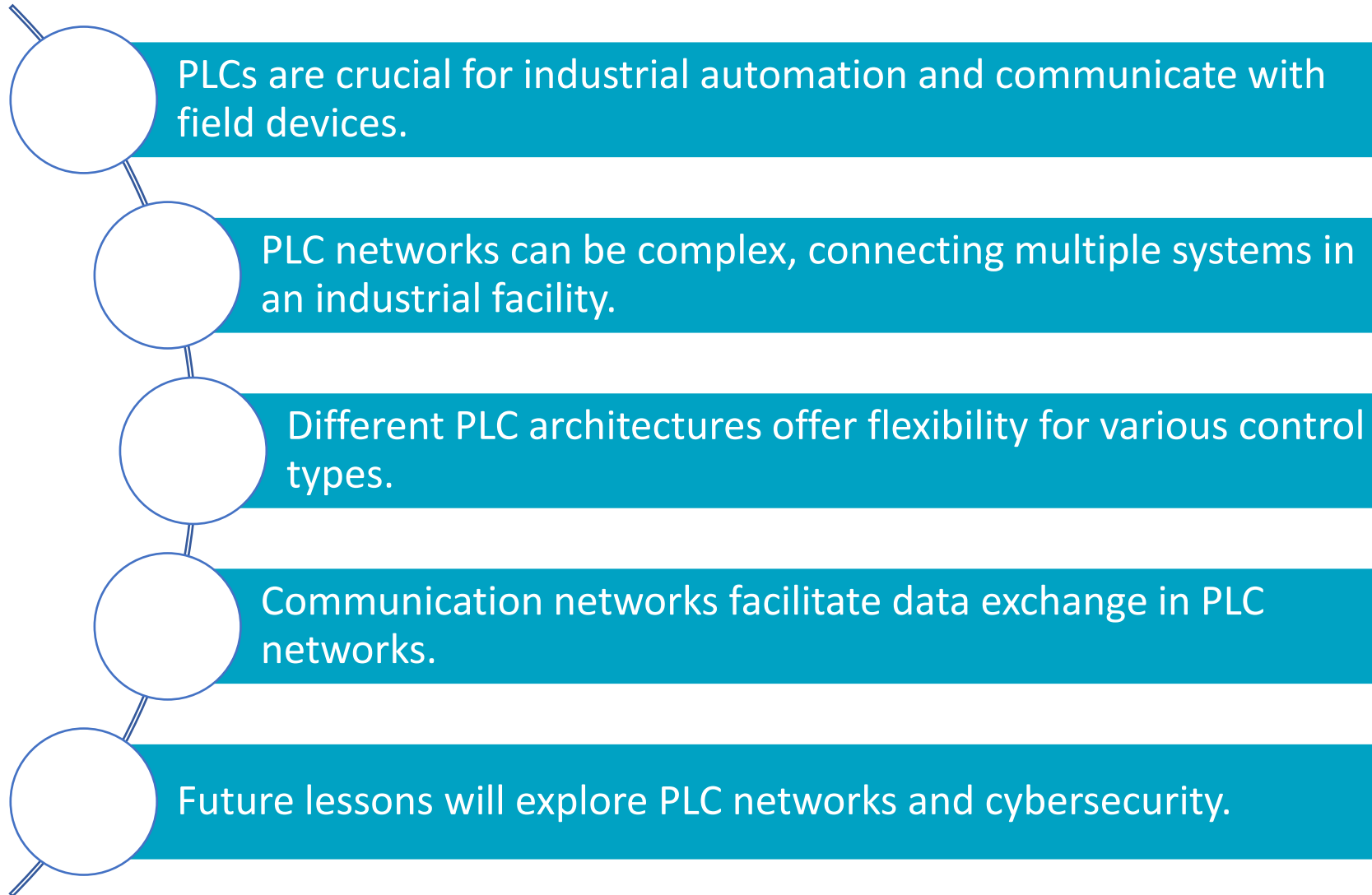



<https://t.me/learningnets>